



P.O. Box 787
Iron Mountain, MI 49801
United States

Owner's Manual

SK-R Skid Steer Box Plow

Part No. BXP16408—Serial No. 400000000 and Up

Part No. BXP16410—Serial No. 400000000 and Up

Part No. BXP16420—Serial No. 400000000 and Up

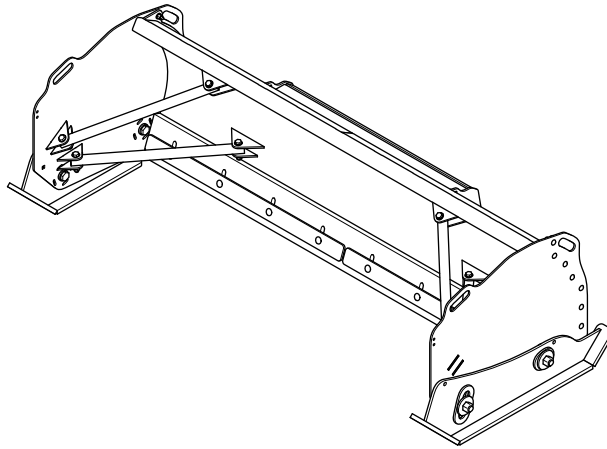

This product complies with all relevant European directives; for details, please see the separate product specific Declaration of Conformity (DOC) sheet.

BOSS Products limited consumer warranty and BOSS Products commercial warranty policies are located at www.bossplov.com.

Patents Pending.

Introduction

Read this information carefully to learn how to operate and maintain your product properly and to avoid injury and product damage. You are responsible for operating the product properly and safely.

You may contact BOSS directly at www.bossplov.com for product and accessory information, help finding a dealer, or to register your product.

Whenever you need service, genuine BOSS parts, or additional information, contact an Authorized BOSS Dealer or BOSS Technical Service (1-800-286-4155) and have the model and serial numbers of your product ready. **Figure 1** identifies the location of the model and serial numbers on the product. Write the numbers in the space provided.

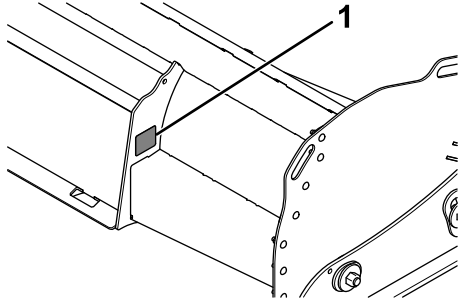

Figure 1

g250308

1. Serial number location

Date Purchased	_____
Model No.	_____
Serial No.	_____
Blade Crate Serial No.	_____

This manual identifies potential hazards and has safety messages identified by the safety-alert symbol (**Figure 2**), which signals a hazard that may cause

serious injury or death if you do not follow the recommended precautions.



Figure 2

g000502

1. Safety-alert symbol

This manual uses 2 words to highlight information. **Important** calls attention to special mechanical information and **Note** emphasizes general information worthy of special attention.

Contents

Safety	3
Preparation.....	3
Operation.....	3
Safety and Instructional Decals	4
Setup	5
Attaching the Plow Wings	5
Mounting the Plow	5
Product Overview	6
Specifications	6
Operation	7
Mounting the Plow	7
Removing the Plow.....	7
Operating Tips	7
Maintenance	8
Recommended Maintenance Schedule(s)	8
.....	8
Storage	8
Storing the Plow	8
Removing the Plow from Storage.....	8

Safety

Improper use or maintenance by the operator or owner can result in injury. To reduce the potential for injury, comply with these safety instructions and always pay attention to the safety-alert symbol , which means: **Caution, Warning, or Danger**—personal safety instruction. Failure to comply with the instruction may result in personal injury or death.

Preparation

- Read the *Owner's Manual* before operating or servicing the plow.
- Always follow the skid steer manufacturer's recommendations relating to system installation.
- Ensure that only trained personnel installs and performs maintenance on the equipment and hydraulic components.
- Always wear appropriate personal protective equipment when loading, unloading, and servicing the plow including hand and skin protection. Wear substantial, slip-resistant footwear, cold-weather clothing, hard hat, safety glasses, and respiratory protection.

Operation

- Use a 907 kg (1 ton) minimum lifting device to move heavy plow components.
- Never put any part of your body between the plow and the vehicle.
- When transporting the plow, ensure that it is properly secured. Instructions are available at www.bossplov.com.
- When transporting the vehicle, position the plow so as not to block your vision or the plow headlights.
- Do not change the blade position when traveling.
- Do not exceed 16 km/h (10 mph) while plowing.
- Always lower the blade when the vehicle is not in use.
- Safety data sheets (SDS) are available at www.bossplov.com.
- Do not operate the machine while ill, tired, or under the influence of alcohol or drugs.
- Always follow the manufacturer's recommendations for proper parking procedures.
- Always wear your seatbelt and/or lap bar while operating the vehicle.

- Overloading the plow could result in an accident or damage. Never exceed the rated operating capacity for the vehicle.
- Turn the vehicle and plow off before filling, servicing, or cleaning it.
- Do not operate the plow within 7.6 m (25 ft) of bystanders.
- Do not climb into or ride on the plow.
- Keep your hands, feet, and clothing away from moving parts and mounting points.

Safety and Instructional Decals



Safety decals and instructions are easily visible to the operator and are located near any area of potential danger. Replace any decal that is damaged or missing.



BXP16977

decalsxp16977

1. Warning—read the *Owner's Manual*.
2. Warning—all operators should be trained before operating the machine.
3. Warning—wear your seatbelt.
4. Crushing hazard—do not stand between the plow and vehicle during maintenance.
5. Separation hazard—ensure that the plow is securely attached to the vehicle.
6. Warning—do not block your vision with the plow.
7. Warning—do not exceed 16 km/h (10 mph) when plowing.
8. Warning—lower the plow when the vehicle is not in use.

Setup

Determine the left and right sides of the machine from the normal operating position.

Attaching the Plow Wings

1. On the left side of the plow blade, loosely attach the left wing using 7 carriage bolts (1/2 inch), washers (1/2 inch), and locknuts (1/2 inch) as shown in [Figure 3](#).

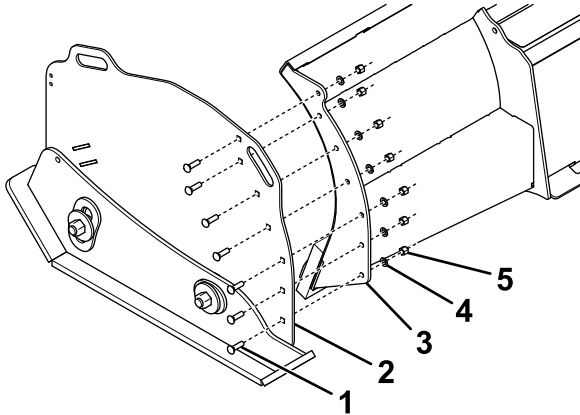

Figure 3

g250305

- | | |
|-----------------------------|-----------------------|
| 1. Carriage bolt (1/2 inch) | 4. Washer (1/2 inch) |
| 2. Wing | 5. Locknut (1/2 inch) |
| 3. Plow blade | |

2. Repeat step 1 on the right side of the plow.
3. On the left side of the plow, place a brace tube between the lower tabs on the plow blade and wing, and loosely secure it with 2 hex-head bolts (5/8 inch), 4 washers (5/8 inch), and 2 locknuts (5/8 inch) as shown in [Figure 4](#).

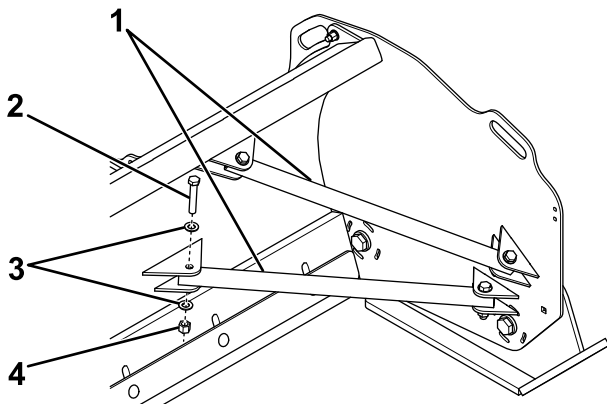

Figure 4

g250306

- | | |
|-----------------------------|-----------------------|
| 1. Brace tube | 3. Washer (5/8 inch) |
| 2. Hex-head bolt (5/8 inch) | 4. Locknut (5/8 inch) |

4. Place another brace tube between the upper tabs on the plow blade and wing, and loosely

secure it with 2 hex-head bolts (5/8 inch), 4 washers (5/8 inch), and 2 locknuts (5/8 inch) as shown in [Figure 4](#).

5. Repeat steps 3 and 4 on the right side of the plow.
6. Torque the fasteners to the following specifications:
 - Hex-head bolts (5/8 inch) to 153 N·m (113 ft-lb)
 - Carriage bolts (1/2 inch) to 76 N·m (56 ft-lb)

Mounting the Plow

Mount the plow; refer to [Mounting the Plow](#) (page 7).

Product Overview

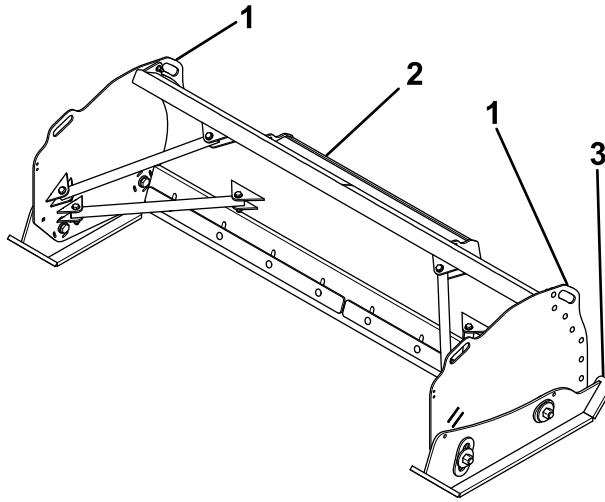

Figure 5

g250307

- 1. Lift point
- 2. Attachment plate
- 3. Wing shoe

Specifications

Note: Specifications and design are subject to change without notice.

Plow	8 ft Plow	10 ft Plow
Blade width	2.43 m (96 inches)	3 m (120 inches)
Blade height	76 cm (30 inches)	76 cm (30 inches)
Weight	251 kg (555 lb without wings) 440 kg (970 lb with wings)	301 kg (664 lb without wings) 490 kg (1,080 lb with wings)

Operation

Note: Determine the left and right sides of the machine from the normal operating position.

Mounting the Plow

1. Drive the skid steer forward into the back of the plow frame (Figure 6).

Important: Refer to your skid steer *Operator's Manual* for safety and operating procedures.

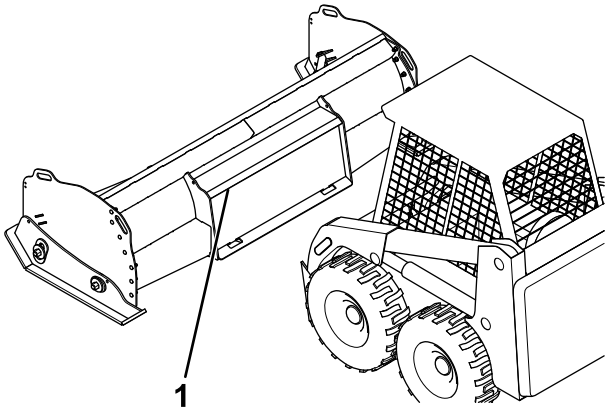

g250304

Figure 6

1. Top lip

-
2. Slide the top of the skid-steer attachment plate under the top lip of the plow attachment plate.
 3. Adjust the attachment plate position until the 2 are flush against each other.
 4. Before locking the plow frame onto the skid-steer attachment plate, lower the plow, shut off the engine, engage the parking brake, and remove the key.

Note: For vehicles equipped with hydraulic locking attachments, leave the machine running.

Removing the Plow

1. Park the skid steer on a level surface, lower the plow, shut off the engine, engage the parking brake, and remove the key.

Important: Refer to your skid steer *Operator's Manual* for safety and operating procedures.

Note: For vehicles equipped with hydraulic locking attachments, leave the machine running.

2. Unlock the plow frame from the skid-steer attachment plate.
3. Slowly back the skid steer away from the plow.

Operating Tips

- Become familiar with the area you are plowing; hidden obstructions such as curbs and pipes can damage your plow or machine.
- Do not let snow accumulate; always plow with the storm.
- Lower the plow when not in use to prevent possible injury.
- Always plow at a safe speed in case you hit hidden obstructions.
- When transporting the machine, do not block your vision with the plow.
- Do not change the plow position while plowing.

Maintenance

⚠ WARNING

Failure to properly maintain the machine could result in premature failure of machine systems causing possible harm to you or bystanders.

Keep the machine well maintained and in good working order as indicated in these instructions.

⚠ CAUTION

If you leave the key in the switch, someone could accidentally start the engine and seriously injure you or other bystanders.

Remove the key from the switch before you perform any maintenance.

Note: Determine the left and right sides of the machine from the normal operating position.

Recommended Maintenance Schedule(s)

Maintenance Service Interval	Maintenance Procedure
Before each use or daily	<ul style="list-style-type: none">• Check the torque of all fasteners, pins, retainers, nuts, and bolts.• Check the cutting edge.• Check the plow wing shoes.• Check the attachment system.

Storage

Storing the Plow

1. Drive the snowplow to your storage location and remove the plow; refer to [Removing the Plow \(page 7\)](#).
2. Lightly sand and use touch-up paint on painted areas that are scratched, chipped, or rusted.

Removing the Plow from Storage

1. Check the plow for cracked welds.
2. Check the torque of all fasteners, pins, retainers, nuts, and bolts; tighten as necessary.
3. Check the cutting edge for wear.
4. Check the wing shoes for wear.
5. Lightly sand and use touch-up paint on painted areas that are scratched, chipped, or rusted.
6. Attach the plow to the vehicle; refer to [Mounting the Plow \(page 7\)](#).