

BOSS Products limited consumer warranty and BOSS Products commercial warranty policies are located at www.BOSSPlow.com.

Patent www.ttcopats.com.

Installation

Preparing the Machine

1. Park the machine on a level surface.
2. Lower the attachment.
3. Move the motion-control levers to the NEUTRAL position.
4. Wait for all moving parts to stop.
5. Engage the parking brake.
6. Remove the key.
7. Allow machine components to cool.

Removing the Cover, Top Screen, and Bag Splitter

1. Release the 2 cover latches on the cover.

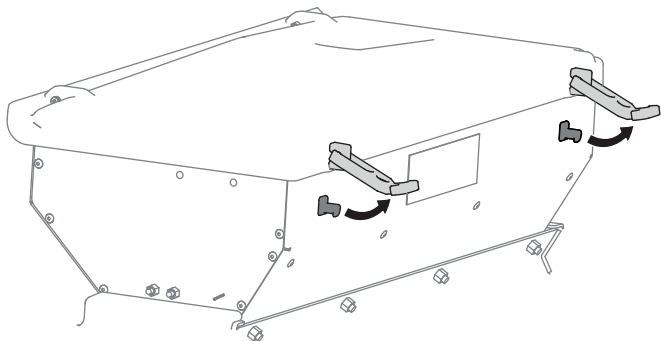

Figure 1

g497940

2. Remove and retain the 2 bolts and 2 nuts securing the hinges of the cover to the machine. Remove the cover from the machine.

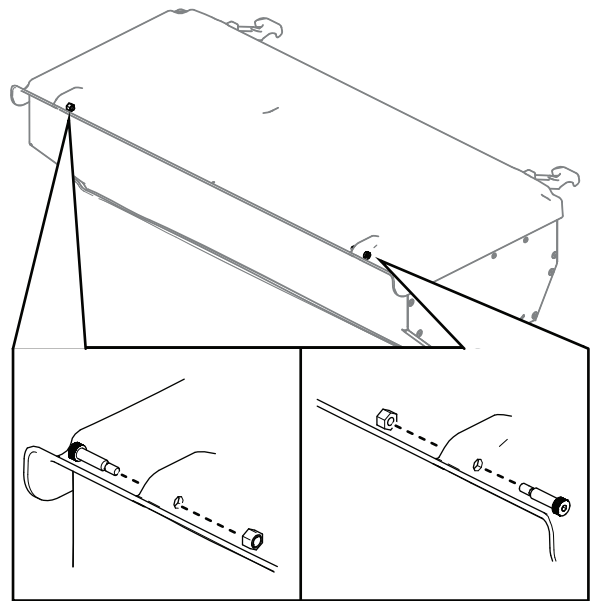

Figure 2

g497952

3. On the underside of the cover, remove and retain the 2 screws and 2 washers securing each latch to the cover. Retain the 2 latches.

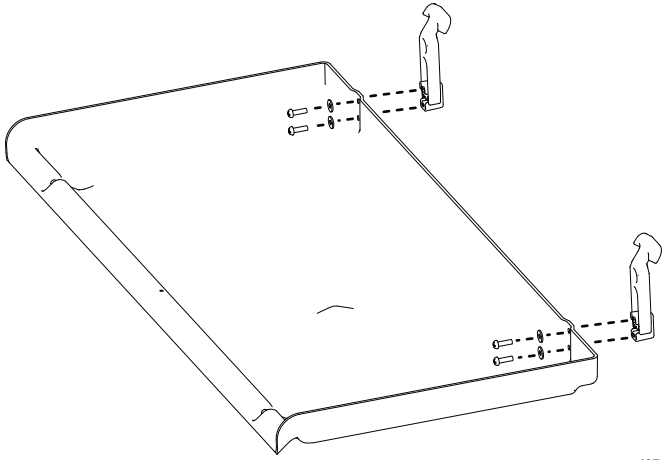

Figure 3

g497953

5. Remove the top screen from the machine by removing the 4 bolts.

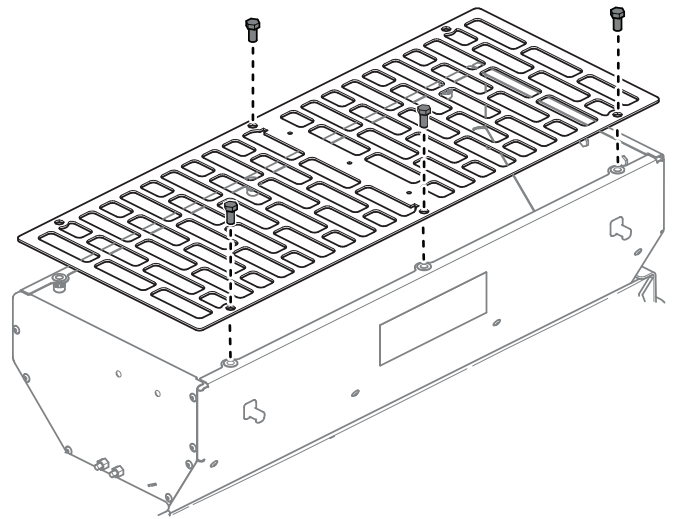

Figure 5

g497956

4. Remove and retain the top-screen hinges by removing the 2 bolts.

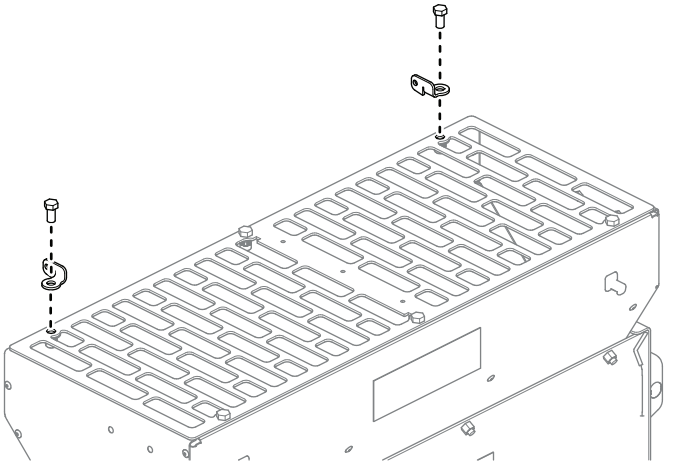

Figure 4

g497955

Installing the Kit

1. Install the spill guard, top screen, top-screen hinges, and bolts as shown below.

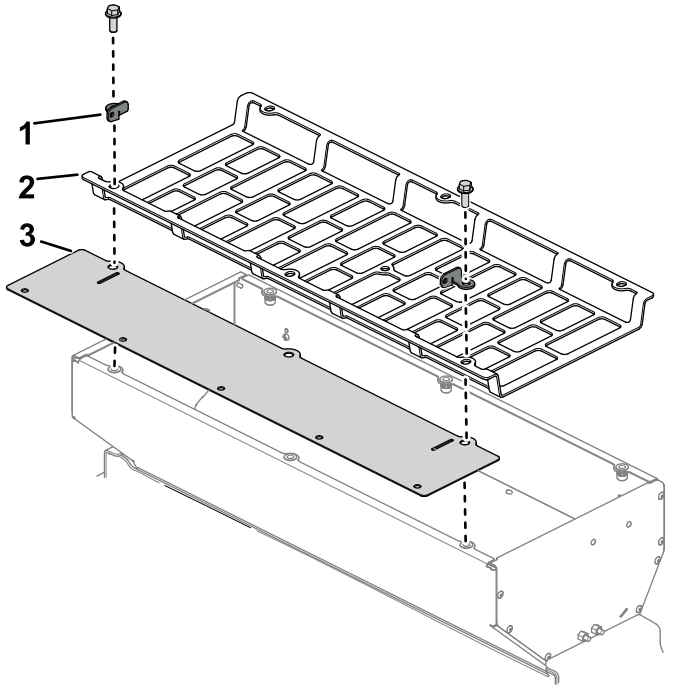

Figure 6

g497957

1. Top-screen hinge
2. Top screen
3. Spill guard

2. Use the 3 bolts and 1 nut to secure the bag splitter to the top screen.

Note: The nut secures the middle of the bag splitter to the top screen.

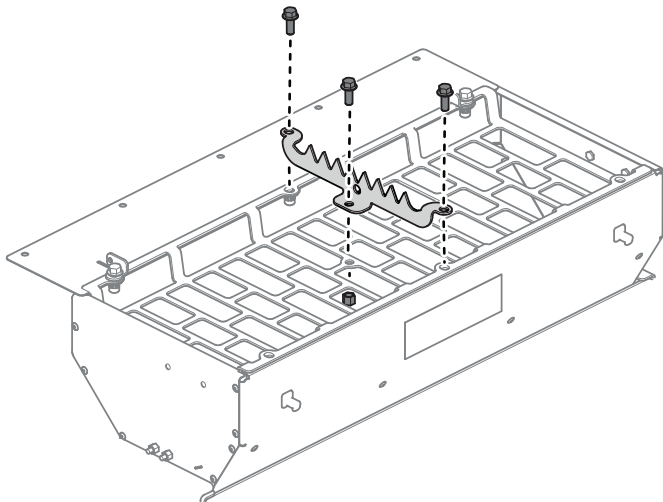

Figure 7

g497960

3. Install the remaining 2 bolts securing the top screen to the machine.

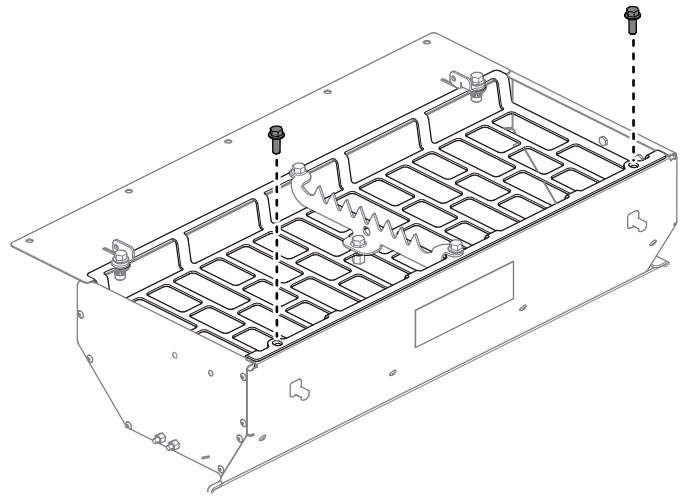

Figure 8

g497961

4. Install the 2 latches to the cover with the 2 screws and 2 washers.

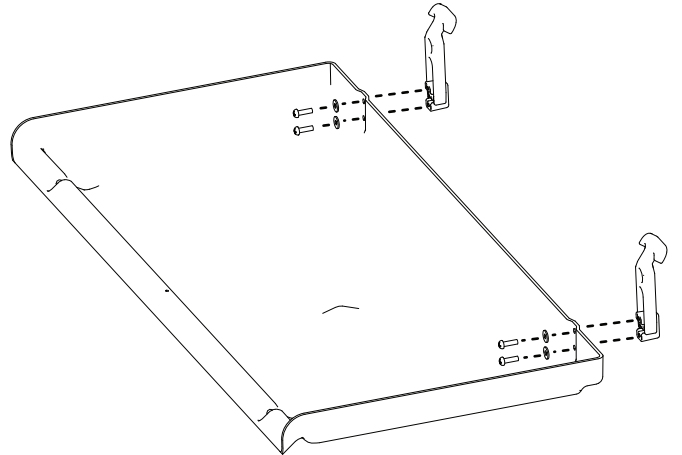

Figure 9

g497953

5. Fold the spill guard over the top-screen hinges. Place the cover over the hinges and secure it with the retained bolts and nuts.

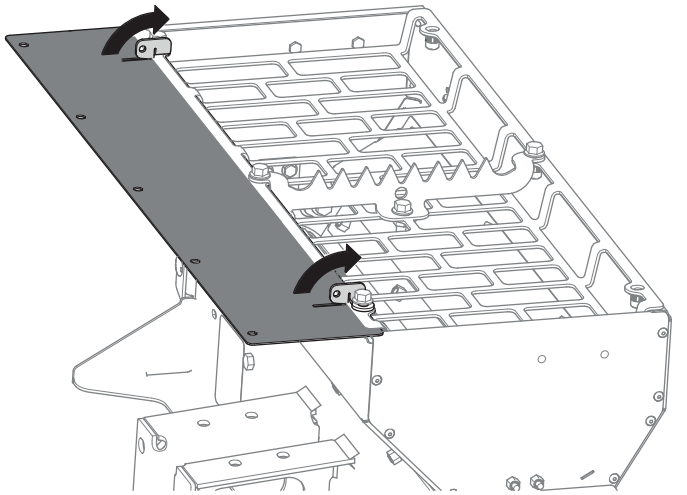

Figure 10

g497997

6. Secure the spill guard to the cover with the 5 bolts, 10 washers, and 5 nuts.

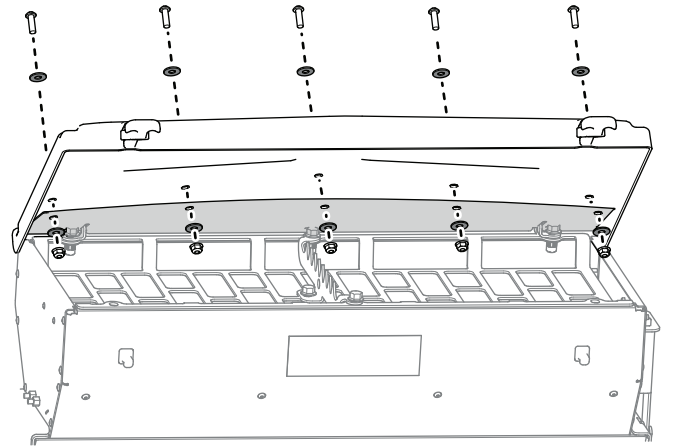

Figure 12

g497927

7. Secure the 2 cover latches to the machine.

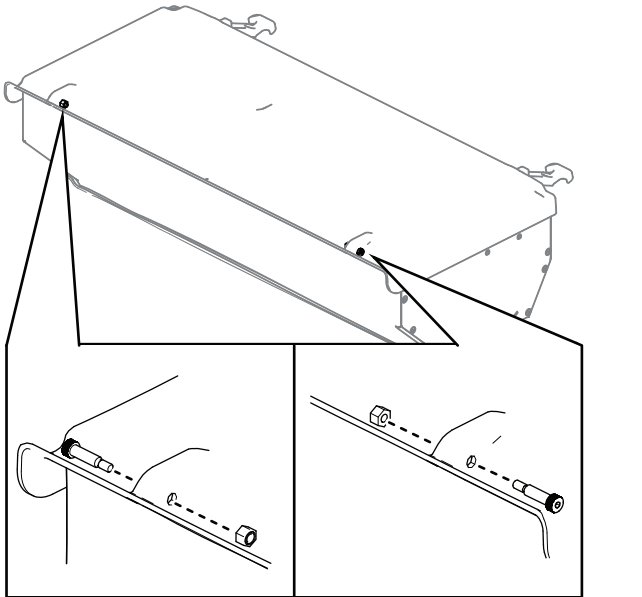

Figure 11

g497952