

Safety

- Always follow the vehicle manufacturer's recommendations relating to snowplow installation. For recommended vehicle models, refer to the *BOSS Snowplow Application Chart and Selection Guide*.
- Many newer trucks are equipped with air bags. **Never** disable, remove, or relocate any sensors or other components related to the operation of the air bags.
- To comply with federal regulations and to assure a safe vehicle, do not exceed the front gross-axle-weight rating (FGAWR), rear gross-axle-weight rating (RGAWR), and the gross-vehicle-weight rating (GVWR) at any time.
- Due to the variety of equipment that you can install on the vehicle, do not exceed the front gross-axle-weight rating (FGAWR), rear gross-axle-weight rating (RGAWR), and the gross-vehicle-weight rating (GVWR) at any time. This may require weighing the vehicle and adding ballast as necessary. It may also limit the payload capacity of the vehicle.

Installation

Determine the left and right sides of the machine from the normal operating position.

1. Park the machine on a level surface, shut off the engine, wait for all moving parts to stop, engage the parking brake, and remove the key.
2. Remove the front bumper and tow hook from the vehicle.
3. Secure the side plates to the vehicle frame using 4 bolts (16 x 80 mm) and 4 nuts (16 mm).

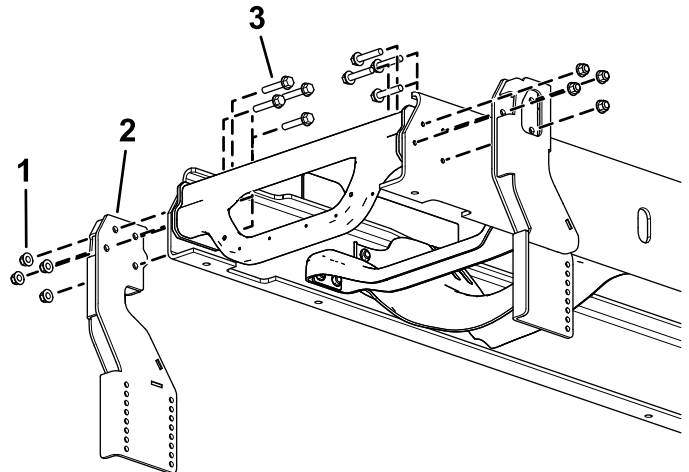

g254274

Figure 1

- | | |
|----------------|----------------------|
| 1. Nut (16 mm) | 3. Bolt (16 x 80 mm) |
| 2. Side plate | |

4. Position the pushbeam so that the distance from the ground to the center of the attachment pin holes on the pushbeam is 42 cm (16-1/2 inches).
5. Loosely secure the pushbeam assembly to the side plates using 16 bolts (1/2 x 2 inches) and 16 nuts (1/2 inch).

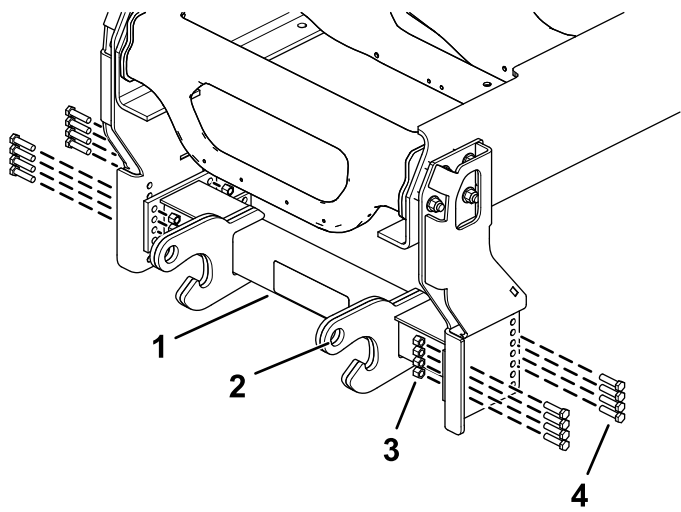

Figure 2

g254277

- | | |
|-----------------------------|-----------------------------------|
| 1. Pushbeam assembly | 3. Nut (1/2 inch) |
| 2. Center of the attachment | 4. Bolt (1/2 x 2 inches) pin hole |

6. Secure the angle brackets to the pushbeam assembly using 8 bolts (1/2 x 2 inches) and 8 nuts (1/2 inch).

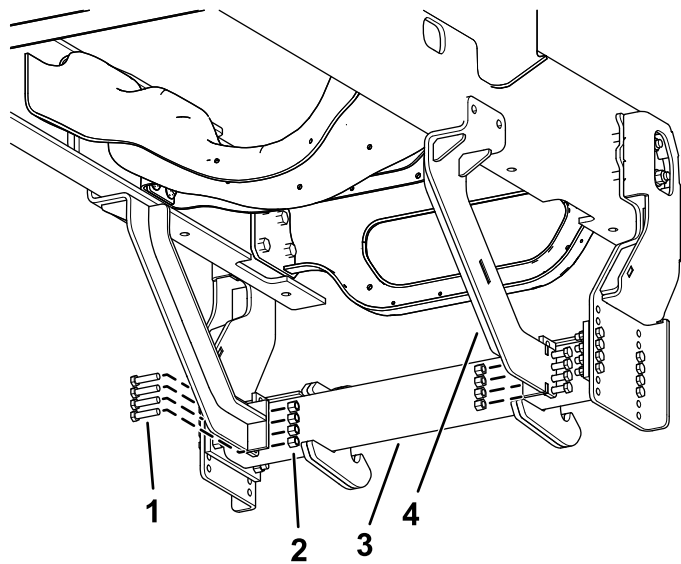

Figure 3

g254275

- | | |
|--------------------------|----------------------|
| 1. Bolt (1/2 x 2 inches) | 3. Pushbeam assembly |
| 2. Nut (1/2 inch) | 4. Angle bracket |

⚠ WARNING

Using a drill without wearing eye protection may allow debris to enter the eye, causing personal injury.

When drilling, always wear eye protection.

7. Using the angle bracket as a guide, drill out the 4 holes in the vehicle frame to 11/16 inches.

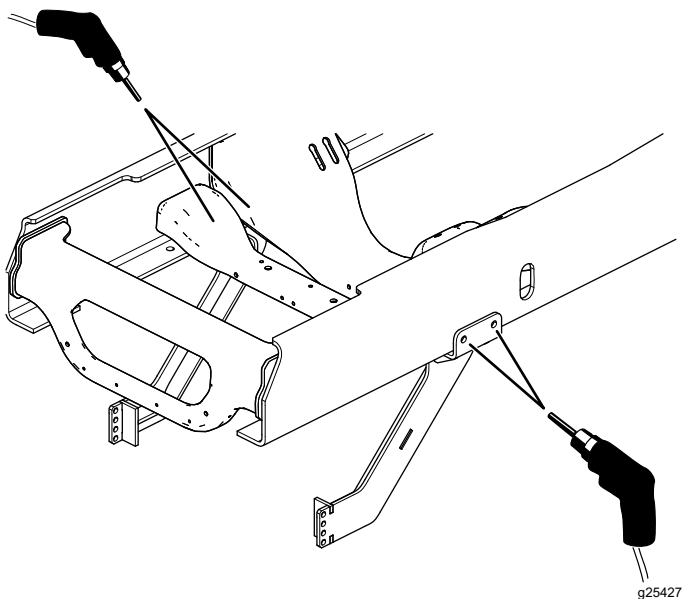

Figure 4

g254273

8. Secure the angle brackets to the vehicle frame using 4 bolts (5/8 x 2 inches), 4 washers, and 4 nuts (5/8 inch).

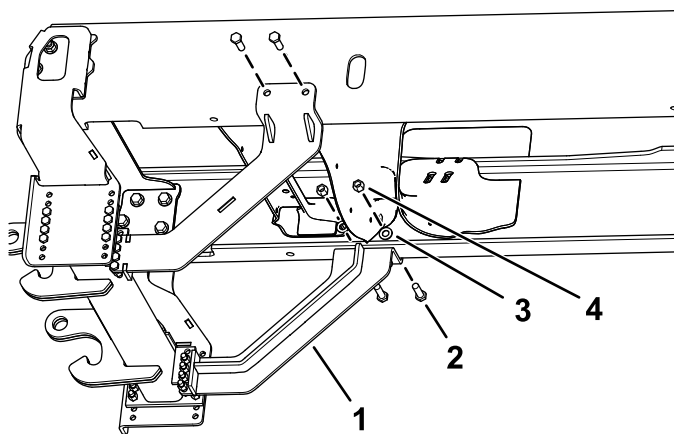

Figure 5

g254276

- | | |
|--------------------------|-------------------|
| 1. Angle bracket | 3. Washer |
| 2. Bolt (5/8 x 2 inches) | 4. Nut (5/8 inch) |

9. Torque all the fasteners to the following specifications:

- 16 mm bolts to 312 N·m (230 ft-lb)
- 1/2-inch bolts to 76 N·m (56 ft-lb)
- 5/8-inch bolts to 153 N·m (113 ft-lb)

10. Install the previously removed front bumper.

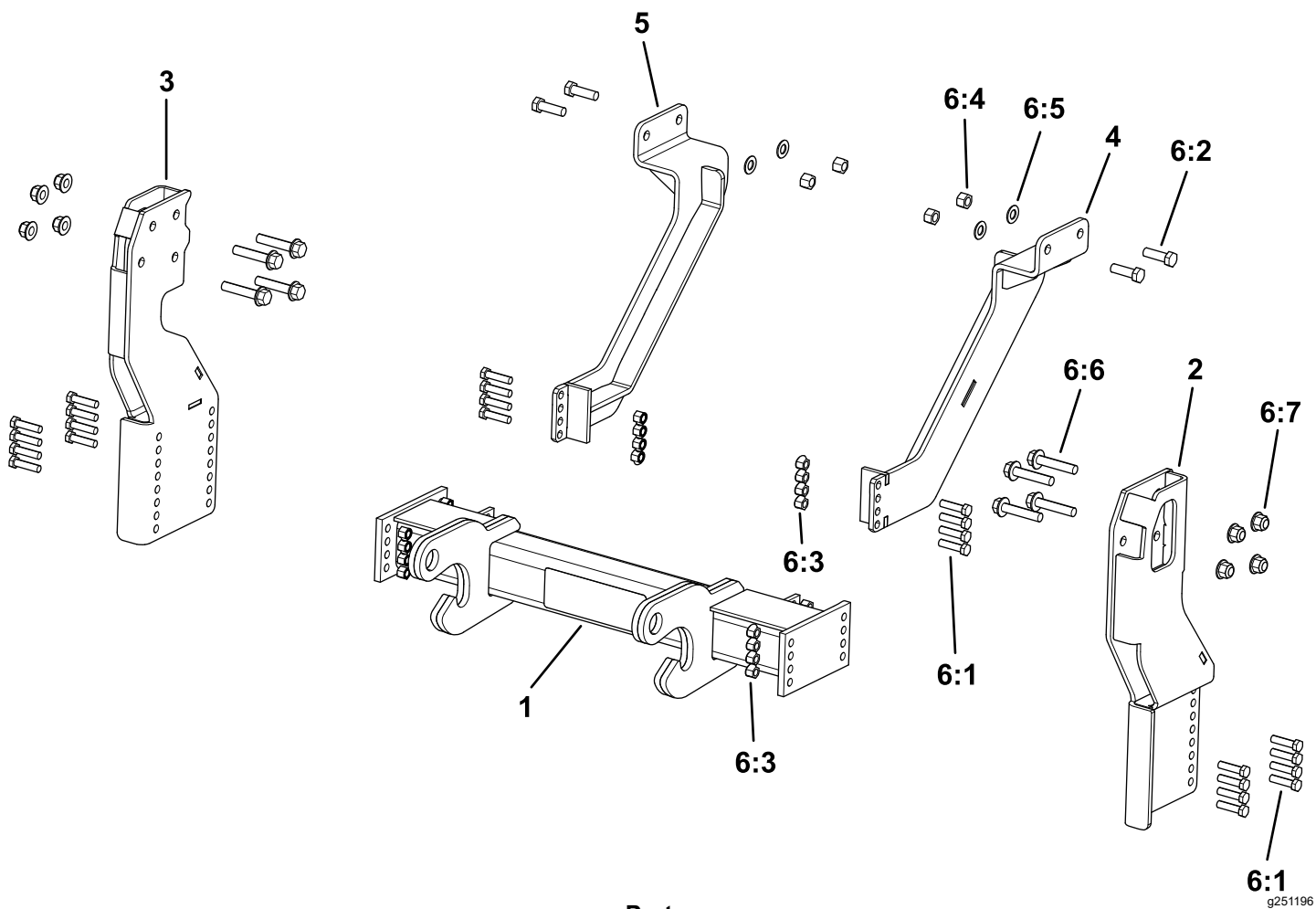

Parts

Ref.	Part Number	Qty.	Description	Ref.	Part Number	Qty.	Description
1	PBA10395-03	1	PUSHBEAM ASSEMBLY	6:1	HDW01755	24	1/2" – 13 X 2" HEX HEAD BOLT GR 5
2	PBA27640-03	1	PUSH BEAM SUPPORT PLATE DRIVER SIDE (LH)	6:2	HDW01731	4	5/8" – 11 X 2 HEX HEAD BOLT GR 5
3	PBA27650-03	1	PUSH BEAM SUPPORT PLATE PASSENGER SIDE (RH)	6:3	HDW01748	24	1/2" – 13 NYLOCK NUT
4	LTA27645-03	1	ANGLE BRACKET DRIVER SIDE (LH)	6:4	HDW01709	4	5/8" – 11 TOP NUT GRB
5	LTA27655-03	1	ANGLE BRACKET PASSENGER SIDE (RH)	6:5	HDW01726	4	5/8" FLAT WASHER HARDEN
6	HDW10409	1	FASTENER KIT	6:6	HDW10398	8	M16 X 80MM FLANGE HEAD BOLT, 10.9
				6:7	HDW10399	8	M16 FLANGE HEAD NYLOCK NUT, 10.9

BOSS
S N O W P L O W