

Installation Instructions

Safety

- Always follow the vehicle manufacturer's recommendations relating to system installation.
- Due to the variety of equipment that you can install using the undercarriage, ensure that the gross-vehicle-weight rating (GVWR) is not exceeded at any time. You may need to weigh the vehicle and add ballast or limit the payload of the vehicle to compensate.

Installation

Installing the Undercarriage

Determine the left and right sides of the machine from the normal operating position.

1. Park the machine on a level surface, shut off the engine, wait for all moving parts to stop, engage the parking brake, and remove the key.
2. On one side of the frame, remove 2 bolts and nuts where the side plates will be installed (Figure 1).

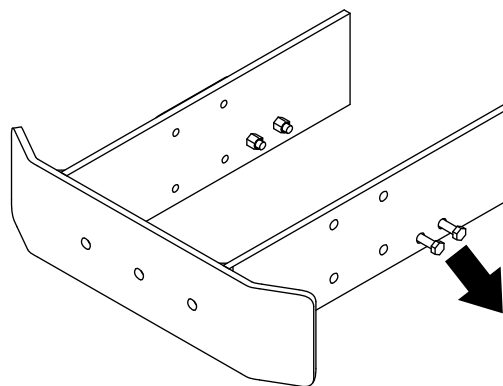

Figure 1

g259348

3. Install the side plates using 4 bolts and nuts, as shown in Figure 2.



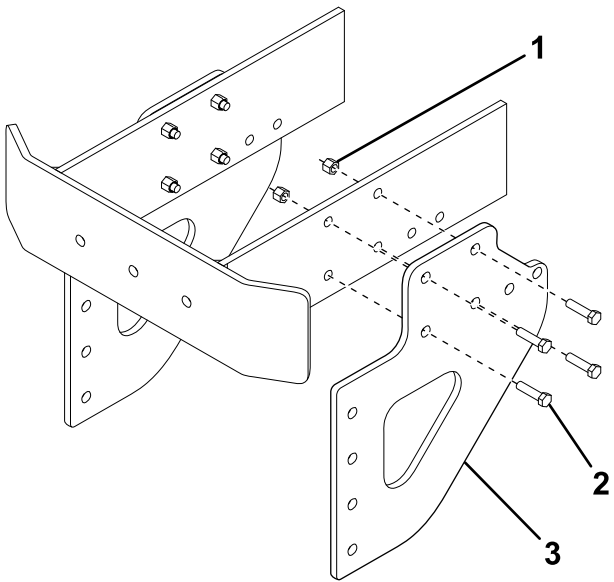

Figure 2

g216488

1. Nut (3/8 inch)
2. Bolt (3/8 inch)
3. Side plate

4. Install the 2 bolts and nuts previously removed, as shown in [Figure 3](#).

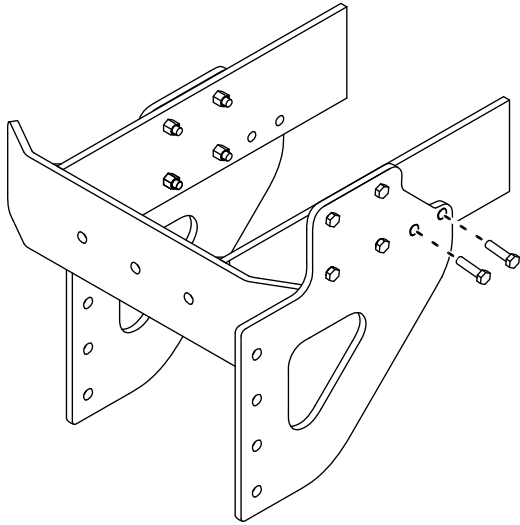

Figure 3

g259347

5. Repeat steps 2 to 4 on the other side of the frame.

6. Secure the front plate to the frame and side plates using 7 bolts (1/2 x 1-1/2 inches) and nuts ([Figure 4](#)).

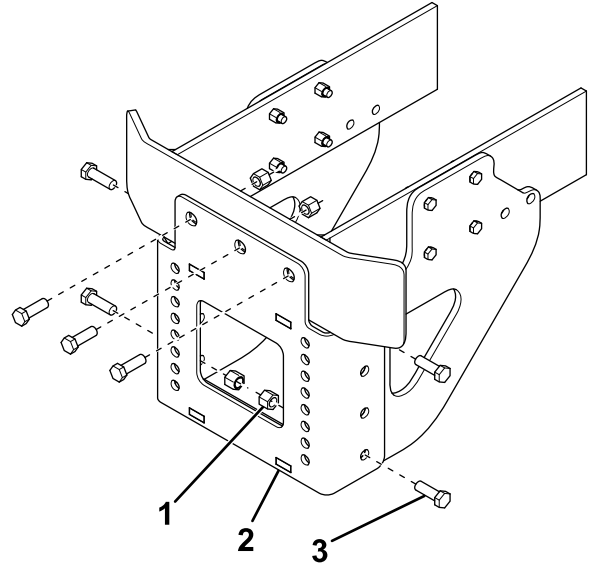

Figure 4

g216489

1. Nut (1/2 inch)
2. Front plate
3. Bolt (1/2 x 1-1/2 inches)

7. Secure the side gussets to the side plates using 4 bolts (1/2 x 2 inches) and 4 nuts ([Figure 5](#)).

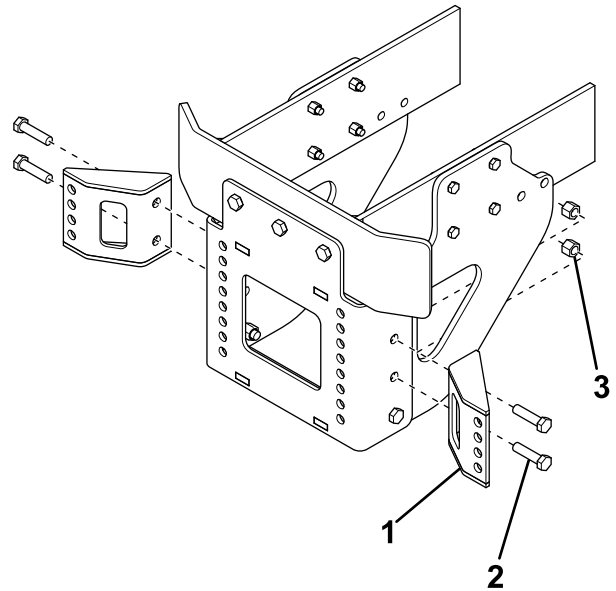

Figure 5

g216490

1. Side gusset
2. Bolt (1/2 x 2 inches)
3. Nut

8. Secure the pushbeam to the side gussets and front plate using 8 bolts (1/2 x 1-1/2 inches) and 8 nuts ([Figure 6](#)).

Note: Refer to your plow *Owner's Manual* for the appropriate pushbeam height.

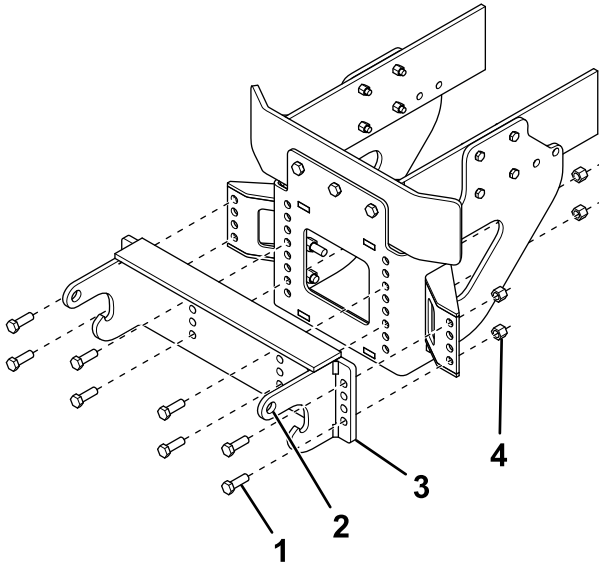

Figure 6

g216491

- | | |
|------------------------------|-------------------|
| 1. Bolt (1/2 x 1-1/2 inches) | 3. Pushbeam |
| 2. Coupler spring-pin hole | 4. Nut (1/2 inch) |
9. Torque all of the fasteners to the following specifications:
- 3/8 inch bolts to 31 N·m (23 ft-lb)
 - 1/2 inch bolts to 76 N·m (56 ft-lb)

Installing the Wire Harness

⚠ DANGER

Vehicle engines contain moving parts and can become extremely hot, capable of causing severe burns and serious bodily harm.

Shut off the engine and allow it to cool down before installing this kit.

⚠ DANGER

Vehicle batteries can cause dangerous electrical shocks that could lead to severe burns or death.

Disconnect the battery before installing this kit.

1. Discard the long power/ground cable and the headlight toggle switch included with the control kit.
2. Connect the partially stripped blue wire from the tractor light harness to the blue upfitter wire on the vehicle wire harness using the existing butt connector.
3. Connect the partially stripped red wire from the tractor light harness to the red upfitter wire on the vehicle wire harness using the existing butt connector.
4. Connect the black wire from the tractor light harness to the negative (-) battery terminal post.
5. Ensure that the vehicle firewall is clear of obstructions.
6. Drill a 3 cm (1-1/4 inches) diameter hole through the firewall on the driver side of the vehicle.

Note: The hole should be in an easily accessible area.

7. Insert the split rubber-grommet into the hole.
8. Pull the plow controller connector, black/red wire, 3 tractor light harness connectors, and 2 black wires into the vehicle cab through the hole in the firewall ([Figure 7](#)).

Important: Ensure that all wiring is secured in a position that avoids hot or moving parts to prevent damage to the vehicle or plow.

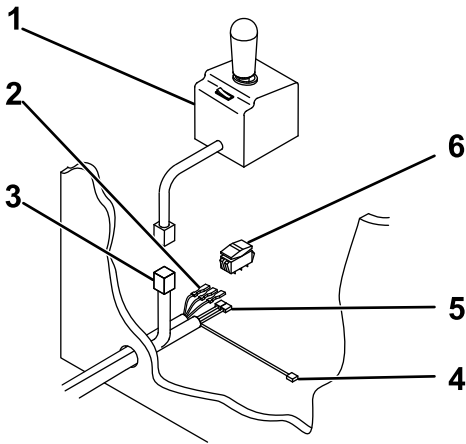

g215379

Figure 7

- | | |
|--------------------------|-------------------|
| 1. Plow controller | 4. Black/red wire |
| 2. Tractor harness wires | 5. Black wires |
| 3. Controller connector | 6. Rocker switch |

-
9. Connect the blue tractor harness wire to the bottom post on the rocker switch.
 10. Connect the black tractor harness wire to the center post on the rocker switch.
 11. Connect the red tractor harness wire to the top post on the rocker switch.
 12. Locate an available hole in the dash and mount the rocker switch through it.
 13. Continue the wiring installation from step 16 of the upfitter wiring installation manual.

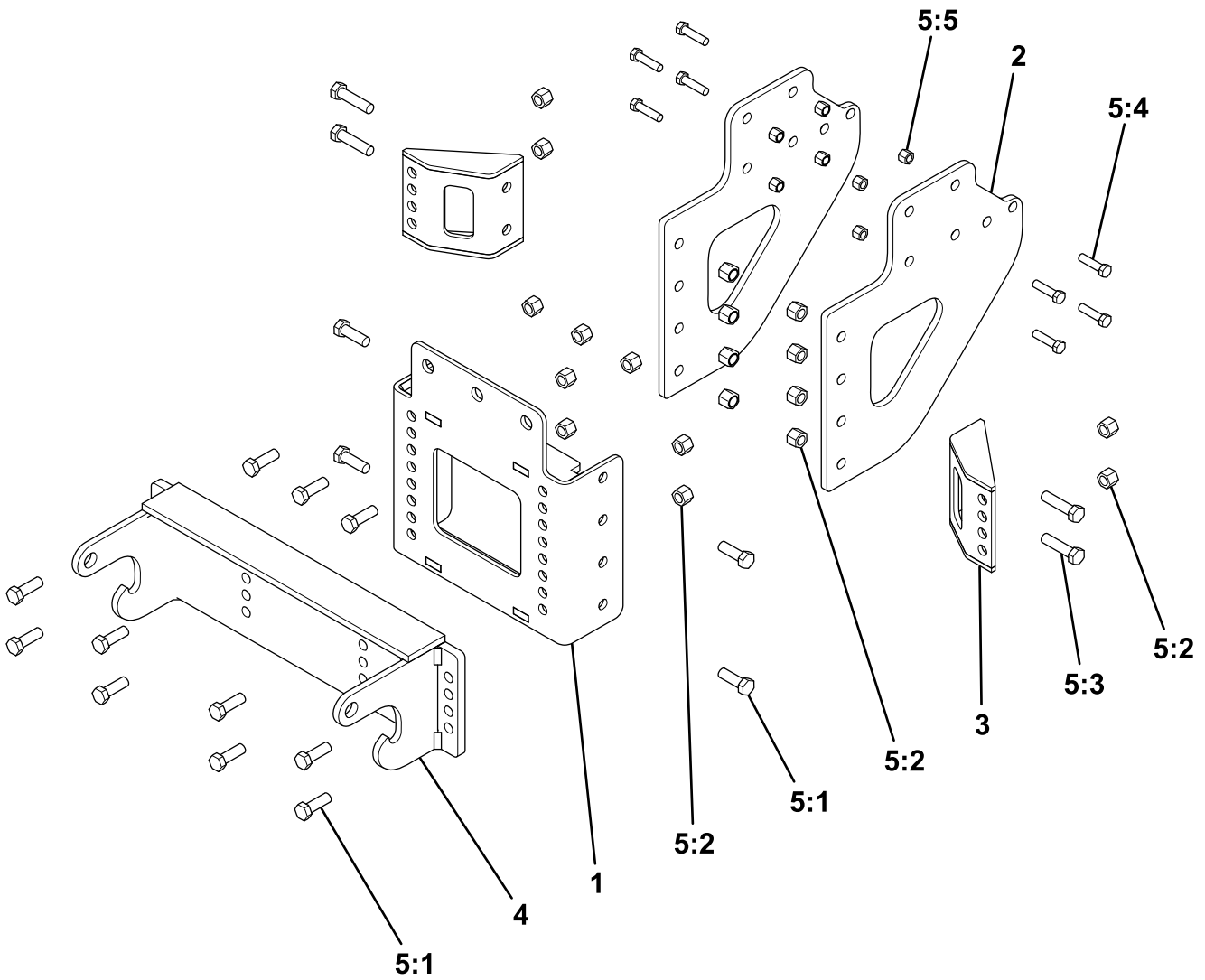

Parts

g216487

Ref.	Part Number	Qty.	Description	Ref.	Part Number	Qty.	Description
1	PBA11185	1	FRONT PLATE ASSEMBLY	5:4	HDW01719	8	HHCS, 3/8-16 X 1 1/2, NC, GR5, YZN
2	LTA11188	2	PUSHBEAM SIDE PLATE	5:5	HDW01720	8	NUT, 3/8-16, NYL INS, YZN
3	PBA11193	2	PUSHBEAM GUSSET WELDMENT				
4	PBA11196	1	HTX PUSHBEAM				
4	PBA19989	1	RT3 PUSHBEAM				
5	HDW11184	1	HARDWARE KIT				
5:1	HDW01728	15	HHCS, 1/2-13 X 1-1/2, NC, GR5, YZN				
5:2	HDW01748	19	NUT, 1/2-13, NYL INS, YZN				
5:3	HDW01755	4	HHCS, 1/2-13 X 2, GR5, YZN				

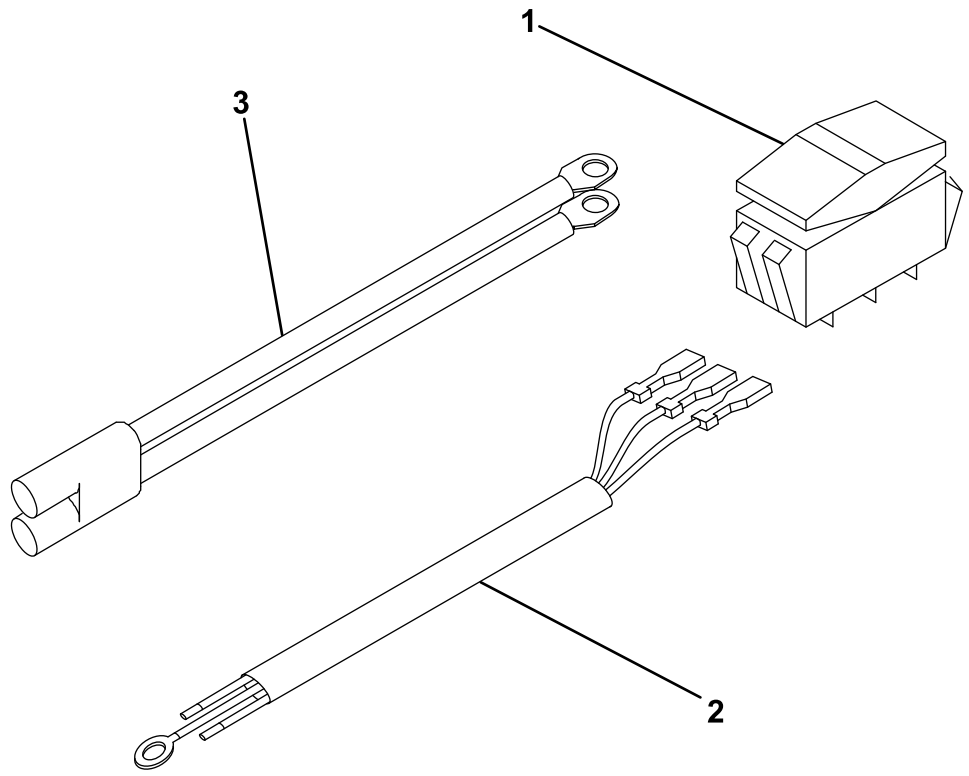

Parts

g215929

Ref.	Part Number	Qty.	Description
1	MSC11183	1	SWITCH, ROCKER, HEADLIGHT, HI-OFF-LOW
2	MSC11182	1	HARNESS-LIGHT, TRACTOR
3	HYD11132	1	POWER/GROUND CABLE, VEHICLE SIDE, 36

Notes:

BOSS

S N O W P L O W