

BOSS Products limited consumer warranty and BOSS Products commercial warranty policies are located at www.BOSSPlow.com.

Patents pending.

Safety

- Always follow the vehicle manufacturer's recommendations relating to system installation. For recommended vehicle models, refer to the *BOSS Snowplow Application Chart and Selection Guide*.
- Never disable, remove, or relocate any sensors or other components related to the operation of the air bags.
- To comply with federal regulations and to assure a safe vehicle, do not exceed the front gross-axle-weight rating (FGAWR), rear gross-axle-weight rating (RGAWR), and the gross-vehicle-weight rating (GVWR) at any time.
- Due to the variety of equipment that you can install on the vehicle and undercarriage, do not exceed the front gross-axle-weight rating (FGAWR), rear gross-axle-weight rating (RGAWR), and the gross-vehicle-weight rating (GVWR) at any time. This may require weighing the vehicle and adding ballast as necessary. It may also limit the payload capacity of the vehicle.

Installation

Determine the left and right sides of the machine from the normal operating position.

1. Park the machine on a level surface, shut off the engine, wait for all moving parts to stop, engage the parking brake, and remove the key.
2. Remove the front bumper of the vehicle.
3. Drill the existing holes on the vehicle frame that line up with the back holes of the sideplates to 14 mm (9/16 inches) as shown in [Figure 1](#).

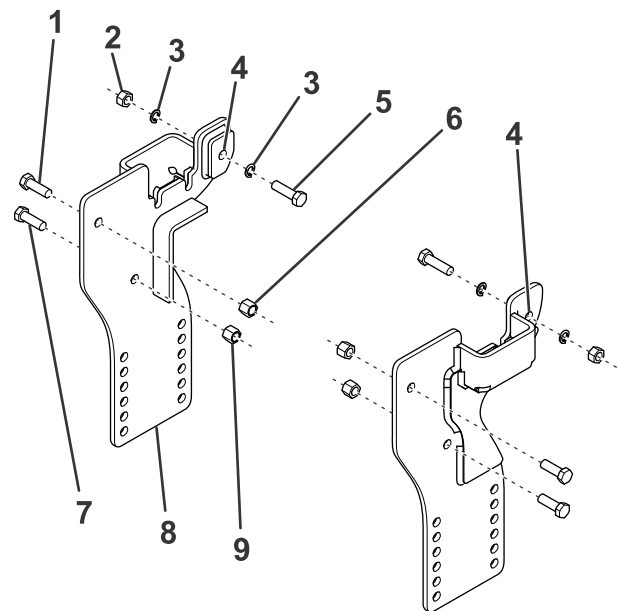

g302885

Figure 1

- | | |
|---------------------------------------|---------------------------------------|
| 1. Existing bolt | 6. Existing nut |
| 2. Nut | 7. Hex-head bolt (1/2 x 1-1/2 inches) |
| 3. Split lock washer | 8. Sideplate |
| 4. Sideplate back hole | 9. Locknut |
| 5. Hex-head bolt (1/2 x 1-3/4 inches) | |

4. Use the bolt puller to loosely secure the rear of the sideplates to the vehicle frame using 2 bolts (1/2 x 1-3/4 inches), 4 split lock washers, and 2 nuts ([Figure 1](#)).
5. Use the previously removed existing fasteners to secure the front of the sideplates ([Figure 1](#)).

6. Loosely secure the middle of the sideplates to the vehicle frame using 2 bolts (1/2 x 1-1/2 inches) and 2 locknuts ([Figure 1](#)).
7. Loosely secure the pushbeam to the sideplates using 8 bolts (1/2 x 1-1/2 inches) and locknuts ([Figure 2](#)).

Note: Refer to your plow *Owner's Manual* for the appropriate pushbeam height.

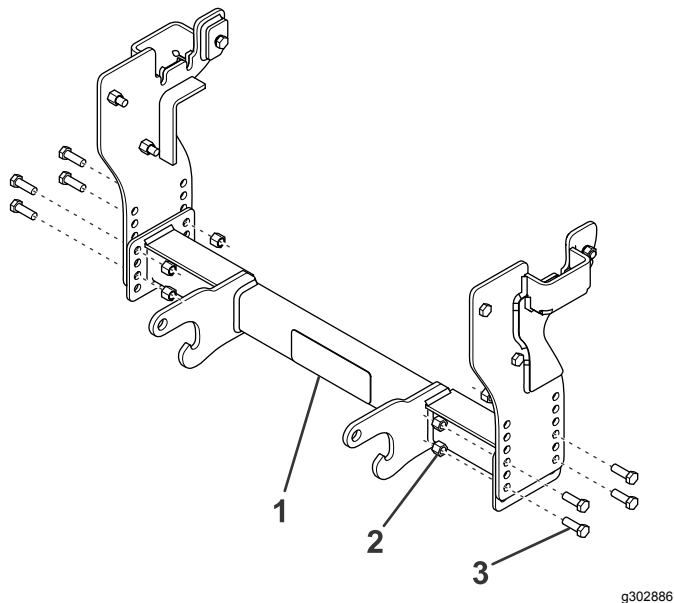
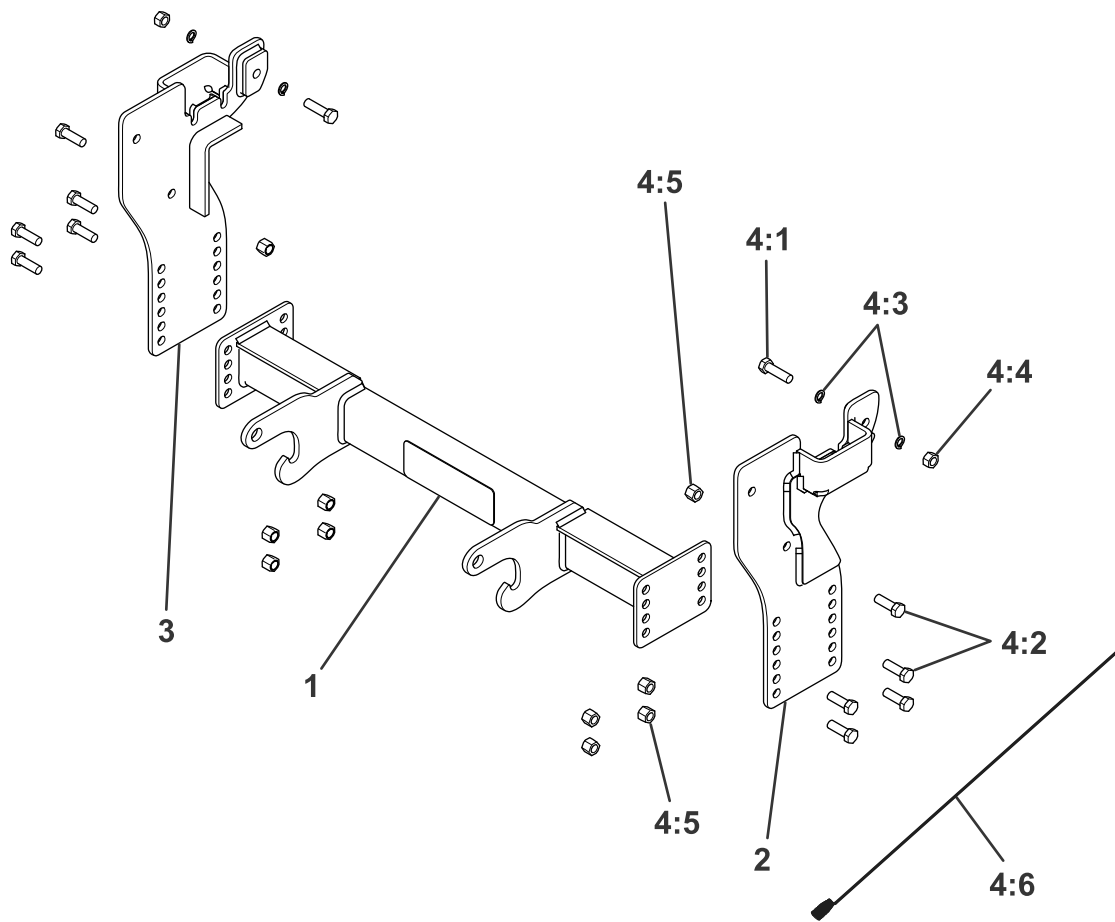

Figure 2

- | | |
|-------------|------------------------------|
| 1. Pushbeam | 3. Bolt (1/2 x 1-1/2 inches) |
| 2. Locknut | |

-
8. Torque the fasteners to 76 N·m (56 ft-lb).
 9. Install the previously removed front bumper.



g302884

Parts

Ref.	Part Number	Qty.	Description	Ref.	Part Number	Qty.	Description
1	PBA05277-03	1	PB ASM, RT3 SP, WRANG 07+, TACOMA 05+	4:5	HDW01748	10	NUT, 1/2-13, NYL INS, YZN
2	PBA11942-03	1	PB SPT PLT, DS, JEEP WRANGLER JL, 18+	4:6	MSC09670	2	BOLT PULLER, 1/2-13
3	PBA11943-03	1	PB SPT PLT, PS, JEEP WRANGLER JL, 18+				
4	HDW11957	1	FASTENER KIT, JEEP, WRANGLER JL 18+				
4:1	HDW01802	2	HHCS, 1/2-13 X 1-3/4, GR5 YELLOW ZDC				
4:2	HDW01728	10	HHCS, 1/2-13 X 1-1/2, NC, GR5, YZN				
4:3	HDW01732	4	WASHER, 1/2, SPLIT LOCK, YZN				
4:4	HDW02410	2	NUT, 1/2-13, FIN, FULL, YZN				

BOSS
S N O W P L O W