

BOSS Products limited consumer warranty and BOSS Products commercial warranty policies are located at www.BOSSPlow.com.

Patents pending.

Safety

- Always follow the vehicle manufacturer's recommendations relating to system installation.
- Due to the variety of equipment that you can install using the undercarriage, ensure that the gross-vehicle-weight rating (GVWR) is not exceeded at any time. You may need to weigh the vehicle and add ballast or limit the payload of the vehicle to compensate.

Installation

Determine the left and right sides of the machine from the normal operating position.

1. Park the machine on a level surface, shut off the engine, wait for all moving parts to stop, engage the parking brake, and remove the key.
2. Remove the vehicle front plate.
3. Loosely secure the top of the undercarriage skid plate to the vehicle frame using 2 bolts (3/8 inch), 4 washers, and 2 locknuts ([Figure 1](#)).

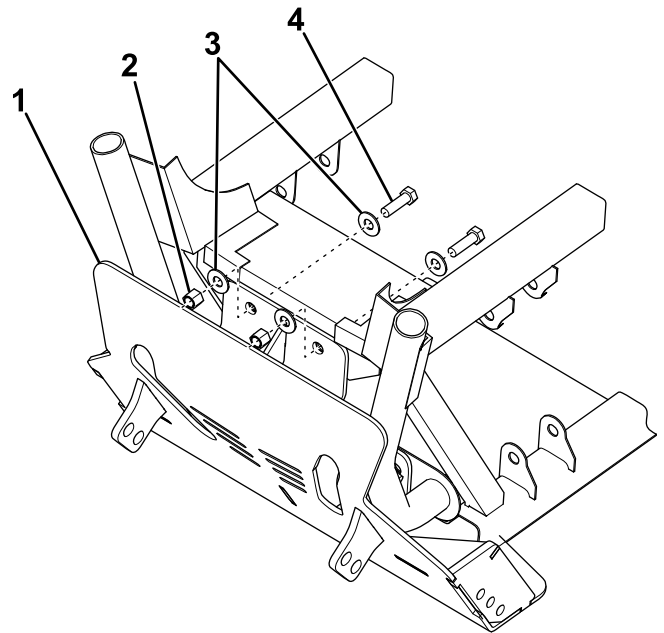

g279496

Figure 1

- | | |
|-----------------------|----------------------|
| 1. Skid plate | 3. Washer (3/8 inch) |
| 2. Locknut (3/8 inch) | 4. Bolt (3/8 inch) |

4. Loosely secure the middle of the undercarriage skid plate to the vehicle frame using 2 bolts (3/8 inch), 4 washers, and 2 locknuts ([Figure 2](#)).



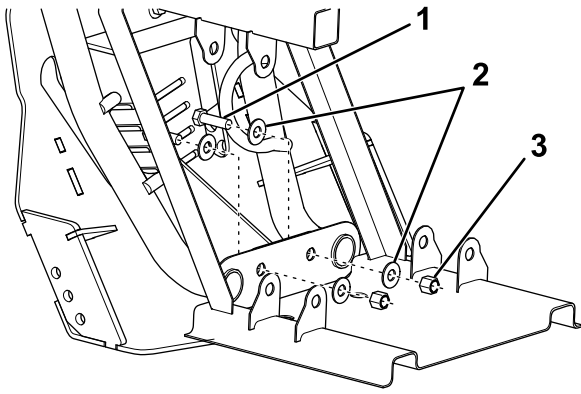

g279497

Figure 2

- | | |
|----------------------|-----------------------|
| 1. Bolt (3/8 inch) | 3. Locknut (3/8 inch) |
| 2. Washer (3/8 inch) | |

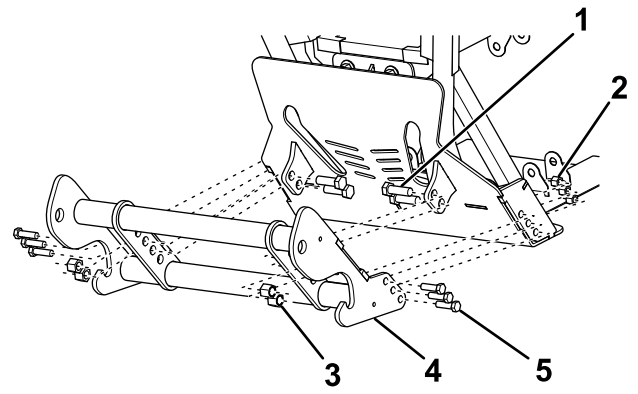

g279499

Figure 4

- | | |
|------------------------------|--------------------|
| 1. Bolt (1/2 x 1-1/4 inches) | 4. Pushbeam |
| 2. Locknut (3/8 inch) | 5. Bolt (3/8 inch) |
| 3. Locknut (1/2 inch) | |

-
5. Loosely secure the bottom of the undercarriage skid plate to the vehicle frame using 2 bolts (1/2 x 1-3/4 inches), 2 washers, and 2 locknuts (Figure 3).

Note: Refer to your plow *Owner's Manual* for the appropriate pushbeam height.

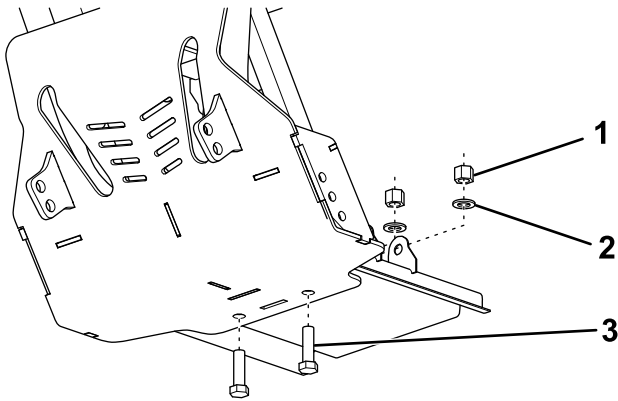

g279498

Figure 3

- | | |
|-----------------------|------------------------------|
| 1. Locknut (1/2 inch) | 3. Bolt (1/2 x 1-3/4 inches) |
| 2. Washer (1/2 inch) | |

-
6. Loosely secure the outside of the pushbeam assembly to the skid plate using 6 bolts (3/8 inch) and locknuts (Figure 4).

-
7. Loosely secure the inside of the pushbeam assembly to the skid plate using 4 bolts (1/2 x 1-1/4 inches) and locknuts (Figure 4).
8. Torque all the fasteners to the following specifications:
- 3/8 inch bolts to 31 N·m (23 ft-lb)
 - 1/2 inch bolts to 76 N·m (56 ft-lb)

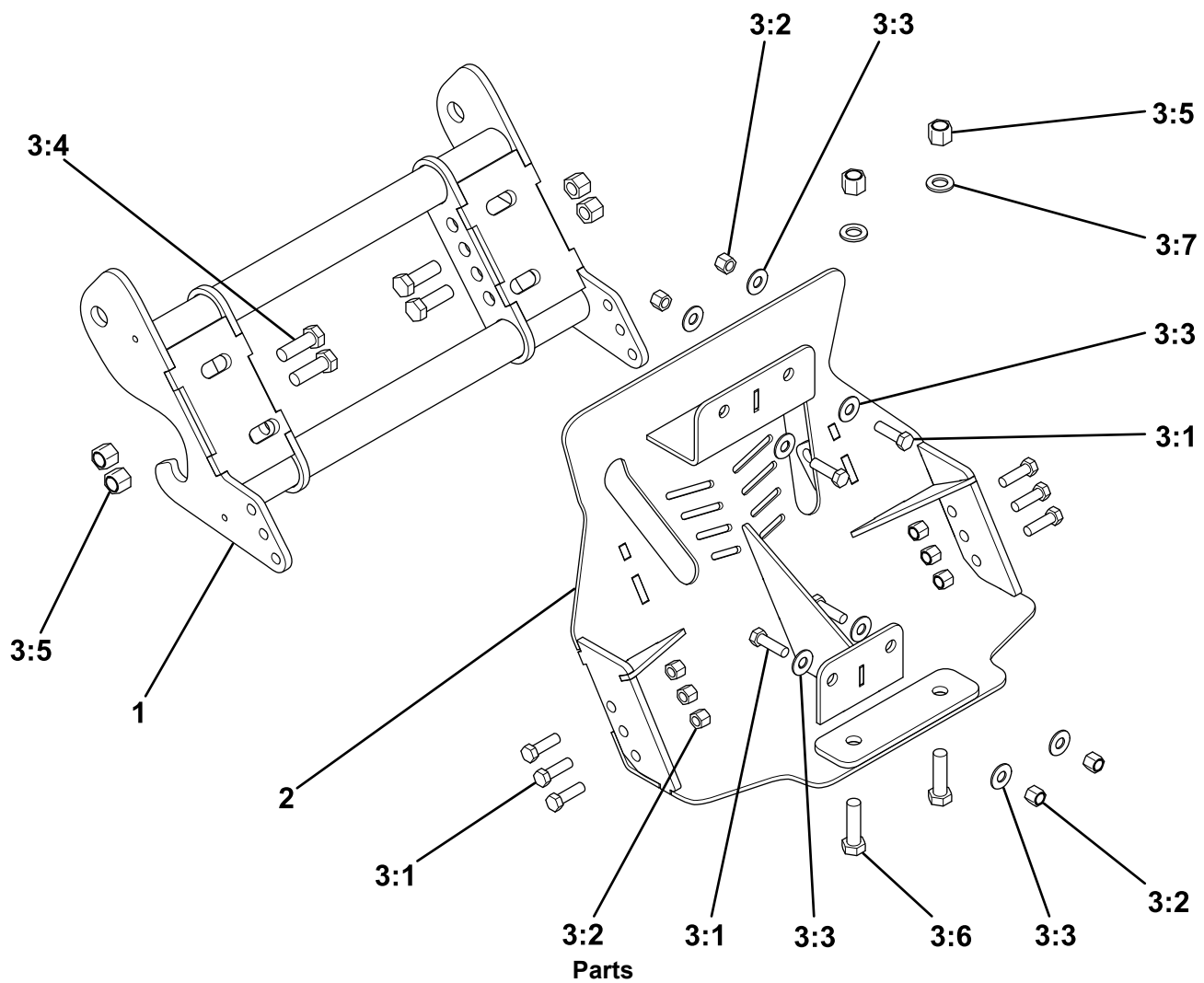

Parts

g279495

Ref.	Part Number	Qty.	Description	Ref.	Part Number	Qty.	Description
1	PBA12535-03	1	PUSHBEAM ASM RT3, UTV, COMMON	3:5	HDW01748	6	NUT, 1/2-13, NYL INS, YZN
2	LTA12186-03	1	SKID PLT WLDMT, TEXT STPDE/HAVOC	3:6	HDW01802	2	HHCS, 1/2-13 X 1-3/4, GR5 YELLOW ZDC
3	HDW12193	1	FASTNER KIT, TEXTRON STPDE/HAVOC, 2017+	3:7	HDW01729	2	WASHER, 1/2, F436 HARD, F/W, YZN
3:1	HDW01771	10	HHCS, 3/8-16 X 1-1/4, NC, GR5, YZN				
3:2	HDW01720	10	NUT, 3/8-16, NYL INS, YZN				
3:3	HDW01733	8	WASHER, 3/8, USS FLAT, YZN				
3:4	HDW01728	4	HHCS, 1/2-13 X 1-1/2, NC, GR5, YZN				

BOSS
S N O W P L O W