

BOSS Products limited consumer warranty and BOSS Products commercial warranty policies are located at www.BOSSPlow.com.

Patent: www.ttcopats.com.

Safety

- Always follow the vehicle manufacturer's recommendations relating to system installation. For recommended vehicle models, refer to the *BOSS Snowplow Application Chart and Selection Guide*.
- Never disable, remove, or relocate any sensors or other components related to the operation of the air bags.
- To comply with federal regulations and to assure a safe vehicle, do not exceed the front gross-axle-weight rating (FGAWR), rear gross-axle-weight rating (RGAWR), and the gross-vehicle-weight rating (GVWR) at any time.
- Due to the variety of equipment that you can install on the vehicle and undercarriage, do not exceed the front gross-axle-weight rating (FGAWR), rear gross-axle-weight rating (RGAWR), and the gross-vehicle-weight rating (GVWR) at any time. This may require weighing the vehicle and adding ballast as necessary. It may also limit the payload capacity of the vehicle.

Installation

Determine the left and right sides of the machine from the normal operating position.

1. Park the machine on a level surface, shut off the engine, wait for all moving parts to stop, engage the parking brake (if equipped), and remove the key.
2. Remove the 4 bolts from the front lower plastic cover.
3. If equipped, remove the factory winch mount.
4. Relocate the winch solenoid to the rear shelf of the undercarriage assembly.
5. Loosely install the front of the undercarriage assembly to the machine frame, in the winch mount location, using 4 bolts (3/8-16 x 1-1/4 inches) and 4 nuts (3/8 inch).

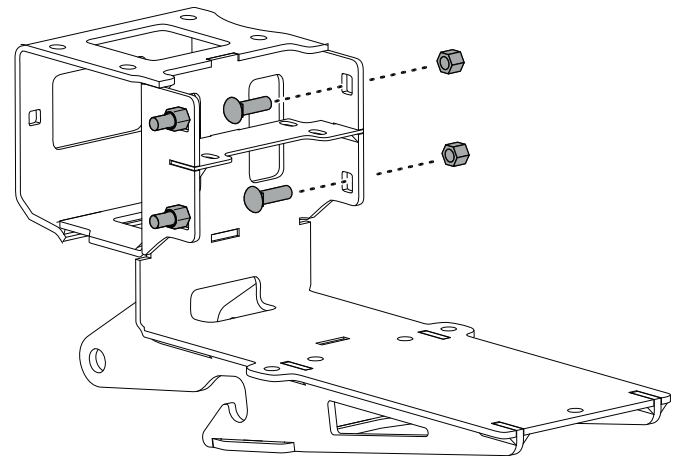

g369164

Figure 1

6. Loosely install the rear of the undercarriage assembly to the machine using 1 bolts (3/8-16 x 1-1/2 inches), 1 washer, and 1 nuts (3/8 inch).

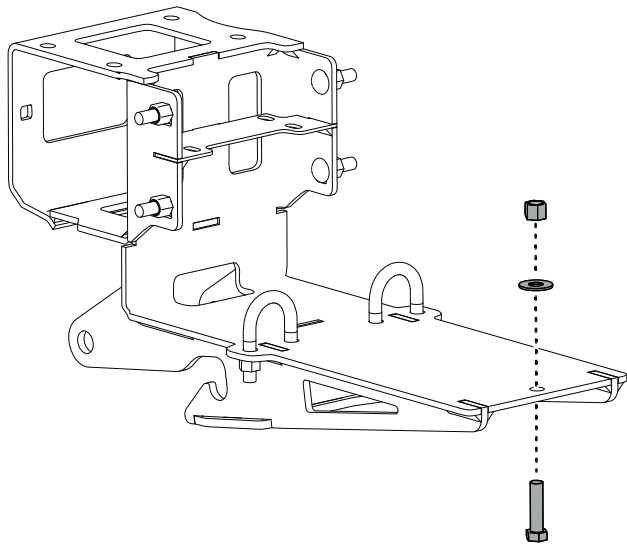

g369166

Figure 2

-
7. Loosely install the middle of the undercarriage assembly to the machine using 2 U-bolts and 4 nuts (3/8 inch).

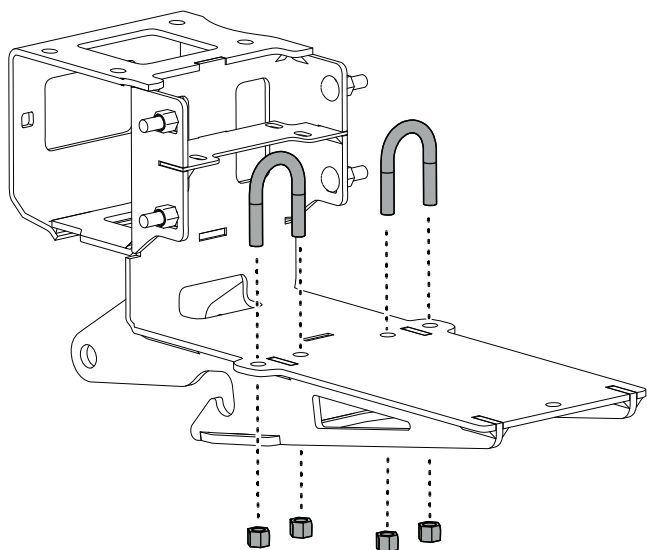

g369165

Figure 3

-
8. Torque the bolts (3/8 inch) to 31 N·m (23 ft-lb).
 9. Install the lower front plastic cover with original fasteners.

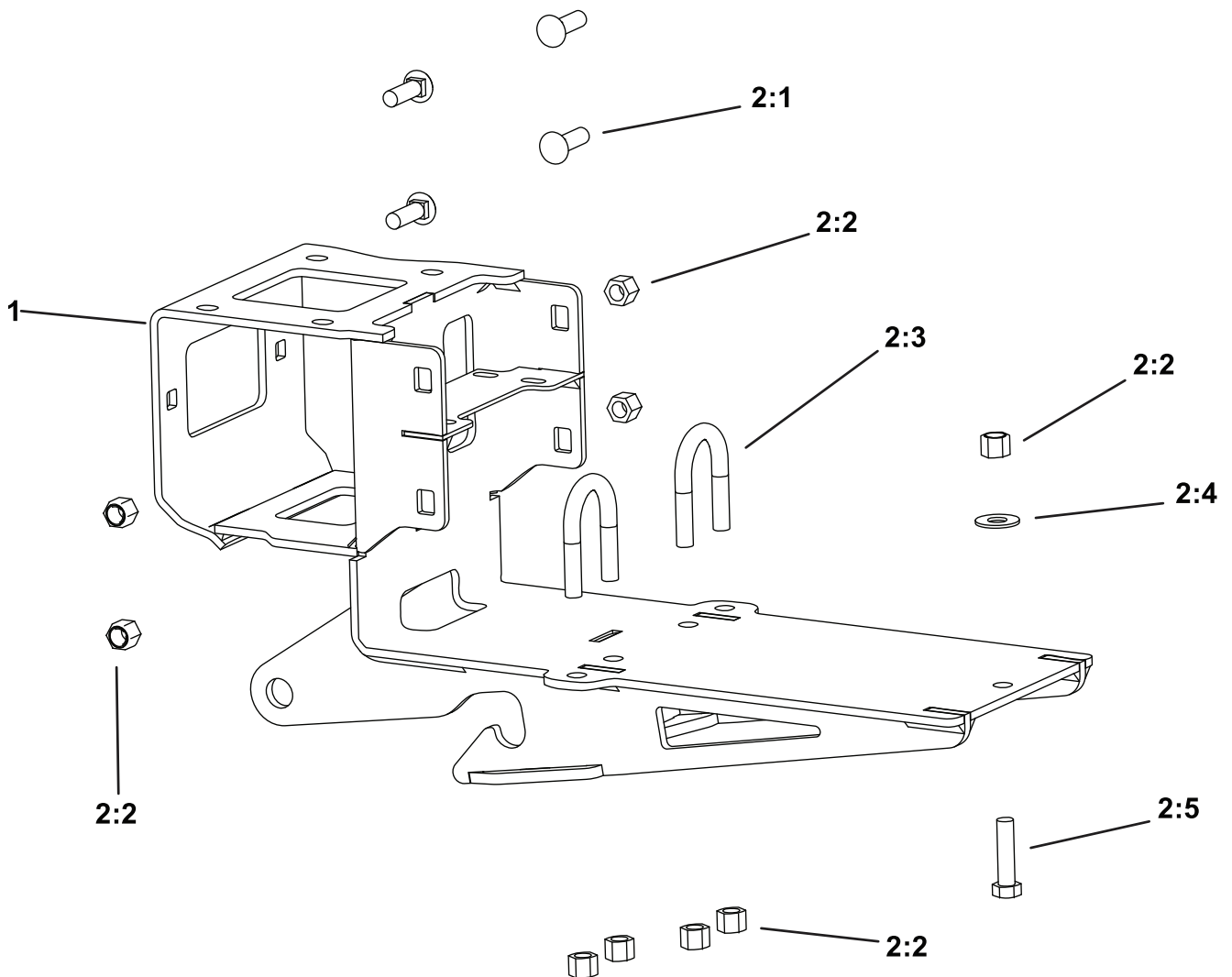

Parts

g369163

Ref.	Part Number	Qty.	Description
1	LTA 14787	1	UNDERCARRAIGE ASSEMBLY
2	HDW14793	1	FASTENER KIT
2:1	HDW05576	4	BOLT, CARRIAGE, 3/8-16 X 1-1/4, GR5, YZN
2:2	HDW01720	9	NUT, 3/8-16, NYL INS, YZN
2:3	HDW13649	2	BOLT-U, RD [3/8-16 X 1.25 X 2.25, CZ]
2:4	HDW01733	1	WASHER, 3/8, USS FLAT, YZN
2:5	HDW01719	1	HHCS, 3/8-16 X 1 1/2, NC, GR5, YZN

BOSS
S N O W P L O W