



P.O. Box 787
Iron Mountain, MI 49801
United States

Owner's Manual

Plow Side Kit

Groundsmaster® 360/7200/7210

Part No. MSC14175—Serial No. 40000000 and Up

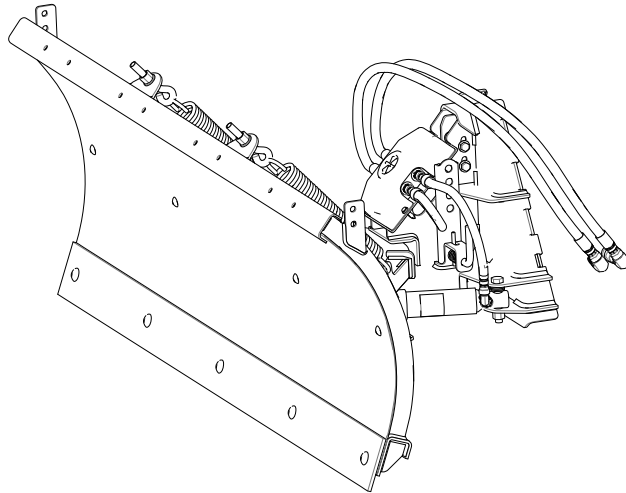

This product complies with all relevant European directives; for details, please see the separate product specific Declaration of Conformity (DOC) sheet.

BOSS Products limited consumer warranty and BOSS Products commercial warranty policies are located at www.bossplow.com.

Patents www.ftcopats.com.

Introduction

Note: This plow attaches to the Groundsmaster 7200 or 7210 with the Polar Trac kit or the Groundsmaster 360 with the Quick-Attach System.

The straight-blade plow is intended to be used on a Toro ride-on, multi-purpose machine. The blade is designed to hydraulically change its angle as needed for snow removal. Using this product for purposes other than its intended use could prove dangerous to you and bystanders.

Read this information carefully to learn how to operate and maintain your product properly and to avoid injury and product damage. You are responsible for operating the product properly and safely.

Visit www.bossplow.com for product safety and operation training materials, accessory information, help finding a dealer, or to register your product.

Whenever you need service, genuine BOSS parts, or additional information, contact an Authorized BOSS Dealer or BOSS Technical Service (1-800-286-4155) and have the model and serial numbers of your product ready. [Figure 1](#) identifies the location of the model and serial numbers on the product. Write the numbers in the space provided.

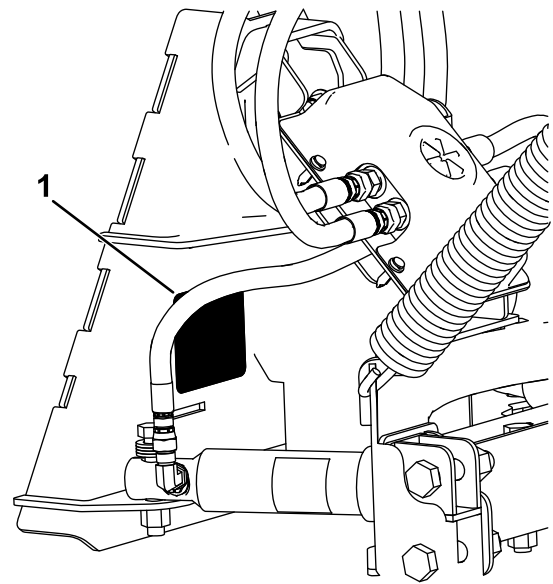

g324605

Figure 1

1. Model and serial number location

Date Purchased	_____
Model No.	_____
Serial No.	_____
Blade Crate Serial No.	_____

This manual identifies potential hazards and has safety messages identified by the safety-alert symbol ([Figure 2](#)), which signals a hazard that may cause serious injury or death if you do not follow the recommended precautions.



g000502

Figure 2

Safety-alert symbol

This manual uses 2 words to highlight information. **Important** calls attention to special mechanical information and **Note** emphasizes general information worthy of special attention.

Contents

Safety	3
Preparation.....	3
Operation.....	3
Safety and Instructional Decals	4
Setup	5
Preparing the Machine.....	5
Installing the Required Kits	5
Installing the Plow.....	5
Installing the Plow onto the Machine	6
Installing the Hydraulic Hoses.....	7
Product Overview	7
Controls	7
Specifications	8
Operation	8
Operating the Plow	8
Operating Tips	8
Maintenance	9
Recommended Maintenance Schedule(s)	9
.....	9
Maintenance	9
Storage	9
Storing the Plow	9
Removing the Plow from Storage.....	9
Troubleshooting	10

Safety

Improper use or maintenance by the operator or owner can result in injury. To reduce the potential for injury, comply with these safety instructions and always pay attention to the safety-alert symbol **▲**, which means **Caution, Warning, or Danger**—personal safety instruction. Failure to comply with the instruction may result in personal injury or death.

Preparation

- Read the *Owner's Manual* before operating or servicing the plow.
- Always follow the vehicle manufacturer's recommendations relating to system installation.
- Ensure that only trained personnel installs and performs maintenance on the equipment and hydraulic components.
- Always wear appropriate personal protective equipment when loading, unloading, and servicing the plow. Wear substantial, slip-resistant footwear, long pants, and eye protection.

Operation

- Use a 500 kg (1/2 ton) minimum lifting device to move heavy plow components.
- Never put any part of your body between the plow and the vehicle.
- When transporting the plow, ensure that it is properly secured. Instructions are available at www.bosspow.com.
- When transporting the vehicle, position the plow so as not to block your vision or headlights.
- Do not change the blade position when traveling.
- Do not exceed 16 km/h (10 mph) while transporting.
- Always lower the blade when the vehicle is not in use.
- Do not operate the machine while ill, tired, or under the influence of alcohol or drugs.
- Always follow the vehicle manufacturer's recommendations for proper parking procedures.
- Overloading the plow could result in an accident or damage. Never exceed the rated operating capacity for the vehicle.
- Ensure that you do not exceed the gross-vehicle-weight rating (GAWR) at any time.
- Turn the vehicle and plow off before filling, servicing, or cleaning it.
- Do not climb into or ride on the plow.

- Keep your hands, feet, and clothing away from moving parts and mounting points.
- Use your full attention while operating the machine. Do not engage in any activity that

causes distractions; otherwise, injury or property damage may occur.

- Do not operate the plow within 8 m (25 ft) of bystanders.

Safety and Instructional Decals



Safety decals and instructions are easily visible to the operator and are located near any area of potential danger. Replace any decal that is damaged or missing.

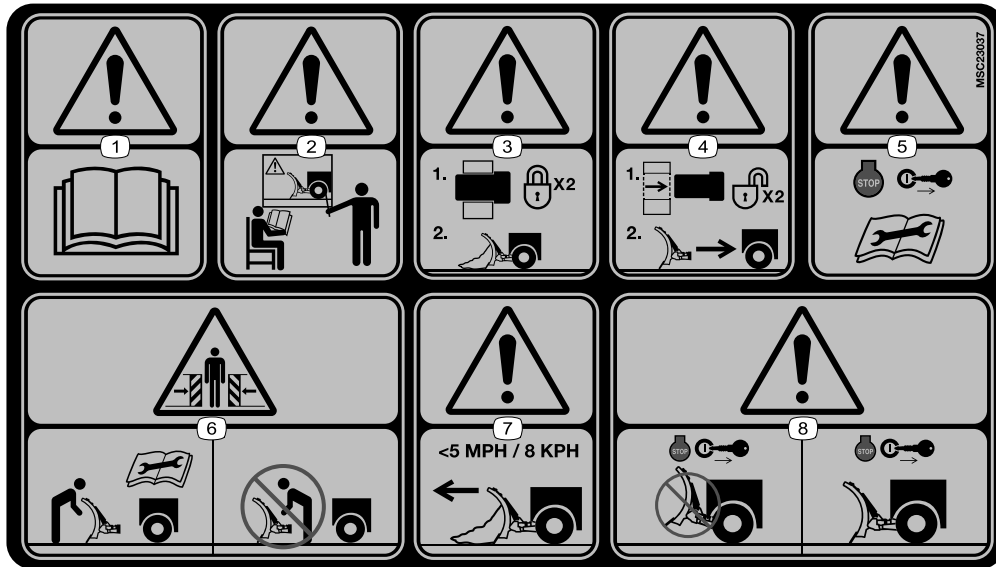

MSC23037

decalmsc23037

1. Warning—read the *Owner's Manual*.
2. Warning—all operators should be trained before operating the machine.
3. Warning—coupler must be locked before plowing.
4. Warning—coupler must be unlocked to remove the plow.
5. Warning—shut off the engine, remove the key, and read the *Owner's Manual* before performing maintenance.
6. Crushing hazard—do not stand between the plow and vehicle during maintenance.
7. Warning—do not exceed 8 km/h (5 mph) when plowing.
8. Warning—lower the plow when the vehicle is not in use.

Setup

Note: Determine the left and right sides of the machine from the normal operating position.

Preparing the Machine

Remove the Attachment from the Machine (if required)

Refer to the attachment *Installation Instructions*.

Installing the Required Kits

Install the following kits:

- Groundsmaster 360: Quick Attach System (Model 30509)
- Groundsmaster 7200: Polar Trac Kit (Model 30675)

Installing the Plow

1. Loosely secure the 2 mounting brackets to the plow using 2 bolts (5/8 inch) and nuts.

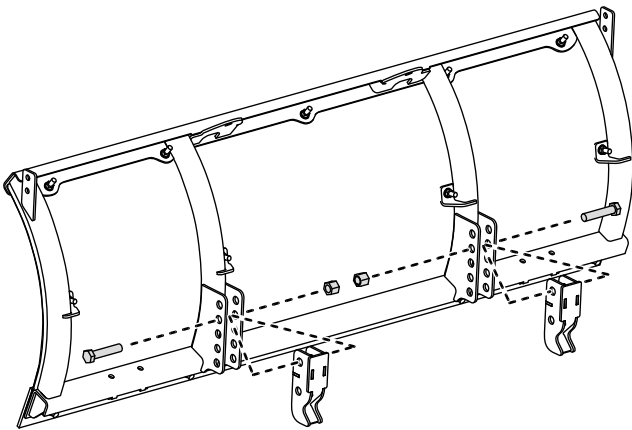

Figure 3

g325498

2. Loosely secure the push frame to the plow and mounting brackets using 2 bolts (5/8 inch) and nuts.

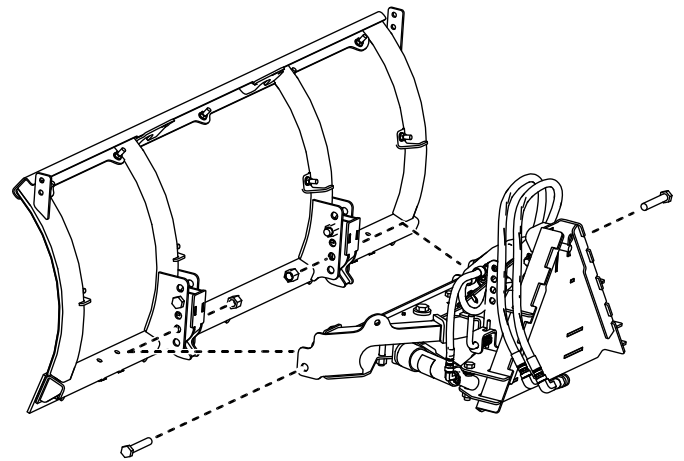

Figure 4

g324607

3. Torque all 4 bolts to 203 N·m (150 ft-lb).

Note: Do not overtighten the fasteners; ensure that the push frame can pivot freely.

4. Hook the 2 trip springs through the holes on the push frame.

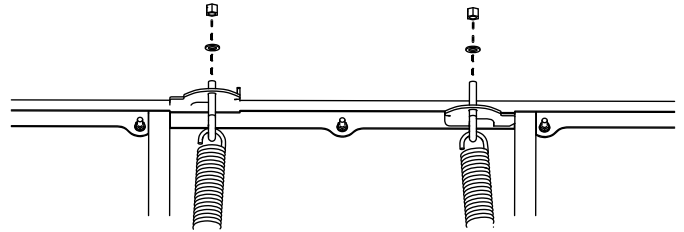

Figure 5

g325499

5. Hook the other ends of the trip springs to 2 eyebolts.
6. Insert the threaded end of the eyebolts through the holes on the plow blade and secure them using 2 washers (1/2 inch) and locknuts.
7. Tighten the nylon locknuts until there is a gap of 0.8 mm (1/32 inch) between the trip spring coils.

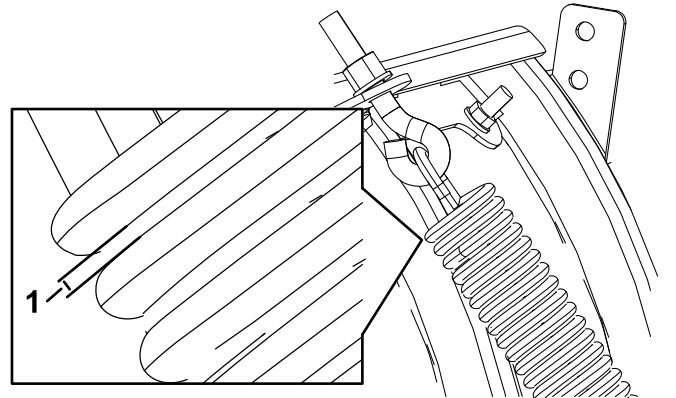

Figure 6

g324777

1. 0.8 mm (1/32 inch) gap

Installing the Plow onto the Machine

1. Move the machine into position behind the attachment adapter.
2. Raise the machine adapter into the attachment adapter.
3. Insert the locking pin through the adapters and secure it with a hairpin cotter.

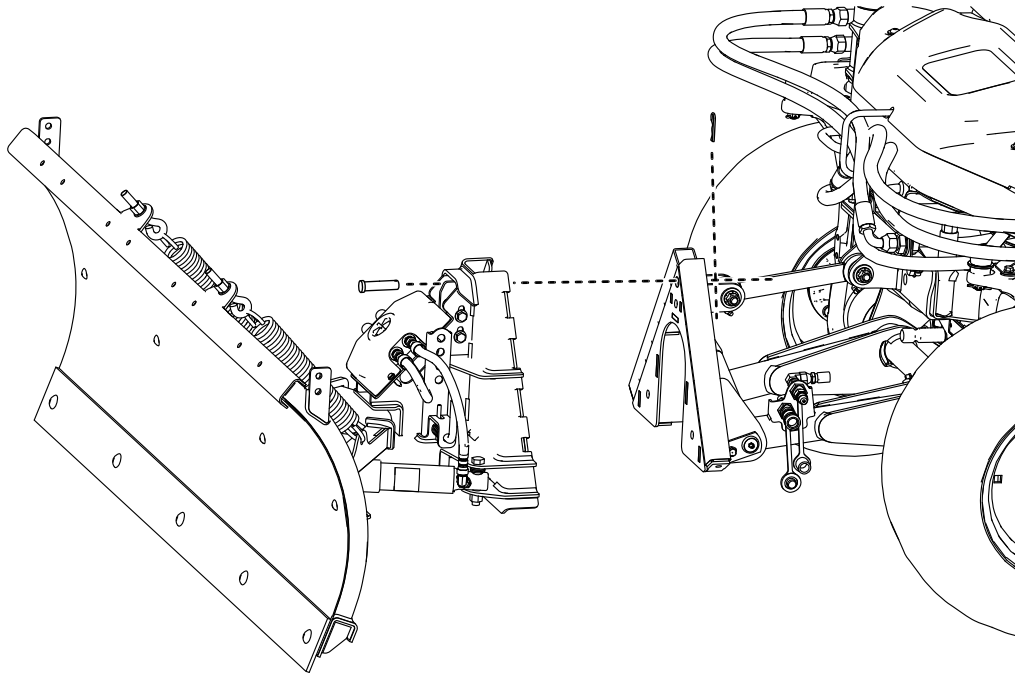

g324610

Figure 7

Groundsmaster 360 with the Quick-Attach System

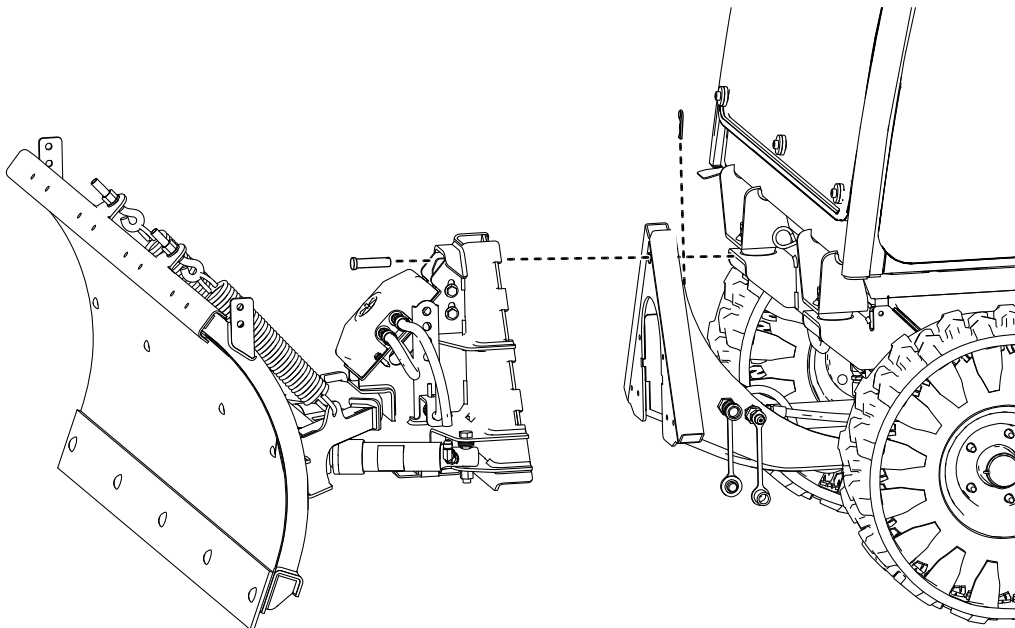

g324611

Figure 8

Groundsmaster 7200/7210 with the Polar Trac Kit

Installing the Hydraulic Hoses

Install the hoses to the quick disconnect fittings.

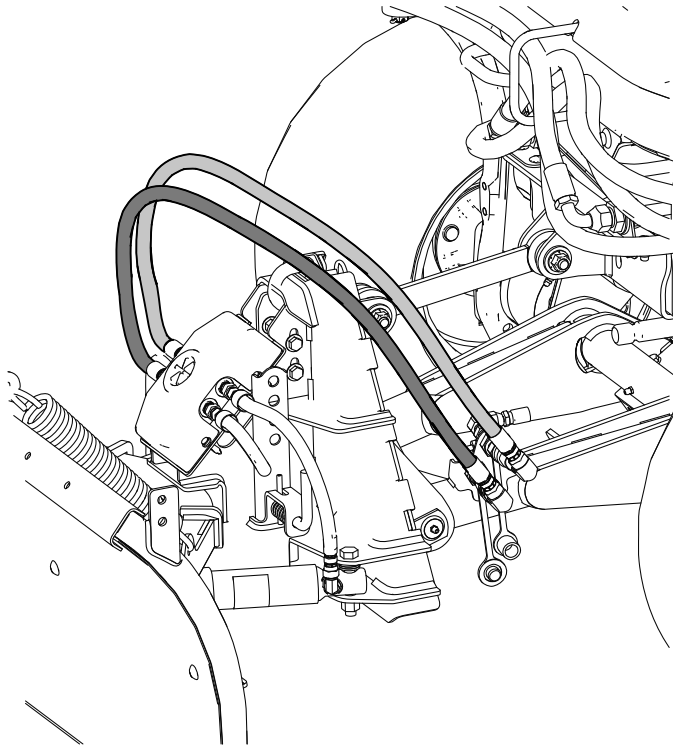

Figure 9

g324609

Product Overview

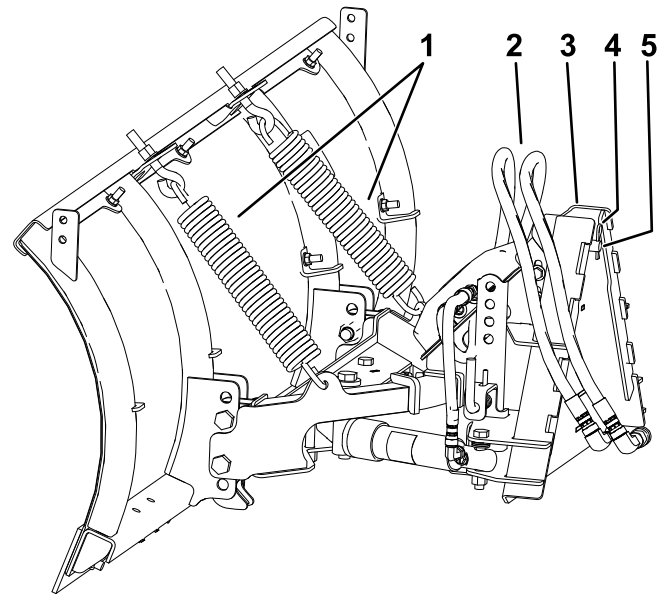

Figure 10

g324606

- 1. Trip springs
- 2. Hydraulic hose quick couplers
- 3. Attachment plate
- 4. Locking pin
- 5. Cotter pin

Controls

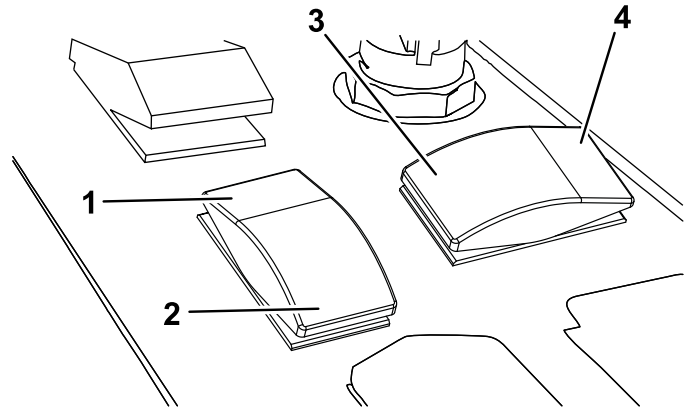

Figure 11

g268384

Groundsmaster 360 with the Quick-Attach System

- 1. Raise the plow
- 2. Lower the plow
- 3. Angle the plow to the left.
- 4. Angle the plow to the right.

Operation

Operating the Plow

Refer to your machine *Operator's Manual* for instructions on operating attachments.

Operating Tips

- Become familiar with the area you are plowing; hidden obstructions such as curbs and pipes can damage your plow or machine.
- Do not let snow accumulate; always plow with the storm.
- Lower the plow when not in use to prevent possible injury.
- Always plow at a safe speed in case you hit hidden obstructions.
- When transporting the machine, do not block your vision with the plow.
- Do not change the plow position while plowing.
- For more plowing tips, visit www.bossplow.com.

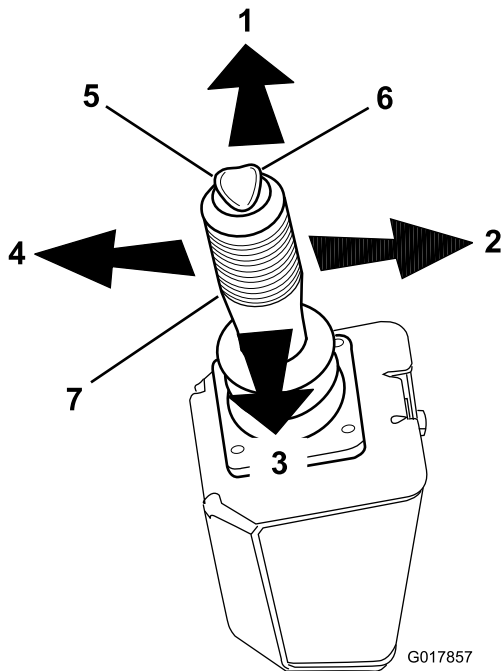

Figure 12

Optional Kit for GM 360

1. Raise the plow
2. Angle the plow right
3. Lower the plow
4. Angle the plow left
5. Toggle left
6. Toggle right
7. Joystick

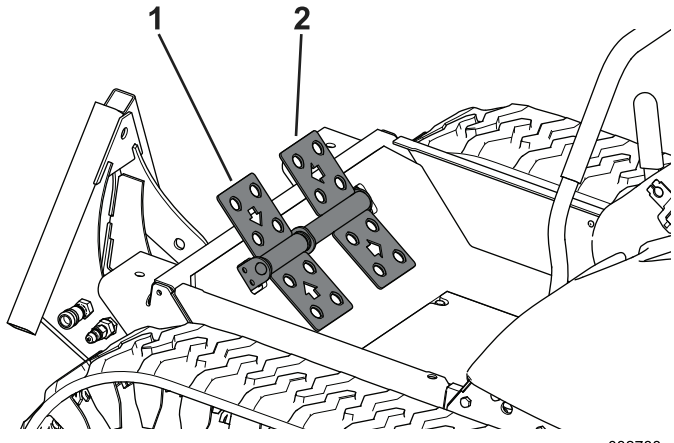

Figure 13

Groundsmaster 7200 with the Polar Trac Kit

1. Raise and lower the plow
2. Angle the plow

Specifications

Blade Width	Blade Height	Weight
1.52 m (5 ft)	55.8 cm (22 inches)	104 kg (229 lb)

Maintenance

Recommended Maintenance Schedule(s)

Maintenance Service Interval	Maintenance Procedure
After the first 2 hours	<ul style="list-style-type: none">• Tighten all hardware.
Before each use or daily	<ul style="list-style-type: none">• Check the hydraulic cylinders.• Check the hydraulic lines and hoses.• Check all fasteners, pins, retainers, nuts, and bolts.• Check the cutting edge for wear.
Before storage	<ul style="list-style-type: none">• Lightly sand and use touch-up paint on painted areas that are scratched, chipped, or rusted.• Grease the hydraulic cylinder rods.• Lightly sand and use touch-up paint on painted areas that are scratched, chipped, or rusted.

Maintenance

- Check the hydraulic lines and hoses daily for leaks, kinked lines, loose mounting supports, wear, loose fittings, weather deterioration, and chemical deterioration. Make all necessary repairs before operating.
- Check the hydraulic cylinders daily for leaks, rust, or pitting on the rods. Make all necessary repairs before operating.
- Check the cutting edge daily for wear. If the cutting edge is worn down either flip or replace it.
- Check all fasteners, pins, retainers, nuts, and bolts daily to ensure that they are secure. Torque them to the appropriate value if they are loose.

Storage

Storing the Plow

1. Drive the plow to your storage location and remove the plow; refer to your machine *Operator's Manual*.
2. Grease any exposed metal on the hydraulic cylinder rods.
3. Lightly sand and use touch-up paint on painted areas that are scratched, chipped, or rusted.
4. Loosen the trip springs.

Removing the Plow from Storage

1. Check the torque of all fasteners; tighten as necessary.
2. Check the hydraulic lines and hoses for cracks or leaks.
3. Check the cutting edge for wear.
4. Tighten the trip springs.
5. Lightly sand and use touch-up paint on painted areas that are scratched, chipped, or rusted.
6. Attach the plow to the machine; refer to your machine *Operator's Manual*.
7. Move the plow through its range of motion to check the hydraulic cylinder rods.

Troubleshooting

Problem	Possible Cause	Corrective Action
Oil leaks from the hydraulic cylinders.	<ol style="list-style-type: none"><li data-bbox="581 216 802 243">1. The hose is bad.<li data-bbox="581 310 829 338">2. The cylinder is bad.<li data-bbox="581 344 889 371">3. The cylinder rod is pitted.	<ol style="list-style-type: none"><li data-bbox="1057 216 1513 296">1. Check the hose for leaks. Apply thread locking compound to the connection or replace the hose.<li data-bbox="1057 310 1321 338">2. Replace the cylinder.<li data-bbox="1057 344 1414 371">3. Polish the rod with steel wool.
The blade trips too easily.	<ol style="list-style-type: none"><li data-bbox="581 390 1029 420">1. The trip springs are loose or damaged.	<ol style="list-style-type: none"><li data-bbox="1057 390 1500 447">1. Tighten the springs or replace them if they are damaged.

Notes:

BOSS
S N O W P L O W