



Bumper Trim

2015–2019 Chevy 2500/3500 Truck

Part No. MSC09279—Serial No. 40000000 and Up

Form No. MSC14746 Rev A

Installation Instructions

BOSS Products limited consumer warranty and BOSS Products commercial warranty policies are located at www.BOSSPlow.com.

Safety

- Always follow the vehicle manufacturer's recommendations relating to snowplow installation. For recommended vehicle models, refer to the *BOSS Snowplow Application Chart and Selection Guide*.
- Never disable, remove, or relocate any sensors or other components related to the operation of the air bags.
- To comply with federal regulations and to assure a safe vehicle, do not exceed the front gross-axle-weight rating (FGAWR), rear gross-axle-weight rating (RGAWR), and the gross-vehicle-weight rating (GVWR) at any time.
- Due to the variety of equipment that you can install on this vehicle, do not exceed the front gross-axle-weight rating (FGAWR), rear gross-axle-weight rating (RGAWR), and the gross-vehicle-weight rating (GVWR) at any time. This may require weighing the vehicle and adding ballast as necessary. It may also limit the payload capacity of the vehicle. It is the operator's responsibility to verify that these ratings are not exceeded.



Installation

1. Park the vehicle on a level surface, shut off the engine, and remove the key.
2. Remove the grill to access the bumper mounting bolts.
3. Disconnect any electrical connectors that may prevent bumper removal.
4. Remove the bumper and place it face down on a suitable surface that will not damage the front surface of the bumper.
5. Remove the bolts that fasten the rear brackets to the bumper shell (Figure 1).

Important: Be careful to remove any sensors, lights, or wiring that may be fastened to the bumper shell.

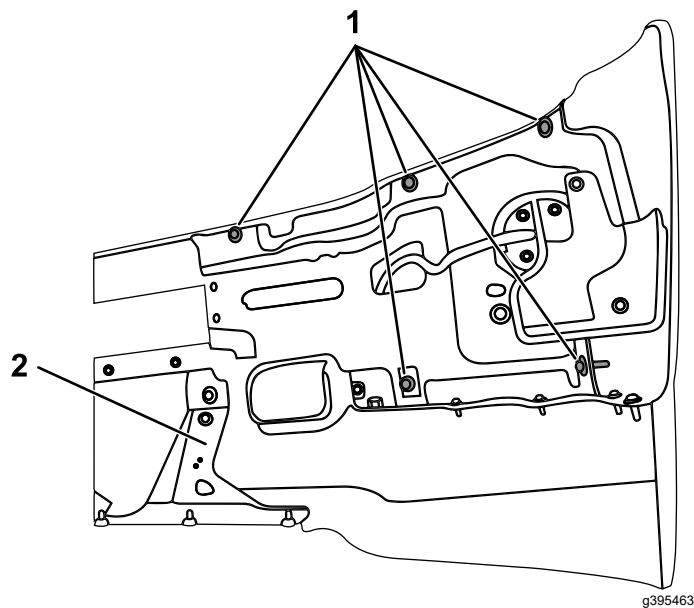

Figure 1

1. Remove these bolts (repeat step on other side)
2. Air dam bracing

-
6. Remove the air dam bracing and the trim piece to expose the air dam mounting bolts.
 7. Remove the air dam.
 8. Remove the J-nuts from the existing air dam, install them on the new bumper trim, insert the trim piece, and install the existing hardware.

Note: Retain any extra hardware and store it with the existing air dam.

Note: If you are installing a license plate, use the existing license plate hardware or other appropriately-sized bolts.

9. Install the rear brackets to the bumper shell and connect any previously-removed sensors, lights, or wiring.

Note: Retain any extra hardware, including the air dam bracing, in case you remove the undercarriage.

10. Install the bumper and grill to the vehicle and ensure that the fit and finish is restored to its original condition.

Note: If you might install the existing trim in the future, save it.