



P.O. Box 787  
Iron Mountain, MI 49801  
United States

# Owner's Manual

## 4ft and 5ft Plow

### Grandstand® Multi Force® Snow Machine or Mower

Part No. MSC13960

Part No. STB13567B

Part No. MSC14780

Part No. STB13759B

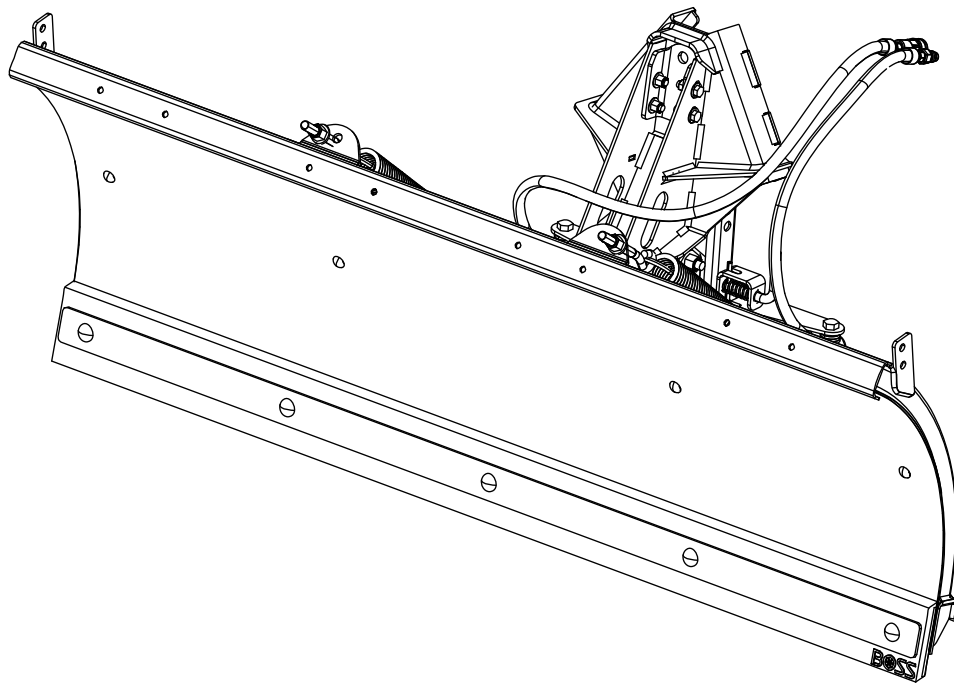

# Contents

- Safety ..... 3
  - Preparation..... 3
  - Operation..... 3
  - Safety and Instructional Decals ..... 3
- Setup ..... 4
  - Installing the Trip Stops and Urethane Blade..... 4
  - Installing the Push Frame ..... 4
  - Mounting the Plow ..... 5
- Product Overview ..... 7
  - Controls ..... 7
- Operation ..... 7
  - Mounting the Plow ..... 7
  - Removing the Plow ..... 7
  - Operating Tips ..... 8
- Maintenance ..... 9
  - Recommended Maintenance Schedule(s) ..... 9
  - ..... 9
  - Maintenance ..... 9
    - Flipping or Replacing the Cutting Edge ..... 9
- Storage ..... 10
  - Storing the Plow ..... 10
  - Removing the Plow from Storage..... 10
- Troubleshooting ..... 11
- Schematics ..... 12

# Introduction

Whenever you need service, genuine BOSS parts, or additional information, contact an Authorized Service Dealer or BOSS Customer Service and have the model and serial numbers of your product ready. Write the numbers in the space provided.

<b>Date Purchased</b>	_____
<b>Model No.</b>	_____
<b>Serial No.</b>	_____
<b>Blade Crate Serial No.</b>	_____

This manual identifies potential hazards and has safety messages identified by the safety-alert symbol (Figure 1), which signals a hazard that may cause serious injury or death if you do not follow the recommended precautions.



**Figure 1**

g000502

1. Safety-alert symbol

This manual uses 2 words to highlight information. **Important** calls attention to special mechanical information and **Note** emphasizes general information worthy of special attention.

# Safety

Improper use or maintenance by the operator or owner can result in injury. To reduce the potential for injury, comply with these safety instructions and always pay attention to the safety-alert symbol , which means: **Caution, Warning, or Danger**—personal safety instruction. Failure to comply with the instruction may result in personal injury or death.

## Preparation

- Read the *Owner's Manual* before operating or servicing the plow.
- Ensure that only trained personnel install and perform maintenance on the equipment.
- Keep your hands, feet, and clothing away from moving parts and mounting points.
- Ensure the plow is properly attached to the machine before moving it.

## Operation

- When transporting the machine, position the plow so as not to block your vision.
- **Do not** change the blade position when traveling.
- Always lower the blade when the machine is not in use.
- **Never** put any part of your body between the plow and the machine.
- Do not operate the machine while ill, tired, or under the influence of alcohol or drugs.
- Do not use the plow for any purpose other than plowing snow.
- **Never** ride or lift persons on the plow.
- Do not operate the plow on a steep incline.
- **Always** keep both hands on the handlebars while operating the machine and plow.

## Safety and Instructional Decals



Safety decals and instructions are easily visible to the operator and are located near any area of potential danger. Replace any decal that is damaged or missing.



MSC23037

decalmsc23037

1. Warning—read the *Owner's Manual*.
2. Warning—all operators should be trained before operating the machine.
3. Warning—coupler must be locked before plowing.
4. Warning—coupler must be unlocked to remove the plow.
5. Warning—shut off the engine, remove the key, and read the *Owner's Manual* before performing maintenance.
6. Crushing hazard—do not stand between the plow and vehicle during maintenance.
7. Warning—do not exceed 8 km/h (5 mph) when plowing.
8. Warning—lower the plow when the vehicle is not in use.

# Setup

## Installing the Trip Stops and Urethane Blade

1. Attach the trip stops to the blade using 2 hex-head bolts (5/8–11 x 3 inches) and 2 nylon locknuts (5/8–11 x 3 inches) as shown in [Figure 2](#).

**Important:** Do not overtighten the bolts and nuts; ensure that the trip stops can pivot freely.

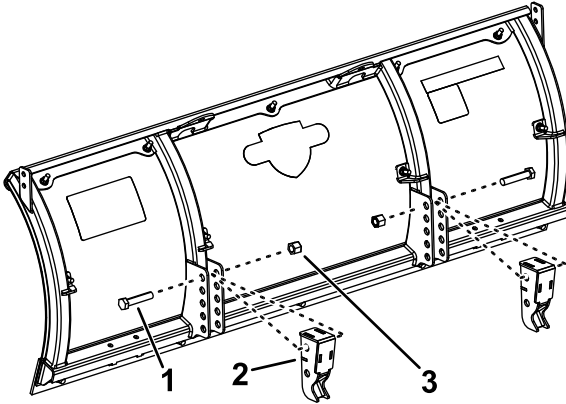

Figure 2

g334229

1. Bolt (5/8–11 x 3 inches)
2. Trip stop
3. Nylon locknut (5/8–11 x 3 inches)

2. Remove and discard the bolts, washers, and nuts securing the steel cutting edge to the bottom of the plow. Discard the cutting edge.
3. Secure the metal strap and urethane blade to the plow using 5 carriage bolts (1/2 inch), 5 washers (1/2 inch), and 5 top locknuts ([Figure 3](#)).

**Note:** Do not tighten the bolts and locknuts at this time.

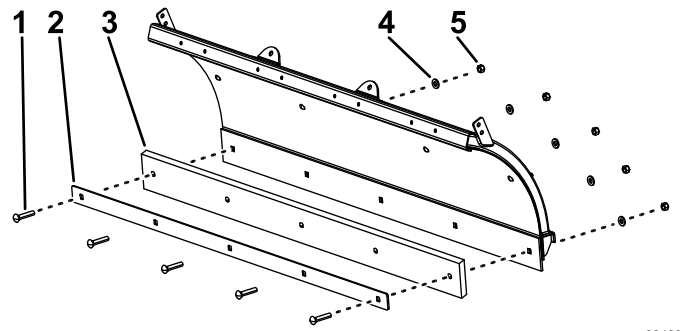

Figure 3

g334230

1. Carriage bolt (1/2 inch)
2. Metal strap
3. Urethane blade
4. Washer (1/2 inch)
5. Top locknut

4. Slide the urethane blade so that it is flush with the sides of the plow.
5. Tighten the bolts until the rubber begins to squish.

## Installing the Push Frame

1. Attach the push frame to the plow using 2 bolts (5/8–11 x 3-1/2 inches) and 2 nylon locknuts (5/8 inch) as shown in [Figure 4](#).

**Important:** Do not overtighten the bolts and nuts; ensure that the push frame can pivot freely.

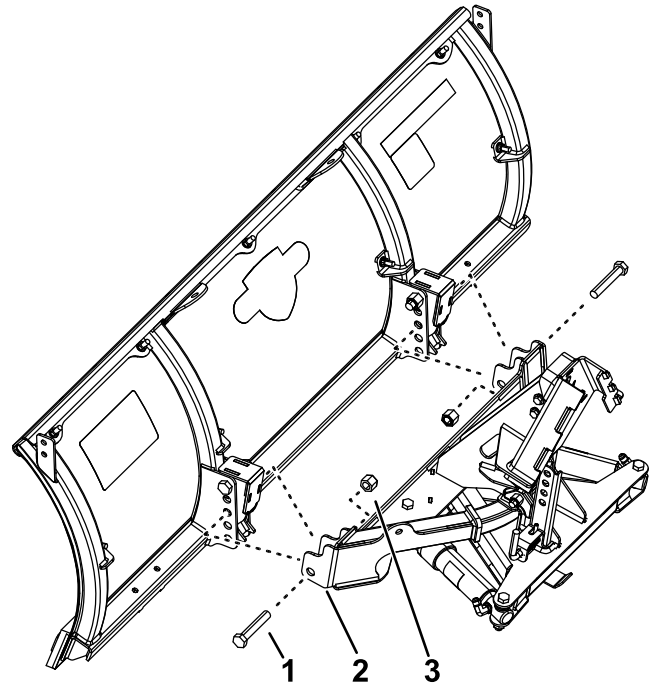

Figure 4

g334231

1. Bolt (5/8–11 x 3-1/2 inches)
2. Push frame
3. Nylon locknut (5/8 inch)

- Hook the 2 trip springs through the holes on the push frame (Figure 5).

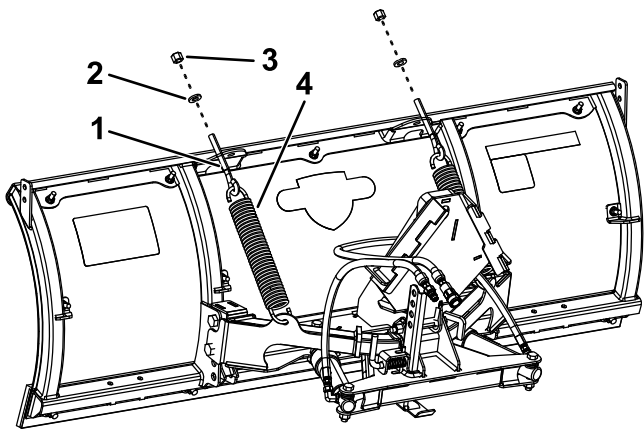

Figure 5

g334232

- |                      |                             |
|----------------------|-----------------------------|
| 1. Eyebolt           | 3. Nylon locknut (1/2 inch) |
| 2. Washer (1/2 inch) | 4. Trip spring              |

- Hook the other ends of the trip springs to 2 eyebolts (Figure 5).
- Insert the threaded end of the eyebolts through the holes on the plow blade and secure them using 2 washers (1/2 inch) and 2 nylon locknuts (Figure 5).
- Tighten the nylon locknuts until there is a gap of 0.8 mm (1/32 inch) between the trip spring coils.
- Loosely attach the pin channel to the push frame using 4 bolts (3/8 inch), 8 washers (3/8 inch), and 4 nylon locknuts (3/8 inch) as shown in Figure 6.

**Note:** Do not tighten the bolts and nuts.

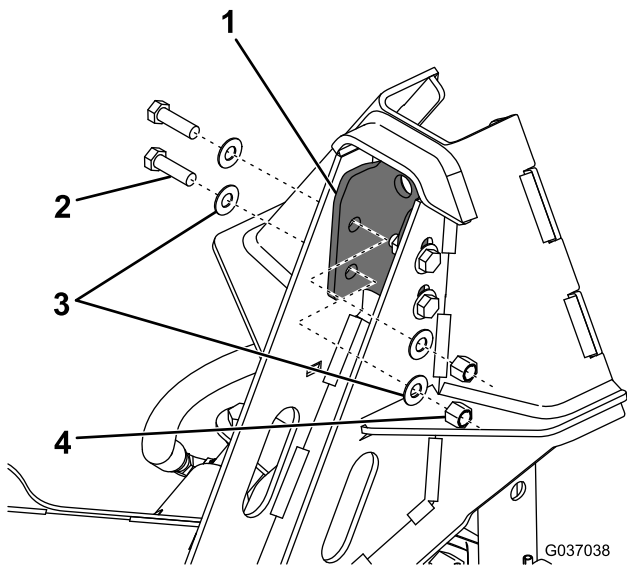

Figure 6

G037038

g037038

- |                    |                             |
|--------------------|-----------------------------|
| 1. Pin channel     | 3. Washers (3/8 inch)       |
| 2. Bolt (3/8 inch) | 4. Nylon locknut (3/8 inch) |

## Mounting the Plow

**Note:** You must first install the Grandstand Low Flow Hydraulic and Quick Attach kits before mounting the plow.

- Ensure that the plow is sitting upright, with the kickstand lowered (Figure 7).

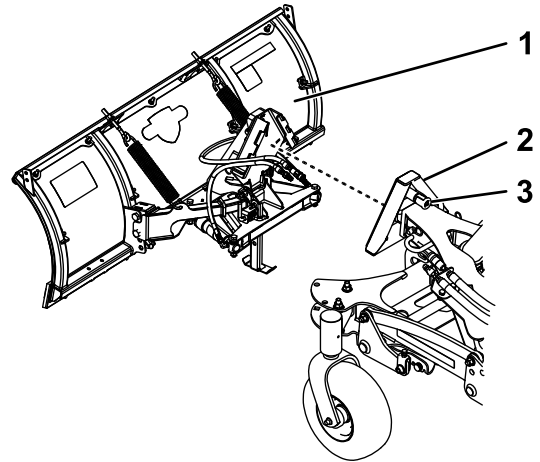

Figure 7

g334233

- |                    |                |
|--------------------|----------------|
| 1. Plow coupler    | 3. Coupler pin |
| 2. A-frame coupler |                |

- Lower the A-frame on the machine completely; refer to Controls (page 7).
- Slowly drive forward until the A-frame coupler contacts the plow coupler (Figure 7).
- Raise the A-frame until the coupler pin locks into place (Figure 8).

**Note:** Ensure that the coupler pin also inserts through the hole in the pin channel on the plow coupler (Figure 8).

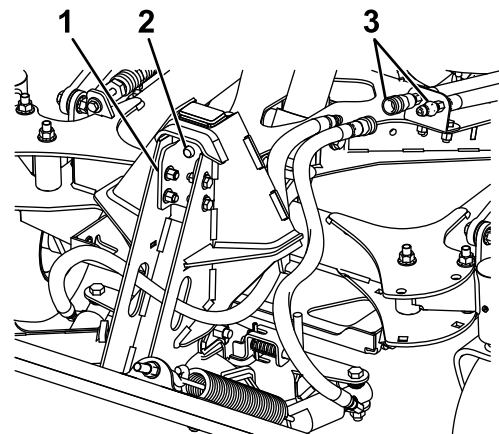

Figure 8

g244392

- |                |                      |
|----------------|----------------------|
| 1. Pin channel | 3. Quick disconnects |
| 2. Coupler pin |                      |

- Moving back and forth between bolts, secure the pin channel in place by torquing the bolts to 42 N·m (31 ft-lb).

**Note:** Ensure that the pin slides easily in and out.

- Lower the A-frame until the plow rests on the ground.
- Shut off the machine engine, wait for all moving parts to stop, engage the parking brake, and remove the key.
- Connect the angle-cylinder hydraulic hoses to the quick disconnects on the machine (Figure 8).
- Raise the kickstand.
- Start the machine.
- Use the controls to move the plow in all directions to cycle the hydraulic fluid.

**Note:** If the blade hoses contact the plow frame, adjust the 90° fittings upward.

- With the hydraulic cylinder fully extended, shut off the engine and wait for all moving parts to stop.
- Clean the area around the cap and the filler neck of the hydraulic tank (Figure 9).

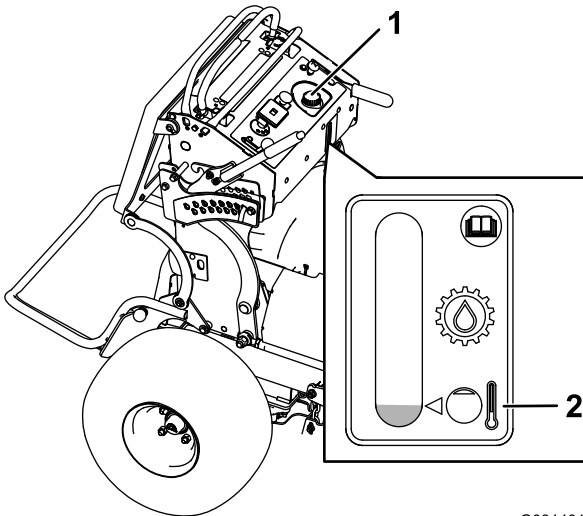

**Figure 9**

- Hydraulic-tank cap
- Fill level

- Remove the cap from the filler neck, and add fluid to the reservoir until it reaches the fill level (Figure 9).

**Important:** Do not use standard BOSS hydraulic fluid in this system. Refer to your Grandstand Multi Force Operator's Manual for the appropriate hydraulic fluid.

**Note:** The fluid level should be at the full mark with the lift cylinder fully extended.

- Install the cap on the filler neck.
- Repeat steps 11 through 15 until all of the hydraulic cylinders extend and retract smoothly.

**Note:** If the hydraulic cylinders do not extend and retract smoothly, there is still air in the hydraulic lines.

### **⚠ WARNING**

**Hydraulic fluid escaping under pressure can penetrate skin and cause injury.**

- If hydraulic fluid is injected into the skin, it must be surgically removed within a few hours by a doctor familiar with this type of injury. Gangrene may result if this is not done.
- Keep your body and hands away from pinhole leaks or nozzles that eject high-pressure hydraulic fluid.
- Use cardboard or paper to find hydraulic leaks.
- Safely relieve all pressure in the hydraulic system before performing any work on the hydraulic system.
- Make sure that all hydraulic-fluid hoses are in good condition, and all that the hydraulic connections and fittings are tight before applying pressure to the hydraulic system.

# Product Overview

## Controls

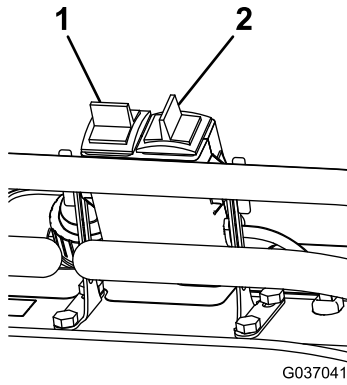

Figure 10

1. A-frame switch
2. Angle switch

- Move the left switch up or down to raise or lower the plow.
- Move the right switch left or right to angle the plow.

## Kickstand

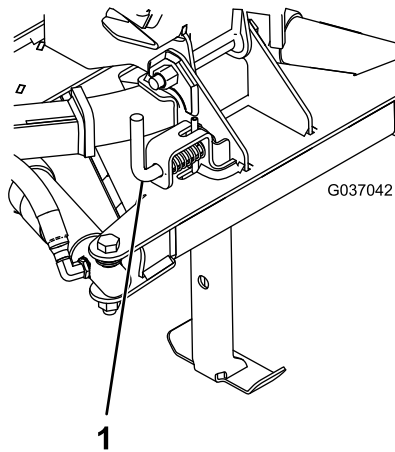

Figure 11

1. Kickstand spring pin

The kickstand keeps the plow upright for ease of mounting and storage. To raise or lower the kickstand, pull the kickstand spring pin and move the kickstand to the desired position. Release the spring pin to lock the kickstand in place.

# Operation

## Mounting the Plow

**Note:** You must first install the Grandstand Low Flow Hydraulic and Quick Attach kits before mounting the plow.

1. Ensure that the plow is sitting upright, with the kickstand lowered (Figure 12).

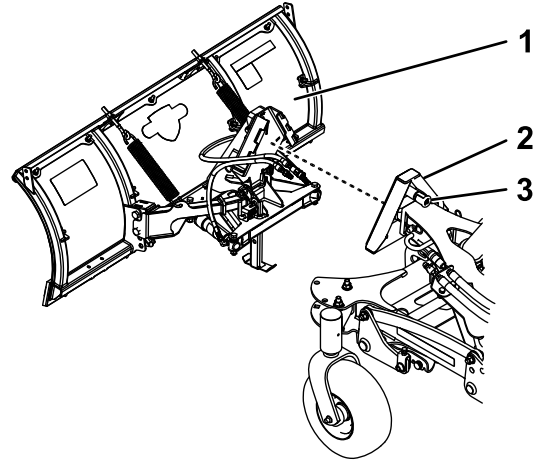

Figure 12

1. Plow coupler
2. A-frame coupler
3. Coupler pin

2. Lower the A-frame on the machine completely; refer to [Controls](#) (page 7).
3. Slowly drive forward until the A-frame coupler contacts the plow coupler (Figure 12).
4. Raise the A-frame until the coupler pin locks into place (Figure 12).
5. Lower the A-frame until the plow rests on the ground.
6. Shut off the machine engine, wait for all moving parts to stop, engage the parking brake, and remove the key.
7. Connect the angle-cylinder hydraulic hoses to the quick disconnects on the machine (Figure 12).
8. Raise the kickstand.
9. Start the machine and use the controls to move the plow in all directions to ensure that the plow is functioning normally.

## Removing the Plow

1. Park the machine on a level surface, shut off the engine, wait for all moving parts to stop, engage the parking brake, and remove the key.

2. Disconnect the angle-cylinder hydraulic hoses from the quick disconnect and attach them to each other (Figure 13).

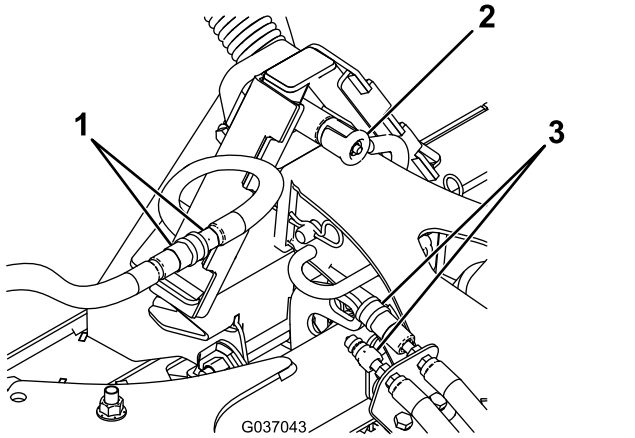

**Figure 13**

1. Plow hoses
2. Coupler pin
3. Quick disconnects

- 
3. Pull the coupler pin to release the couplers (Figure 13).
  4. Start the machine and raise the plow until the kickstand can be lowered all the way.
  5. Lower the kickstand; refer to [Kickstand \(page 7\)](#).
  6. Lower the A-frame until the couplers disconnect.
  7. Slowly back away from the plow.

## Operating Tips

- Become familiar with the area you are plowing; hidden obstructions such as curbs and pipes can damage your plow or machine.
- Do not let snow accumulate; always plow with the storm.
- Lower the plow when not in use to prevent possible injury.
- Always plow at a safe speed in case you hit hidden obstructions.
- When transporting the machine, do not block your vision with the plow.
- Do not change the plow position while plowing.
- Ensure that the kickstand is raised before plowing to prevent damage to the plow or machine.
- For more plowing tips, visit [www.bossplow.com](http://www.bossplow.com).



# Maintenance

## Recommended Maintenance Schedule(s)

Maintenance Service Interval	Maintenance Procedure
After the first 2 hours	<ul style="list-style-type: none"> <li>Tighten all hardware.</li> </ul>
Before each use or daily	<ul style="list-style-type: none"> <li>Check the hydraulic cylinders.</li> <li>Check the hydraulic lines and hoses.</li> <li>Check the hydraulic-fluid level; refer to your Grandstand Multi Force <i>Operator's Manual</i>.</li> <li>Check the wire harness connectors.</li> <li>All fasteners, pins, retainers, nuts, and bolts.</li> <li>Check the cutting edge for wear.</li> </ul>
Before storage	<ul style="list-style-type: none"> <li>Grease the hydraulic cylinder rods.</li> </ul>
Monthly	<ul style="list-style-type: none"> <li>Apply dielectric grease to the wire harness connectors (during plowing season).</li> </ul>
Yearly	<ul style="list-style-type: none"> <li>Replace the hydraulic fluid; refer to your Grandstand Multi Force <i>Operator's Manual</i>.</li> </ul>

## Maintenance

- Check the hydraulic lines and hoses daily for leaks, kinked lines, loose mounting supports, wear, loose fittings, weather deterioration, and chemical deterioration. Make all necessary repairs before operating.
- Check the hydraulic cylinders daily for leaks, rust, or pitting on the rods. Make all necessary repairs before operating.
- Check the wire harness connectors daily for corrosion and damage.
- Apply dielectric grease to the wire harness connectors monthly, during plowing season.
- Check the cutting edge daily for wear. If the cutting edge is worn down either flip or replace it; refer to [Flipping or Replacing the Cutting Edge \(page 9\)](#).
- Check all fasteners, pins, retainers, nuts, and bolts daily to ensure that they are secure. Torque them to the appropriate value if they are loose.

## Flipping or Replacing the Cutting Edge

The urethane cutting edge wears down over time, but can be flipped for extended use. Once the cutting edge has been worn down past the logo, it must be flipped ([Figure 14](#)). If the cutting edge has already been flipped, replace the cutting edge; contact an authorized BOSS dealer for more information.

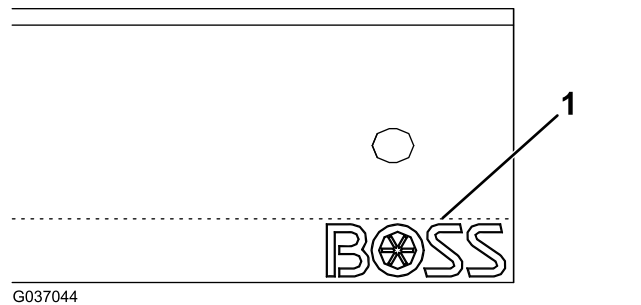
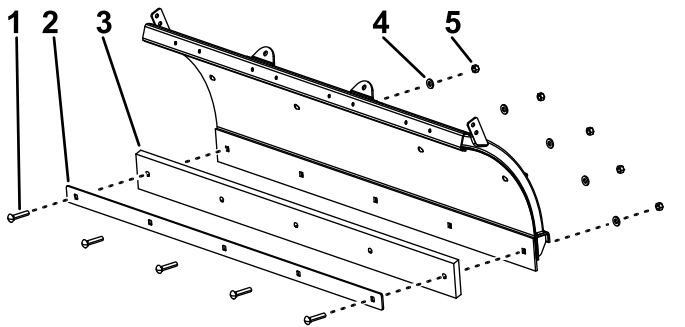

**Figure 14**

1. Wear line

1. Remove the bolts, washers, top locknuts, and metal strap securing the urethane cutting edge to the bottom of the plow.
  2. Flip the cutting edge over.
- Note:** If the cutting edge has already been flipped, discard it and use a new edge.
3. Secure the metal strap and cutting blade to the plow using the previously removed hardware ([Figure 15](#)).

**Note:** Do not tighten the bolts and locknuts at this time.



**Figure 15**

g334230

- |                             |                      |
|-----------------------------|----------------------|
| 1. Carriage bolt (1/2 inch) | 4. Washer (1/2 inch) |
| 2. Metal strap              | 5. Top locknut       |
| 3. Urethane blade           |                      |

- 
4. Slide the cutting blade so that it is flush with the sides of the plow.
  5. Tighten the bolts until the rubber begins to squish.

# Storage

## Storing the Plow

1. Drive the plow to your storage location and remove the plow; refer to [Removing the Plow \(page 7\)](#).
2. Grease any exposed metal on the hydraulic cylinders.
3. Lightly sand and use touch-up paint on painted areas that are scratched, chipped, or rusted.
4. Loosen the trip springs.

## Removing the Plow from Storage

1. Check the torque of all fasteners, pins, retainers, nuts, and bolts; tighten as necessary.
2. Check the hydraulic lines and hoses for cracks or leaks.
3. Check the hydraulic fluid level; refer to your Grandstand Multi Force *Operator's Manual*.
4. Check the cutting edge for wear.
5. Tighten the trip springs.
6. Lightly sand and use touch-up paint on painted areas that are scratched, chipped, or rusted.
7. Attach the plow to the machine; refer to [Mounting the Plow \(page 7\)](#).
8. Move the plow through its range of motion to check the hydraulic cylinder rods.

# Troubleshooting

Problem	Possible Cause	Corrective Action
The plow does not lower.	<ol style="list-style-type: none"> <li>1. The hydraulic manifold wires are not connected properly.</li> <li>2. The hydraulic valve or LOWER coil is bad.</li> <li>3. The wire harness is bad.</li> </ol>	<ol style="list-style-type: none"> <li>1. Check the wires on the hydraulic manifold; refer to the hydraulic manifold schematic.</li> <li>2. While lowering the plow, check for voltage between the white and brown wires for the LOWER coil. If voltage is present, replace the LOWER coil or valve.</li> <li>3. While lowering the plow, check for voltage between the white wires on the connectors between the controller and wire harness. If voltage is present, repair or replace the wire harness.</li> </ol>
The plow does not raise.	<ol style="list-style-type: none"> <li>1. The hydraulic manifold wires are not connected properly.</li> <li>2. The hydraulic valve or RAISE coil is bad.</li> <li>3. The wire harness is bad.</li> </ol>	<ol style="list-style-type: none"> <li>1. Check the wires on the hydraulic manifold; refer to the hydraulic manifold schematic.</li> <li>2. While raising the plow, check for voltage between the orange and brown wires for the RAISE coil. If voltage is present, replace the RAISE coil or valve.</li> <li>3. While raising the plow, check for voltage between the orange wires on the connectors between the controller and wire harness. If voltage is present, repair or replace the wire harness.</li> </ol>
The plow angles while plowing.	<ol style="list-style-type: none"> <li>1. The ANGLE LEFT or ANGLE RIGHT valve is bad.</li> <li>2. The pressure relief valve is bad.</li> </ol>	<ol style="list-style-type: none"> <li>1. Check the valves on the hydraulic manifold. If a valve is contaminated, clean or replace it.</li> <li>2. Check the pressure relief valve. If the valve is contaminated, clean or replace it.</li> </ol>
The plow does not angle or angles slowly.	<ol style="list-style-type: none"> <li>1. The hydraulic fluid level is low.</li> <li>2. The hydraulic manifold wires are not connected properly.</li> <li>3. The ANGLE LEFT or ANGLE RIGHT valve is bad.</li> </ol>	<ol style="list-style-type: none"> <li>1. Check the hydraulic fluid level; refer to your Grandstand Multi Force <i>Operator's Manual</i>.</li> <li>2. Check the wires on the hydraulic manifold; refer to the hydraulic manifold schematic.</li> <li>3. Check the valves on the hydraulic manifold. If a valve is contaminated, clean or replace it.</li> </ol>
Oil leaks from the hydraulic cylinders.	<ol style="list-style-type: none"> <li>1. The hose is bad.</li> <li>2. The cylinder is bad.</li> <li>3. The cylinder rod is pitted.</li> </ol>	<ol style="list-style-type: none"> <li>1. Check the hose for leaks. Apply thread locking compound to the connection or replace the hose.</li> <li>2. Replace the cylinder.</li> <li>3. Polish the rod with steel wool.</li> </ol>

# Schematics

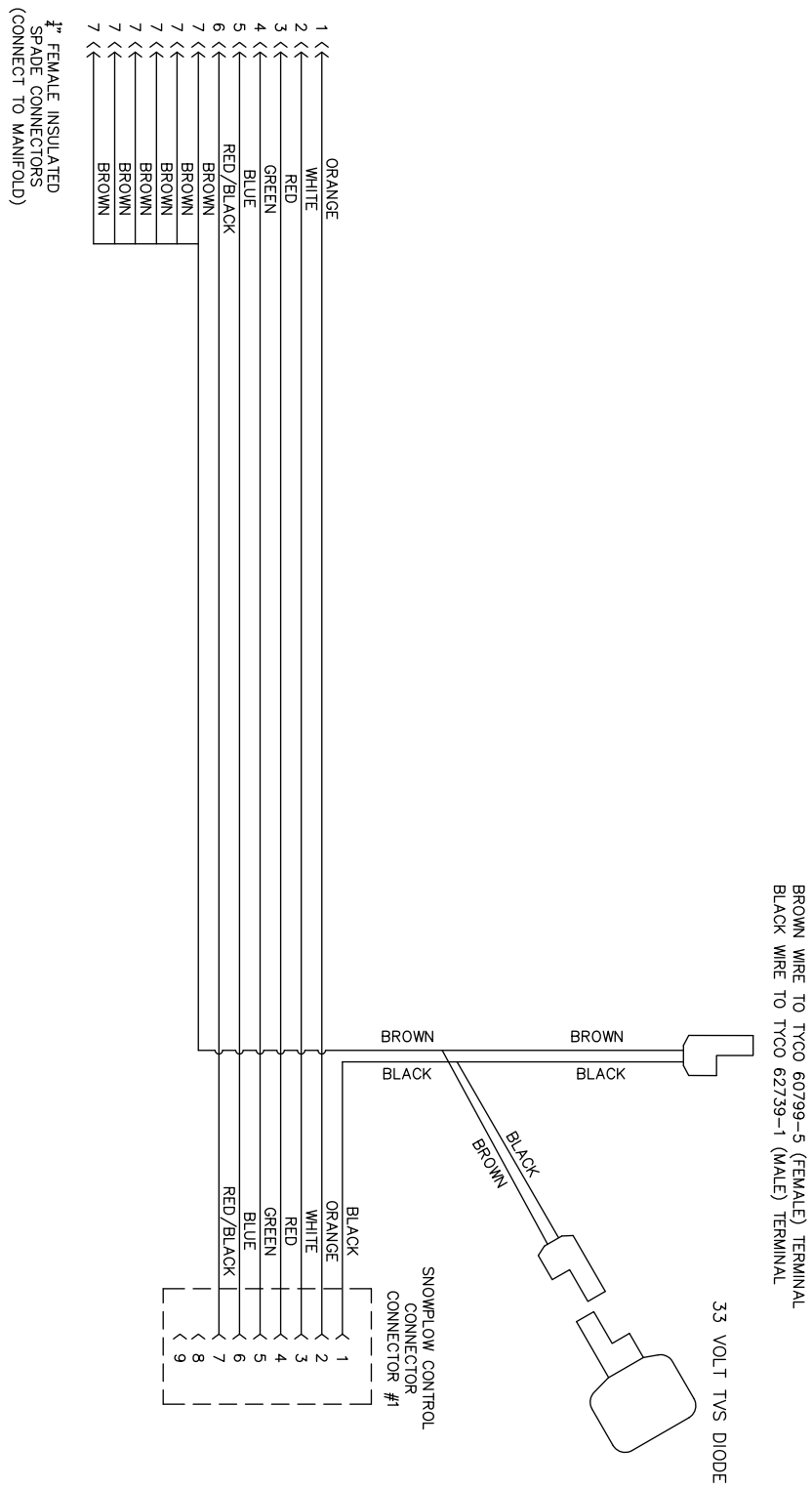

G037075

g037075

Electrical Schematic (Rev. 0)

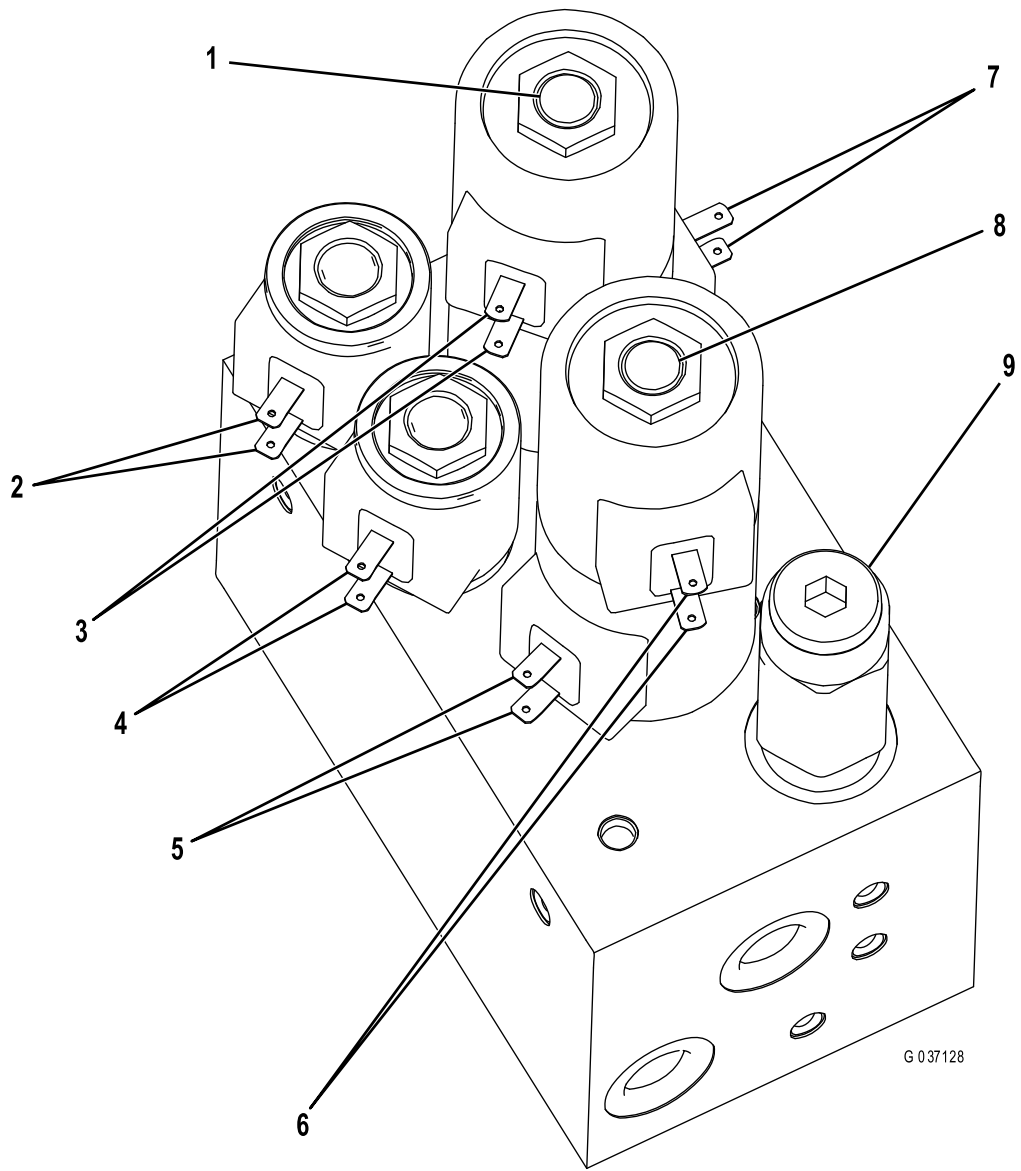

G 037128

g037128

- 1. RAISE/LOWER valve
- 2. Float coil (blue)
- 3. Lower coil (white)
- 4. Float coil (red and black)
- 5. Angle left coil (green)

- 6. Angle right coil (red)
- 7. Raise coil (orange wire)
- 8. ANGLE RIGHT/LEFT valve
- 9. Pressure relief valve

**Hydraulic Manifold (Rev. 0)**

**Notes:**

# BOSS Products Commercial Warranty

**What this warranty covers:**

This warranty covers defects in material and workmanship except as set forth below.

**Who is covered:**

The original purchaser from an authorized dealer.

**For how long:**

**Complete Product:** 2 years from the date of purchase.

**Labor:** 2 years from the date of purchase for complete product.

**Parts:** 1 year from the date of purchase. (no Labor)

**What BOSS Products will do:**

BOSS Products will, at its sole option, repair or replace defective parts at no charge.

**What you must do for warranty service:**

To obtain warranty service, purchaser must return the defective product to any authorized BOSS Products dealer (preferably the one from whom the product was purchased) within the warranty period. Purchaser must be able to verify the original purchase date. All transportation costs to and from the dealer will be the responsibility of the purchaser. To locate the authorized BOSS dealer nearest to you, call toll free: (800) 286-4155.

**What is not covered:**

1. Expendable parts such as hoses, plow shoes, cutting edges, pins, nuts, bolts, blade guides, etc.
2. Products repaired or altered by anyone other than an authorized BOSS Products dealer.
3. Products which have been subject to misuse, negligence, accident, improper installation, maintenance, care, or storage.
4. Products mounted on vehicles other than those listed in the *BOSS Snowplow Application Chart and Selection Guide*.
5. BOSS Products does not assume liability for damage to your motor vehicle resulting from the attachment or use of any BOSS products. Vehicle risk is the sole responsibility of the purchaser.

**Limits of BOSS Products Liability are:**

**BOSS Products' liability is expressly limited to repair or replacement of defective parts. BOSS Products shall not be liable for consequential, incidental, or contingent damages whatsoever, even if damages are caused by the negligence or fault of BOSS Products. The foregoing warranties are exclusive and in lieu of all other express and implied warranties including, but not limited to, the implied warranties of merchantability and fitness for a particular purpose.**

This warranty does not apply if you purchased your product for personal, family, or household use. In this case, refer to the BOSS Products Limited Consumer Warranty.

BOSS Products is a division of  
The Toro® Company  
P.O.Box 787 2010 The BOSS Way  
Iron Mountain, MI 49801

# BOSS Products Consumer Warranty

**What this warranty covers:**

This warranty covers defects in material and workmanship except as set forth below.

**Who is covered:**

The original retail purchaser of a BOSS product who purchases it for personal, family, or household use.

**For how long:**

**Complete Product:** 2 years from the date of purchase.

**Labor:** 2 years from the date of purchase for complete product.

**Parts:** 1 year from the date of purchase. (no Labor)

**What BOSS Products will do:**

BOSS Products will, at its sole option, repair or replace defective parts at no charge.

**What you must do for warranty service:**

To obtain warranty service, purchaser must return the defective product to any authorized BOSS Products dealer (preferably the one from whom the product was purchased) within the warranty period. Purchaser must be able to verify the original purchase date. All transportation costs to and from the dealer will be the responsibility of the purchaser. To locate the authorized BOSS dealer nearest to you, call toll free: (800) 286-4155.

**What is not covered:**

1. Expendable parts such as hoses, plow shoes, cutting edges, pins, nuts, bolts, blade guides, etc.
2. Products repaired or altered by anyone other than an authorized BOSS Products dealer.
3. Products which have been subject to misuse, negligence, accident, improper installation, maintenance, care, or storage.
4. Products mounted on vehicles other than those listed in the *BOSS Snowplow Application Chart and Selection Guide*.
5. BOSS Products does not assume liability for damage to your motor vehicle resulting from the attachment or use of any BOSS products. Vehicle risk is the sole responsibility of the purchaser.

**Limits of BOSS Products Liability are:**

**BOSS Products' liability is expressly limited to repair or replacement of defective parts. BOSS Products shall not be liable for consequential, incidental, or contingent damages whatsoever, even if damages are caused by the negligence or fault of BOSS Products. The foregoing warranties are exclusive and in lieu of all other express and implied warranties including, but not limited to, the implied warranties of merchantability and fitness for a particular purpose.**

**State laws:**

Some states do not allow exclusion of incidental or consequential damages or the limitations on how long an implied warranty lasts, so these limitations or exclusions may not apply to you. This warranty gives you specific legal rights and you may also have the other rights which vary from state to state.

This warranty does not apply if you purchased your product for personal, family, or household use. In this case, refer to the BOSS Products Limited Consumer Warranty.

BOSS Products is a division of  
The Toro® Company  
P.O.Box 787 2010 The BOSS Way  
Iron Mountain, MI 49801