

BOSS Products limited consumer warranty and BOSS Products commercial warranty policies are located at www.BOSSPlow.com.

Patent www.ttcopats.com

Safety

- Always follow the vehicle manufacturer's recommendations relating to system installation. For recommended vehicle models, refer to the *BOSS Snowplow Application Chart and Selection Guide*.
- Never disable, remove, or relocate any sensors or other components related to the operation of the air bags.
- To comply with federal regulations and to assure a safe vehicle, do not exceed the front gross-axle-weight rating (FGAWR), rear gross-axle-weight rating (RGAWR), and the gross-vehicle-weight rating (GVWR) at any time.
- Due to the variety of equipment that you can install on the vehicle and undercarriage, do not exceed the front gross-axle-weight rating (FGAWR), rear gross-axle-weight rating (RGAWR), and the gross-vehicle-weight rating (GVWR) at any time. This may require weighing the vehicle and adding ballast as necessary. It may also limit the payload capacity of the vehicle.

Installation

Determine the left and right sides of the machine from the normal operating position.

1. Park the machine on a level surface, shut off the engine, wait for all moving parts to stop, engage the parking brake, and remove the key.
2. Remove the sections of the front bumper.

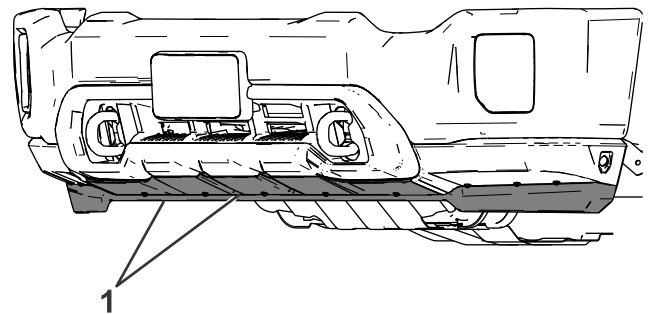

Figure 1

g300479

1. Remove

3. Remove the existing fasteners securing the tow hooks to the vehicle frame.

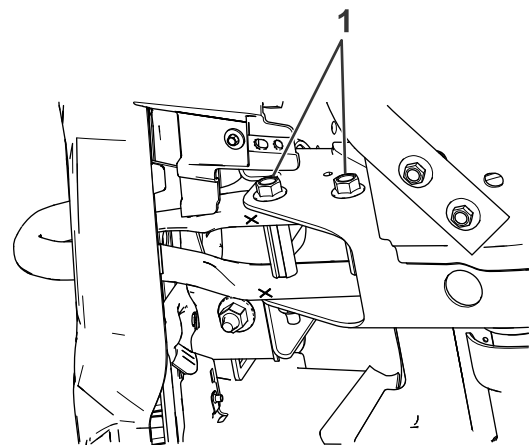

Figure 2

g300480

1. Remove

4. Loosely secure the rear of the undercarriage sideplates to the vehicle frame using a bolt plate, split lockwasher (5/8 inch), and nut.



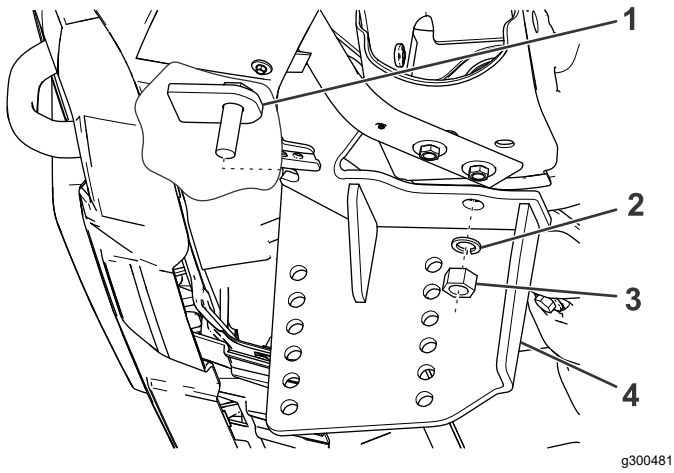

Figure 3

g300481

1. Bolt plate
2. Split lockwasher (5/8 inch)
3. Nut (5/8 inch)
4. Sideplate

5. Loosely secure the front of the undercarriage sideplates to the vehicle frame and tow hooks using 2 bolts (M12), washers (M12), and nylon locknuts.

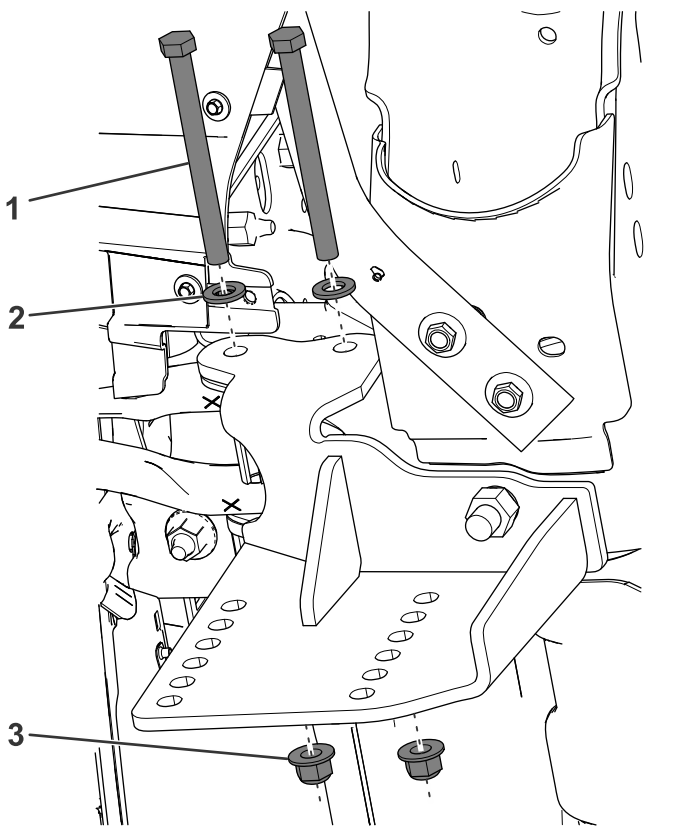

Figure 4

g300482

1. Bolt (M12)
2. Washer (M12)
3. Nylon locknut (M12)

6. Remove the vehicle skid plates.

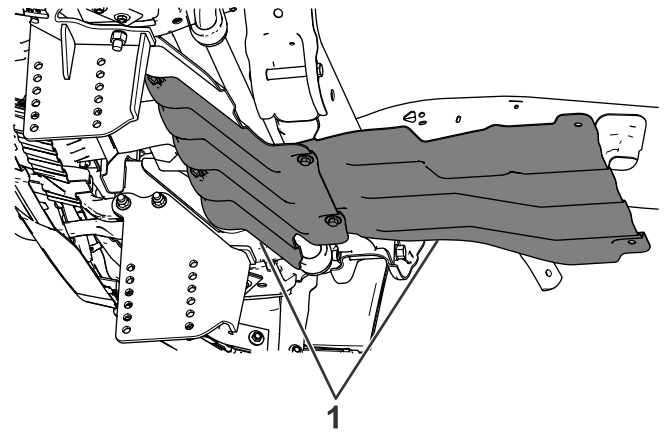

Figure 5

g300483

1. Remove

⚠ WARNING

Using a drill without proper eye protection may allow debris to enter the eye, causing injury.

When drilling, always wear eye protection.

7. Drill the holes in the frame crossbeam larger to 14 mm (9/16 inch).
8. Loosely secure the skid plate bracket to the vehicle frame using 2 bolts (1/2 inch), washers (1/2 inch), split lockwashers (1/2 inch), and full nuts.

Note: Use the bolt puller to position the bolts.

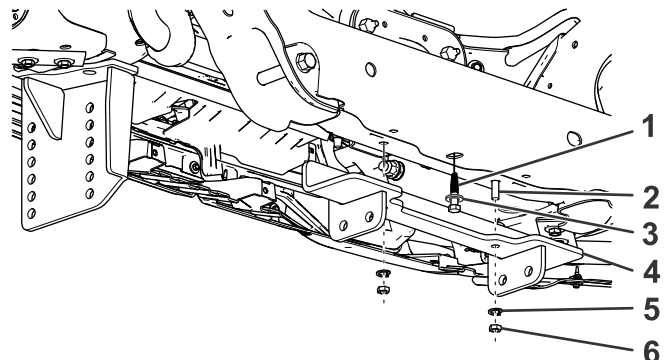

Figure 6

g300484

1. Bolt puller
2. Bolt (1/2 inch)
3. Washer (1/2 inch)
4. Skid plate bracket
5. Split lockwasher (1/2 inch)
6. Full nut (1/2 inch)

9. Loosely secure the pushbeam to the sideplates using 8 bolts (1/2 inch, grade 5) and nylon locknuts (Figure 7).

Note: Refer to your plow *Owner's Manual* for the recommended pushbeam height.

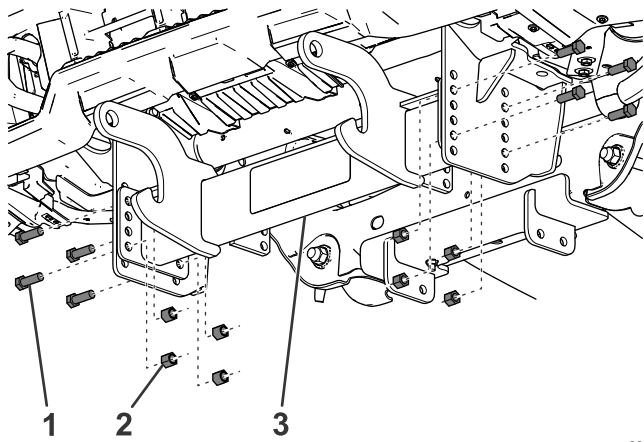

g300485

Figure 7

- | | |
|-----------------------------|-------------|
| 1. Bolt (1/2 inch, grade 5) | 3. Pushbeam |
| 2. Nylon locknut (1/2 inch) | |

10. Loosely secure the front of the angle brackets to the pushbeam using 2 bolts (1/2 inch, grade 8) and nylon locknuts ([Figure 8](#)).

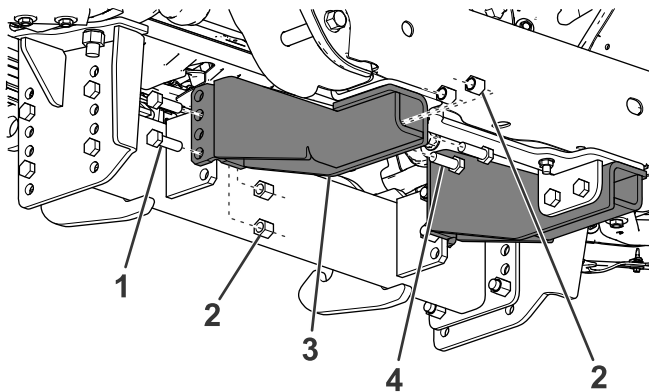

g300486

Figure 8

- | | |
|-----------------------------|-----------------------------|
| 1. Bolt (1/2 inch, grade 8) | 3. Angle bracket |
| 2. Nylon locknut (1/2 inch) | 4. Bolt (1/2 inch, grade 5) |

11. Loosely secure the rear of the angle brackets to the skid plate bracket using 2 bolts (1/2 inch, grade 5) and nylon locknuts ([Figure 8](#)).

12. Torque all the fasteners, in this order, to the following specifications:
- Pushbeam to the sideplates: 76 N·m (56 ft-lb)
 - Front of the sideplates: 96 N·m (71 ft-lb)
 - Rear of the sideplate: 153 N·m (113 ft-lb)
 - Skid plate bracket: 76 N·m (56 ft-lb)
 - Front of the angle brackets: 108 N·m (80 ft-lb)
 - Rear of the angle brackets: 76 N·m (56 ft-lb)

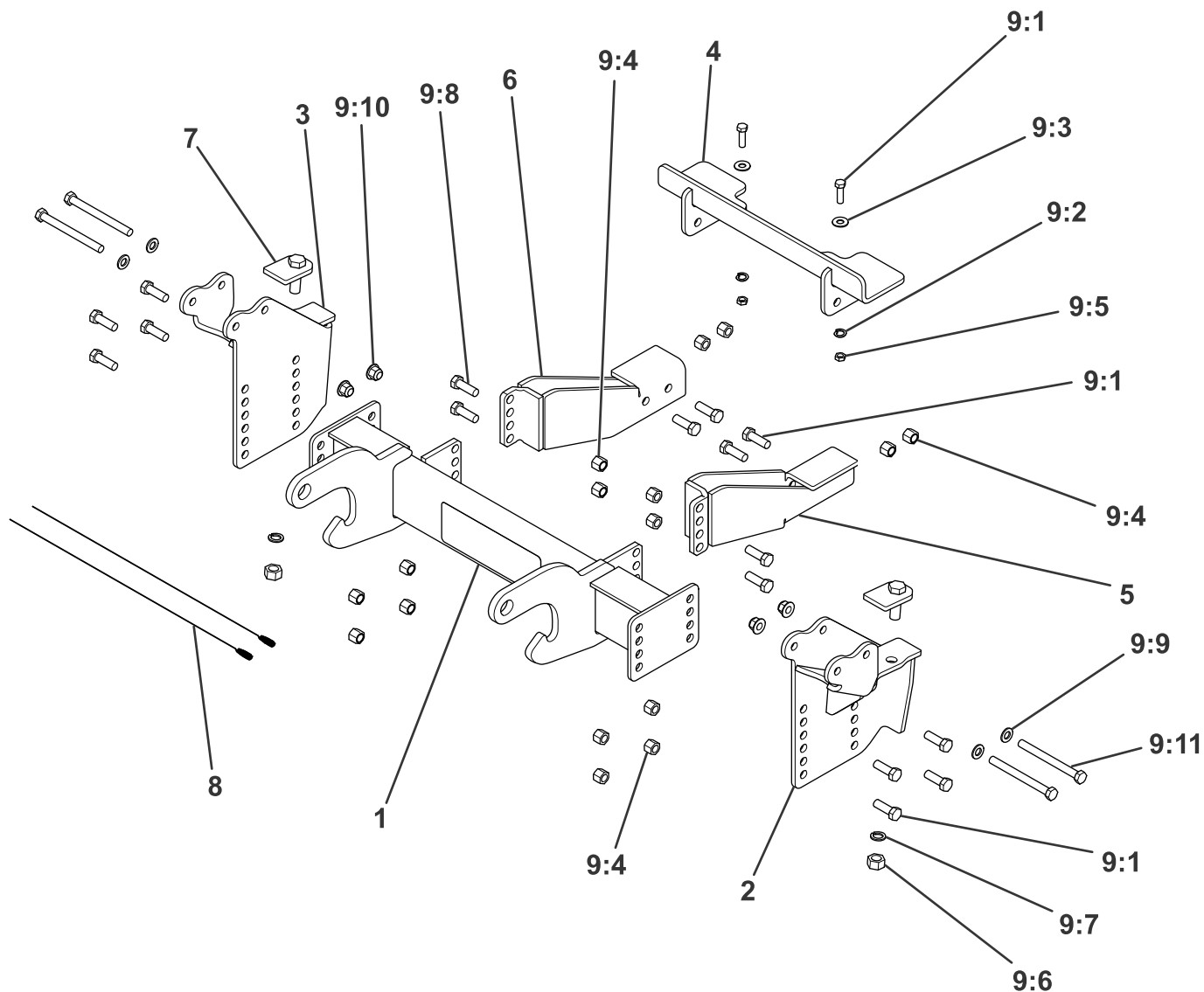

Parts

g359154

Ref.	Part Number	Qty.	Description	Ref.	Part Number	Qty.	Description
1	PBA15355-03	1	PB ASM, GM HD, 20+	9:3	HDW01729	2	WASHER, 1/2, F436 HARD, F/W, YZN
2	PBA15356-03	1	PBSP, DR, GM HD, 20+	9:4	HDW01748	16	NUT, 1/2-13, NYL INS, YZN
3	PBA15357-03	1	PBSP, PS, GM HD, 20+	9:5	HDW02410	2	NUT, 1/2-13, FIN, FULL, YZN
4	LTA15358-03	1	SKID PLT, GM HD, 20+	9:6	HDW01777	2	NUT, 5/8-11, FIN, FULL, YZN
5	LTA15359-03	1	ANG BRKT, DR, GM HD, 20+	9:7	HDW03891	2	WASHER-LOCK, SPLIT, 5/8, YZN
6	LTA15360-03	1	ANG BRKT, PS, GM HD, 20+	9:8	HDW05553	4	HHCS, 1/2-13 X 1-1/2 NC GR8 YZN
7	PBA15377-03	2	BOLT PLATE, GM HD, 20+	9:9	HDW11237	4	WASHER, FLAT, M12, YZN
8	MSC09670	2	BOLT PULLER	9:10	HDW11238	4	NUT, NYLOCK, FLANGE, M12 X 1.75 MM, CL10, YZN
9	HDW15379	1	KIT-FASTENER, GM HD, 20+	9:11	HDW15373	4	HHCS, M12 X 1.75 X 130 MM, CL10.9, YZN
9:1	HDW01728	14	HHCS, 1/2-13 X 1-1/2, NC, GR5, YZN				
9:2	HDW01732	2	WASHER, 1/2, SPLIT LOCK, YZN				