

BOSS Products limited consumer warranty and BOSS Products commercial warranty policies are located at [www.BOSSPlow.com](http://www.BOSSPlow.com).

Patent: [www.ttcopats.com](http://www.ttcopats.com)

## Safety

- Always follow the vehicle manufacturer's recommendations relating to system installation. For recommended vehicle models, refer to the *BOSS Snowplow Application Chart and Selection Guide*.
- Never disable, remove, or relocate any sensors or other components related to the operation of the air bags.
- To comply with federal regulations and to assure a safe vehicle, do not exceed the front gross-axle-weight rating (FGAWR), rear gross-axle-weight rating (RGAWR), and the gross-vehicle-weight rating (GVWR) at any time.
- Due to the variety of equipment that you can install on the vehicle and undercarriage, do not exceed the front gross-axle-weight rating (FGAWR), rear gross-axle-weight rating (RGAWR), and the gross-vehicle-weight rating (GVWR) at any time. This may require weighing the vehicle and adding ballast as necessary. It may also limit the payload capacity of the vehicle.

## Installation

Determine the left and right sides of the machine from the normal operating position.

1. Park the machine on a level surface, shut off the engine, wait for all moving parts to stop, engage the parking brake, and remove the key.
2. Remove or trim the lower vehicle bumper (Figure 1).

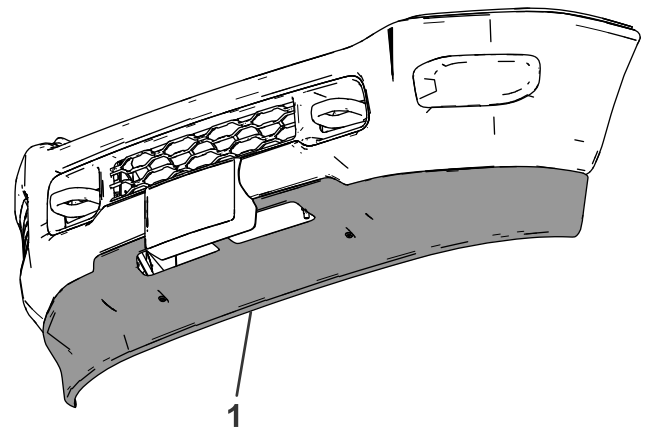

g295432

Figure 1

1. Remove or trim

3. Remove the existing fasteners indicated in Figure 2.



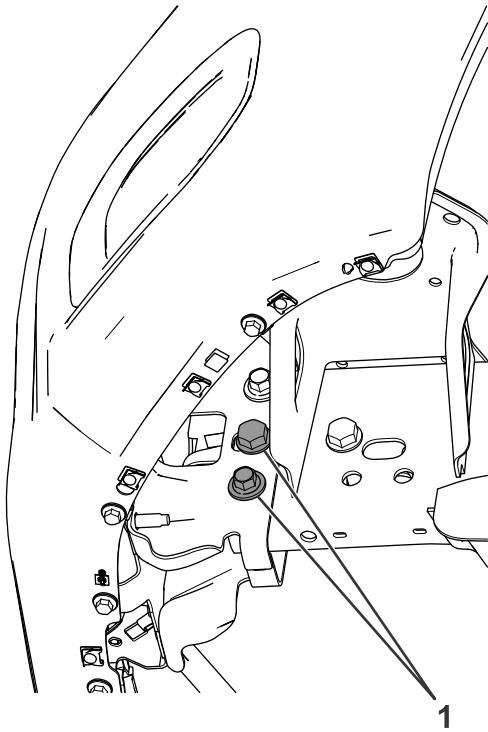
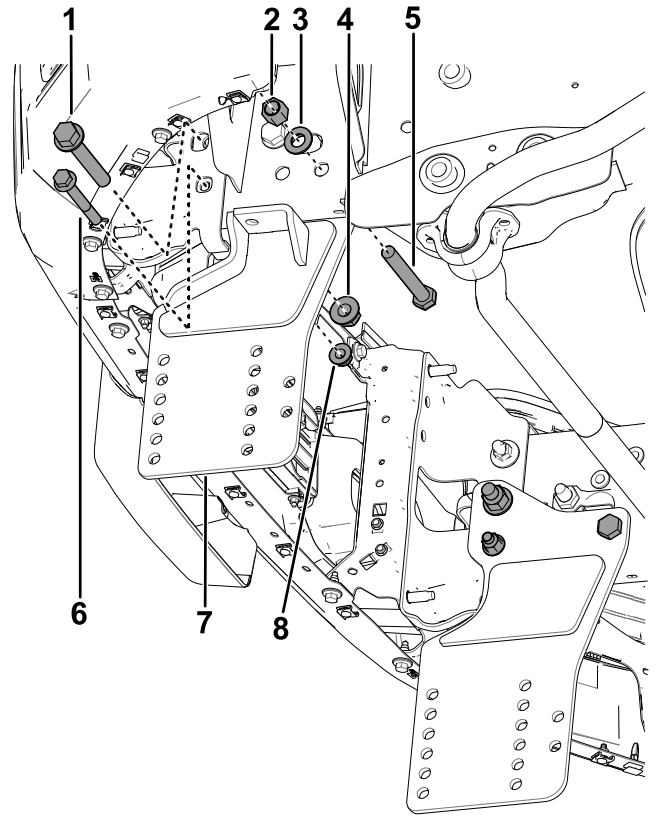

**Figure 2**

g295433

1. Remove

4. Loosely secure the sideplates to the vehicle frame using the fasteners shown in [Figure 3](#).

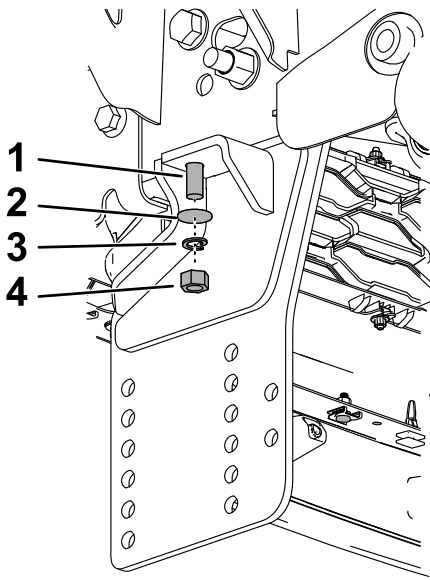

**Figure 3**

g327968

- |                      |                    |
|----------------------|--------------------|
| 1. Bolt (M16)        | 5. Bolt (5/8 inch) |
| 2. Nut (5/8 inch)    | 6. Bolt (M12)      |
| 3. Washer (5/8 inch) | 7. Sideplate       |
| 4. Nut (M16)         | 8. Nut (M12)       |

5. Loosely secure the bottom of the sideplate to the vehicle frame using a bolt (1/2 x 1-1/2 inches), washer, split lockwasher, and nut ([Figure 4](#)).

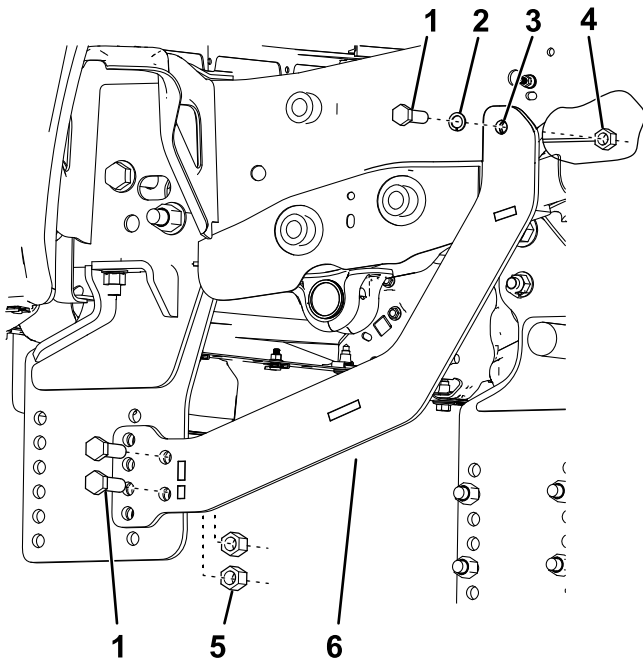

**Figure 4**

g327970

- |                              |                     |
|------------------------------|---------------------|
| 1. Bolt (1/2 x 1-1/2 inches) | 3. Split lockwasher |
| 2. Washer (1/2 inch)         | 4. Nut (1/2 inch)   |

6. Loosely secure the angle brackets to the sideplates using 2 bolts (1/2 x 1-1/2 inches) and nylon locknuts (Figure 5).



**Figure 5**

g327971

- |                              |                             |
|------------------------------|-----------------------------|
| 1. Bolt (1/2 x 1-1/2 inches) | 4. Nut bar                  |
| 2. Split lockwasher          | 5. Nylon locknut (1/2 inch) |
| 3. Drill here.               | 6. Angle bracket            |

7. Using the angle bracket as a guide, mark and drill a hole (9/16 inch) in the outer wall of the vehicle frame rail (Figure 5).
8. Repeat step 7 on the other side of the vehicle.

9. Loosely secure the top of the angle bracket to the vehicle frame using a bolt (1/2 x 1-1/2 inches), split lockwasher, and nut bar (Figure 5).
10. Loosely secure the pushbeam to the sideplate using 4 bolts (1/2 x 1-1/2 inches) and nylon locknuts (Figure 6).

**Note:** Refer to your plow *Owner's Manual* for the appropriate pushbeam height.

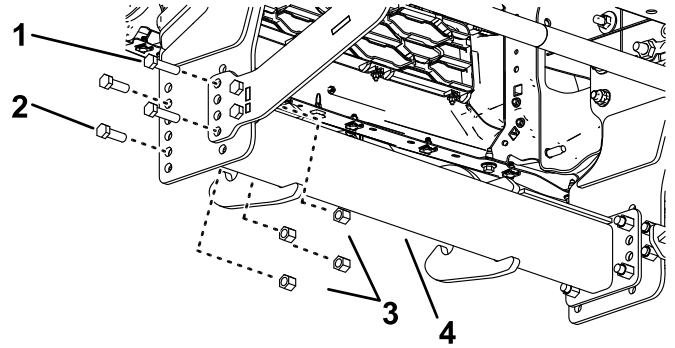
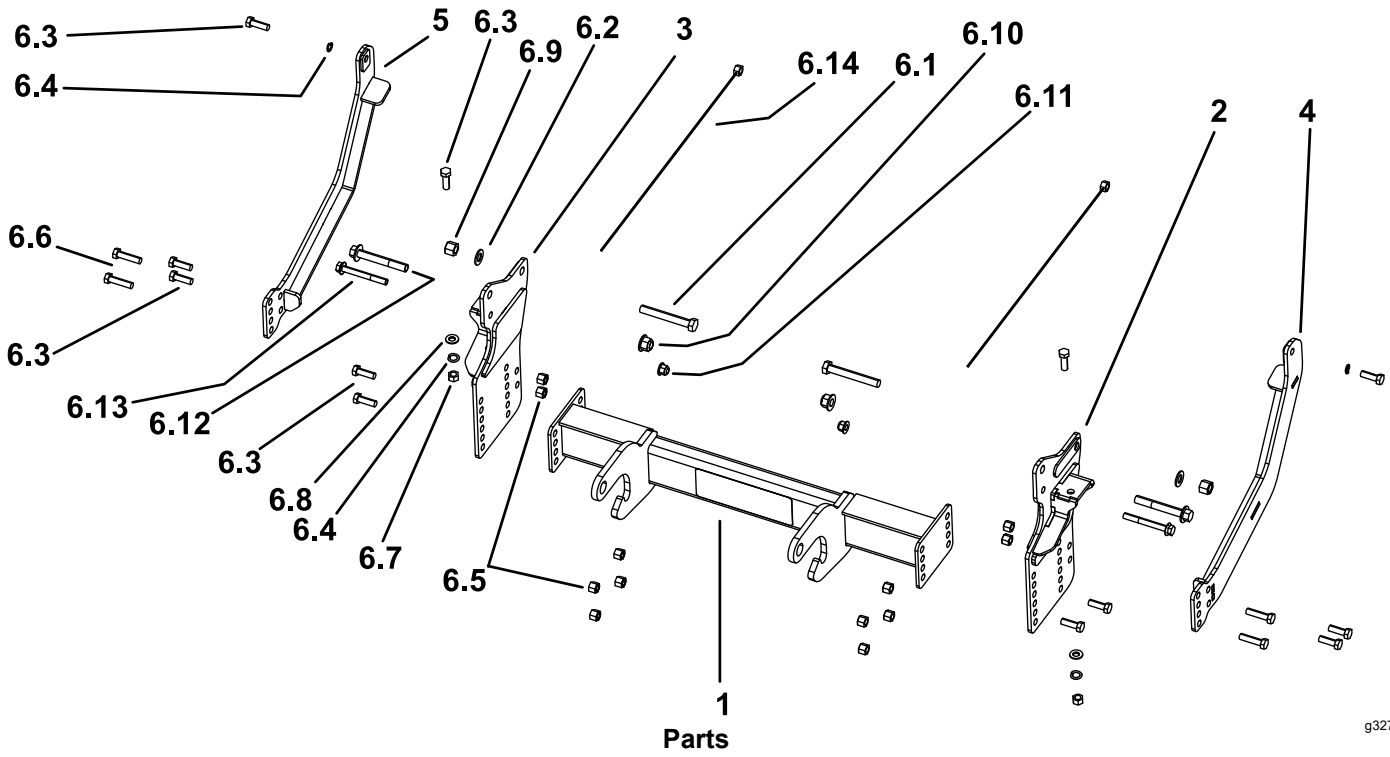

**Figure 6**

g327972

- |                              |                             |
|------------------------------|-----------------------------|
| 1. Bolt (1/2 x 1-1/2 inches) | 3. Nylon locknut (1/2 inch) |
| 2. Bolt (1/2 x 2 inches)     | 4. Pushbeam                 |

11. Loosely secure the pushbeam to the angle bracket and sideplates using 4 bolts (1/2 x 2 inches) and nylon locknuts (Figure 6).
12. Torque the fasteners to the following specifications:
- 1/2-inch bolts to 76 N·m (56 ft-lb)
  - 5/8-inch bolts to 153 N·m (113 ft-lb)
  - M12 bolts to 96 N·m (71 ft-lb)
  - M16 bolts to 257 N·m (190 ft-lb)



g327969

Ref.	Part Number	Qty.	Description	Ref.	Part Number	Qty.	Description
1	PBA15405-03	1	PB ASM, RAM 2500/3500, 19+	6:5	HDW01748	12	NUT, 1/2-13, NYL INS, YZN
2	PBA15470-03	1	PBSP,DR, RAM 2500/3500, 19+	6:6	HDW01755	4	HHCS, 1/2-13 X 2, GR5, YZN
3	PBA15475-03	1	PBSP,PS, RAM 2500/3500, 19+	6:7	HDW02410	2	NUT, 1/2-13, FIN, FULL, YZN
4	LTA15471-03	1	ANG BRKT,DR, RAM 2500/3500, 19+	6:8	HDW05501	2	WASHER, FLAT, 1/2, YZN
5	LTA15476-03	1	ANG BRKT,PS, RAM 2500/3500, 19+	6:9	HDW05619	2	NUT, 5/8-11, NYL INS, YZN
6	HDW15423	1	KIT-FASTENER, RAM 2500/3500, 19+	6:10	HDW10399	2	NUT, NYLOCK, M16, 10.9, FLANGE HEAD, YZN
6:1	HDW01705	2	HHCS, 5/8-11 X 4-1/2 NC, GR5, YZN	6:11	HDW11238	2	NUT, NYLOCK, FLANGE, M12 X 1.75 MM, CL10, YZN
6:2	HDW01726	2	WASHER, 5/8 FLAT HARDEN YZN	6:12	HDW15422	2	HHCS, M16 X 110 MM, 10.9, FLANGE HEAD, YZN
6:3	HDW01728	12	HHCS, 1/2-13 X 1-1/2, NC, GR5, YZN	6:13	HDW15428	2	HHCS, M12 X 1.75 MM X 100 MM, CL10.9, FLNGE, YZN
6:4	HDW01732	4	WASHER, 1/2, SPLIT LOCK, YZN	6:14	LTA05391	2	NUT BAR, 1/2-13 x 24