

BOSS Products limited consumer warranty and BOSS Products commercial warranty policies are located at www.BOSSPlow.com.

Safety

- Always follow the vehicle manufacturer's recommendations relating to system installation. For recommended vehicle models, refer to the *BOSS Snowplow Application Chart and Selection Guide*.
- Never disable, remove, or relocate any sensors or other components related to the operation of the air bags.
- To comply with federal regulations and to assure a safe vehicle, do not exceed the

front gross-axle-weight rating (FGAWR), rear gross-axle-weight rating (RGAWR), and the gross-vehicle-weight rating (GVWR) at any time.

- Due to the variety of equipment that you can install on the vehicle and undercarriage, do not exceed the front gross-axle-weight rating (FGAWR), rear gross-axle-weight rating (RGAWR), and the gross-vehicle-weight rating (GVWR) at any time. This may require weighing the vehicle and adding ballast as necessary. It may also limit the payload capacity of the vehicle.

Installation

1. Park the vehicle on a level surface, shut off the engine, and remove the key.
2. Remove the grill to access the bumper mounting bolts.
3. Disconnect any electrical connectors that may prevent bumper removal.
4. Remove the bumper and place it face down on a suitable surface that will not damage the front surface of the bumper.
5. Remove the bolts that fasten the rear brackets to the bumper shell ([Figure 1](#)).

Important: Be careful to remove any sensors or wiring that may be fastened to the bumper shell.

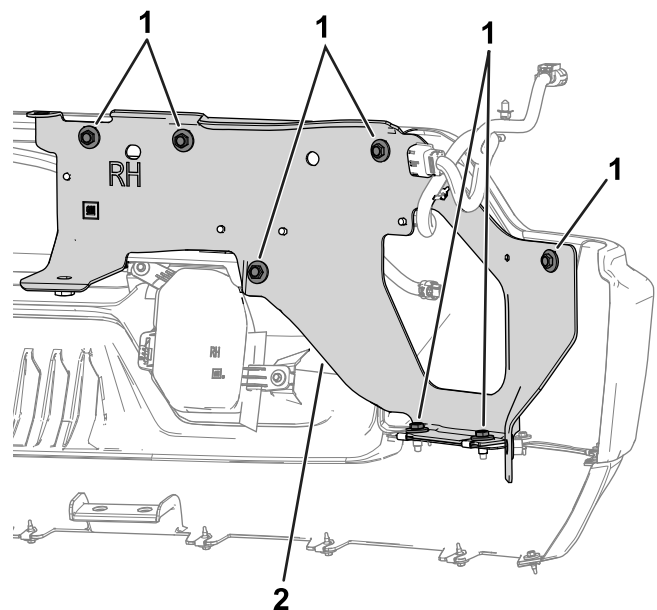

Figure 1

1. Bolt
2. Rear bracket

6. Remove the bolts that secure the existing bumper trim to the bumper.
7. Remove the J-nuts from the existing bumper trim and install them on the new bumper trim.

8. Use existing bolts to secure the new bumper trim to the bumper.
9. Reinstall the rear brackets to the bumper shell and connect any previously-removed sensors, lights, or wiring.

Note: Retain any extra hardware in case of future removal of the new bumper trim.

10. Install the bumper and grill to the vehicle and ensure that the fit and finish is restored to its original condition.

Note: If the existing trim may be installed in the future, save the trim.

Note: If you are installing a license plate, use existing license plate hardware or other appropriately-sized screws.