



P.O. Box 787
Iron Mountain, MI 49801
United States

Owner's Manual

Expanding Wing Drag Pro Rear Mounted Plow

Part No. RPL21600B—Serial No. 400000000 and Up

Part No. RPL21612—Serial No. 400000000 and Up

Part No. RPL21616—Serial No. 400000000 and Up

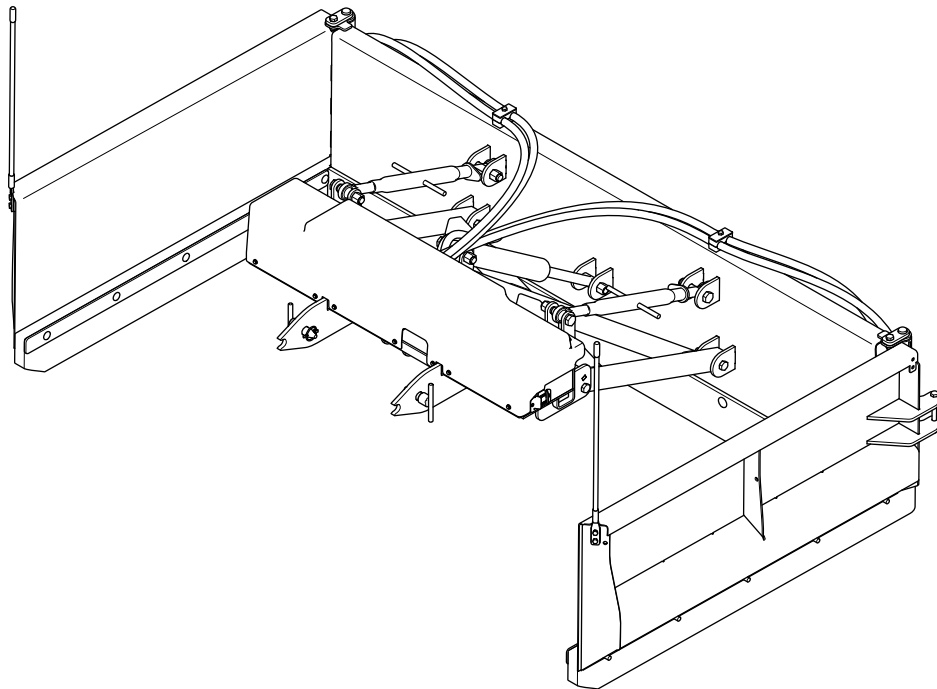

This product complies with all relevant European directives; for details, please see the separate product specific Declaration of Conformity (DOC) sheet.

BOSS Products limited consumer warranty and BOSS Products commercial warranty policies are located at www.BOSSPlow.com.

Patents pending.

Introduction

Note: This manual is used for the assembly, operation, and maintenance of the BOSS expanding wing rear mounted plows. Illustrations may vary.

Read this information carefully to learn how to operate and maintain your product properly and to avoid injury and product damage. You are responsible for operating the product properly and safely.

Visit www.BOSSPlow.com for product safety and operation training materials, accessory information, help finding a dealer, or to register your product.

Whenever you need service, genuine BOSS parts, or additional information, contact an Authorized BOSS Dealer or BOSS Technical Service (1-800-286-4155) and have the model and serial numbers of your product ready. [Figure 1](#) and [Figure 2](#) identify the locations of the model and serial numbers on the product. Write the numbers in the space provided.

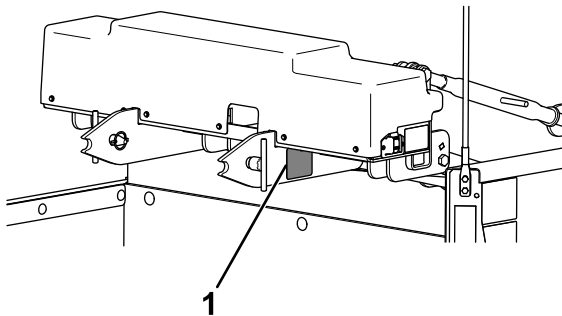

Figure 1

g252243

1. Serial number decal

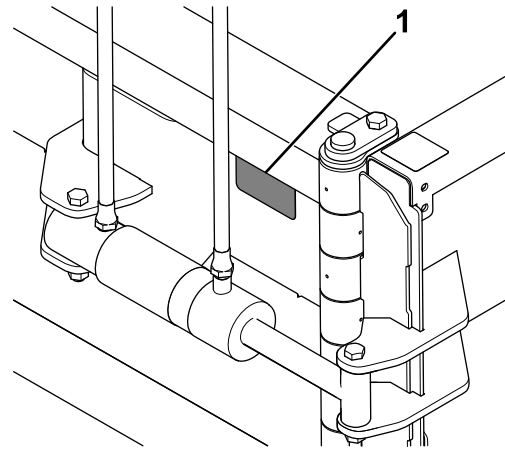

Figure 2

g252244

1. Serial number decal

Date Purchased	_____
Model No.	_____
Serial No.	_____
Blade Crate Serial No.	_____

This manual identifies potential hazards and has safety messages identified by the safety-alert symbol ([Figure 3](#)), which signals a hazard that may cause serious injury or death if you do not follow the recommended precautions.



Figure 3

g000502

1. Safety-alert symbol

This manual uses 2 words to highlight information. **Important** calls attention to special mechanical information and **Note** emphasizes general information worthy of special attention.

Contents

Safety	3
Preparation.....	3
Operation.....	3
Safety and Instructional Decals	4
Setup	7
Installing the Plow Wings	7
Installing the Lift Arm and Top Links	7
Installing the Hydraulic Cylinders	8
Torquing the Fasteners	9
Installing the Hydraulic Hoses.....	9
Installing the Blade Guides and Filling the Hydraulic Reservoir.....	10
Installing the Wire Harness	11
Mounting the Plow Controller	12
Adjusting the Pushbeam Height.....	13
Mounting the Plow	13
Adjusting the Angle of Attack	13
Product Overview	14
Controls	14
Specifications	15
Attachments/Accessories	15
Before Operation	16
Adjusting the Pushbeam Height.....	16
Mounting the Plow	17
Adjusting the Angle of Attack	17
Checking the Hydraulic Fluid	17
Adding Hydraulic Fluid.....	18
During Operation	18
Plowing.....	18
Protecting Your Transmission	18
Plowing Parking Lots	18
Operating Tips	19
After Operation	19
Removing the Plow.....	19
Maintenance	20
Recommended Maintenance Schedule(s)	20
Draining the Hydraulic Fluid.....	20
Adding Hydraulic Fluid.....	21
Adjusting the Hydraulic Lowering Speed.....	21
Checking the Hydraulic Lines and Hoses.....	21
Storage	22
Storing the Plow	22
Removing the Plow from Storage.....	22
Troubleshooting	23
Schematics	26

Safety

Improper use or maintenance by the operator or owner can result in injury. To reduce the potential for injury, comply with these safety instructions and always pay attention to the safety-alert symbol **▲**, which means **Caution, Warning, or Danger**—personal safety instruction. Failure to comply with the instruction may result in personal injury or death.

Preparation

- Read the *Owner's Manual* before operating or servicing the plow.
- Always follow the vehicle manufacturer's recommendations relating to snowplow installation. For recommended vehicle models, refer to the BOSS product selector tool at www.BOSSPlow.com.
- Ensure that only trained personnel install and perform maintenance on the equipment and hydraulic components.
- Never disable, remove, or relocate any sensors or other components related to the operation of the air bags in your vehicle.
- Keep your hands, feet, and clothing away from moving parts and mounting points.
- Ensure the plow is properly attached to the vehicle before moving it.
- To comply with federal regulations and to assure a safe vehicle, do not exceed the front gross-axle-weight rating (FGAWR), rear gross-axle-weight rating (RGAWR), and the gross-vehicle-weight rating (GVWR) at any time.
- Always wear appropriate personal protective equipment when operating and servicing the machine. Wear substantial, slip-resistant footwear, and cold-weather clothing.
- Use a 500 kg (1/2 ton) minimum lifting device to move heavy plow components.

Operation

- Vehicles equipped with air bags are designed so that the air bags activate in a frontal collision equivalent to hitting a solid barrier (such as a wall) at approximately 22 km/h (14 mph) or more, or a frontal perpendicular collision with a parked car or truck of similar size at approximately 45 km/h (28 mph) or more. Careless or high-speed driving while plowing snow can deploy the air bag.
- Do not change the blade position when traveling.
- Do not exceed 64 km/h (40 mph) when transporting the plow.

- Do not exceed 23 km/h (14 mph) when plowing.
- Always lower the blade when the vehicle is not in use.
- Never put any part of your body between the plow and the vehicle.
- Do not operate the machine while ill, tired, or under the influence of alcohol or drugs.
- Always wear your seat belt while operating a motor vehicle.
- Due to the variety of equipment that you can install on the vehicle, do not exceed the front gross-axle-weight rating (FGAWR), rear gross-axle-weight rating (RGAWR), and the

gross-vehicle-weight rating (GVWR) at any time. This may require weighing the vehicle and adding ballast as necessary. It may also limit the payload capacity of the vehicle.

- This machine has an operating sound level below 70 dBA.
- When transporting the machine, ensure that it is properly secured. Instructions are available at www.BOSSPlow.com.
- Use your full attention while operating the machine. Do not engage in any activity that causes distractions; otherwise, injury or property damage may occur.

Safety and Instructional Decals



Safety decals and instructions are easily visible to the operator and are located near any area of potential danger. Replace any decal that is damaged or missing.



MSC18131

decalmsc18131b

1. Crushing hazard—keep hands clear.

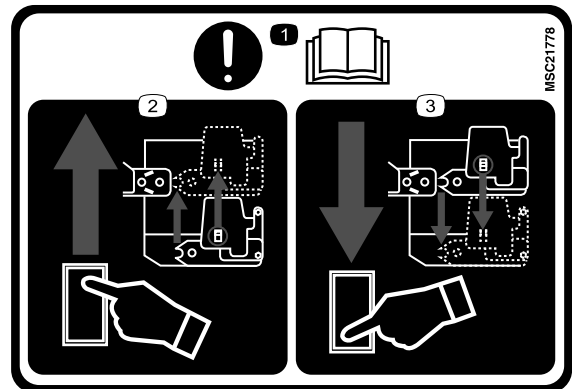

MSC21778

decalmsc21778

1. Attention—read the *Owner's Manual*.
2. Press the switch up to raise the coupler assembly.
3. Press the switch down to lower the coupler assembly.

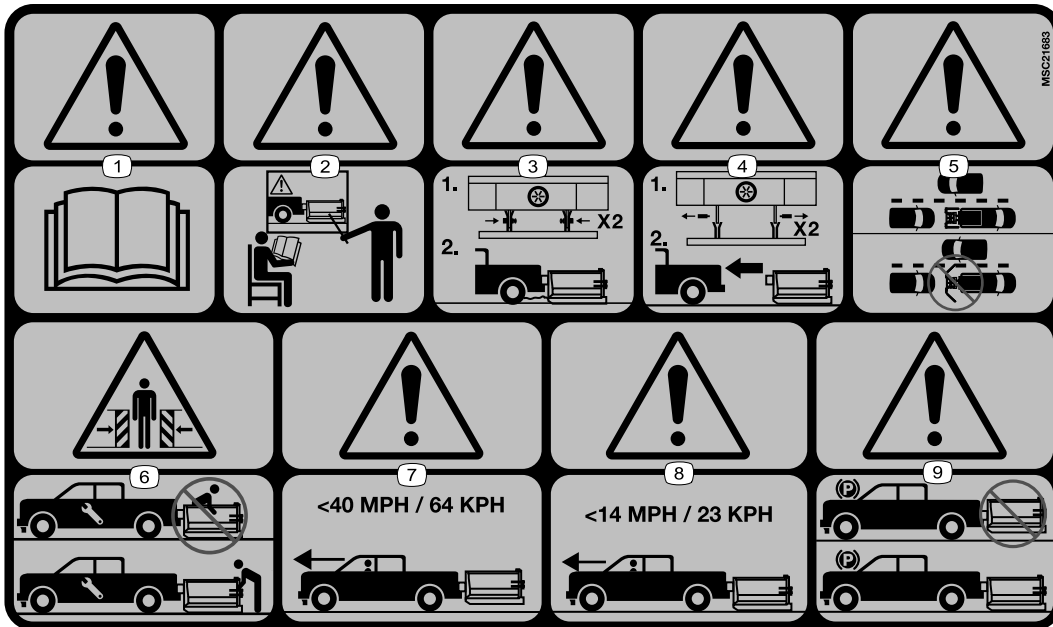

MSC21683

decalmsc21683

1. Warning—read the *Owner's Manual*.
2. Warning—all operators should be trained before operating the machine.
3. Warning—secure the attachment pins before plowing.
4. Warning—attachment pins must be removed to remove the plow.
5. Warning—do not transport the plow with the blade wings extended.
6. Crushing hazard—do not stand between the plow and vehicle during maintenance.
7. Warning—do not exceed 64 km/h (40 mph) when transporting the plow.
8. Warning—do not exceed 23 km/h (14 mph) when plowing.
9. Warning—lower the plow when the vehicle is not in use.

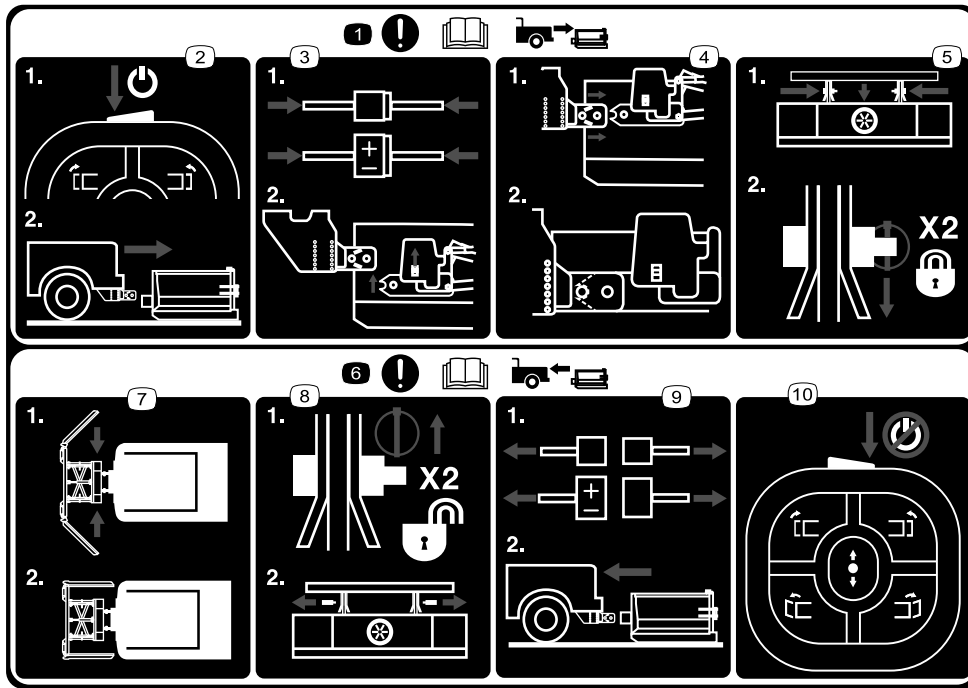

decalmsc21773

MSC21773

1. Attention—read the *Owner's Manual* before attaching the plow.
2. Turn on the plow controller, and slowly back up toward the plow.
3. Connect the ground/power and plow wire harnesses, and raise the coupler assembly.
4. Slowly back up until the coupler assembly attachment arms contact the undercarriage pin.
5. Slide the attachment pins through the holes in the attachment arms and undercarriage and secure them with a linchpin.
6. Attention—read the *Owner's Manual* before removing the plow.
7. Retract the plow wings.
8. Remove the linchpins and attachment pins from the attachment arms and undercarriage.
9. Disconnect the ground/power and plow wire harnesses, and slowly drive forward.
10. Turn off the plow controller.

Setup

Note: Determine the left and right sides of the machine from the normal operating position.

Installing the Plow Wings

1. Interlock the center blade and blade wing hinges, ensuring the cutting edges are even (Figure 4).

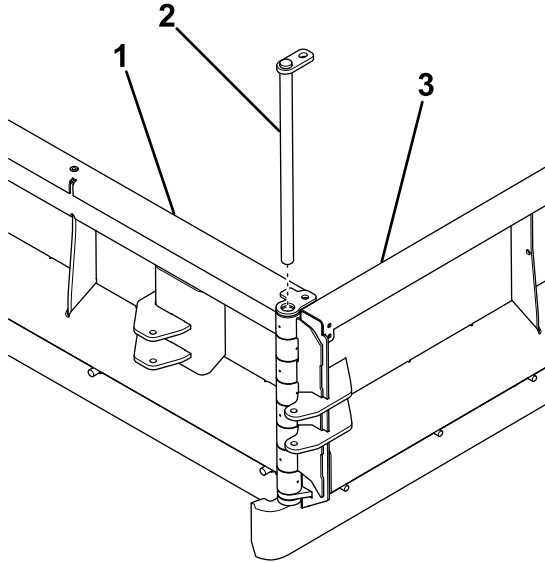

Figure 4

g295622

1. Center blade
2. Hinge pin
3. Blade wing

2. Lock the hinges together by inserting the hinge pin down the center (Figure 4).
3. Secure the hinge pin to the center blade with a bolt (1/2 x 3 inches) and jam nut (Figure 5).

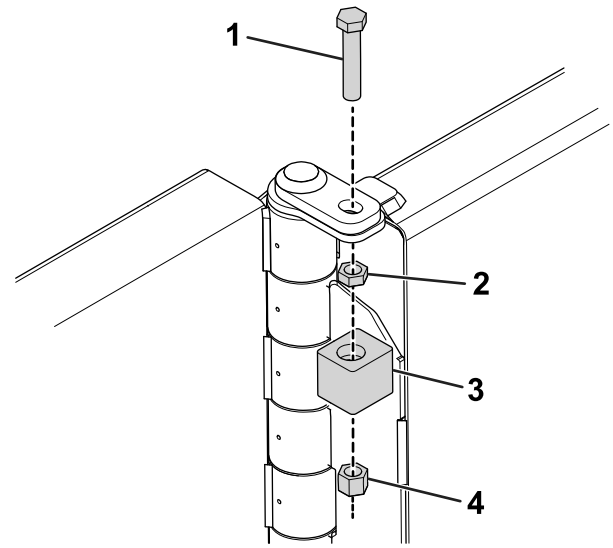

Figure 5

g294996

1. Bolt (1/2 x 3 inches)
2. Jam nut
3. Bumper
4. Locknut

4. Slide the bumper over the jam nut and secure it to the bolt using a locknut (Figure 5).

Installing the Lift Arm and Top Links

1. Loosely attach the flat end of the lift arm to the lower brackets on the center blade using 2 bolts (5/8 x 4 inches) and locknuts (Figure 6).

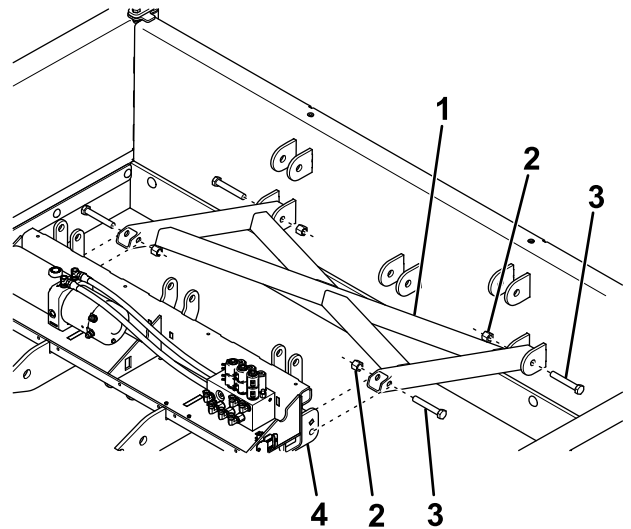

Figure 6

g252227

1. Lift arm
2. Locknut (5/8 inch)
3. Bolt (5/8 x 4 inches)
4. Coupler assembly bracket

2. Loosely attach the angled end of the lift arm to the lower brackets on the coupler assembly using 2 bolts (5/8 x 4 inches) and locknuts (Figure 6).

- Loosely attach the top links to the upper brackets on the center blade using 2 bolts (3/4 x 4 inches) and locknuts as shown in [Figure 7](#).

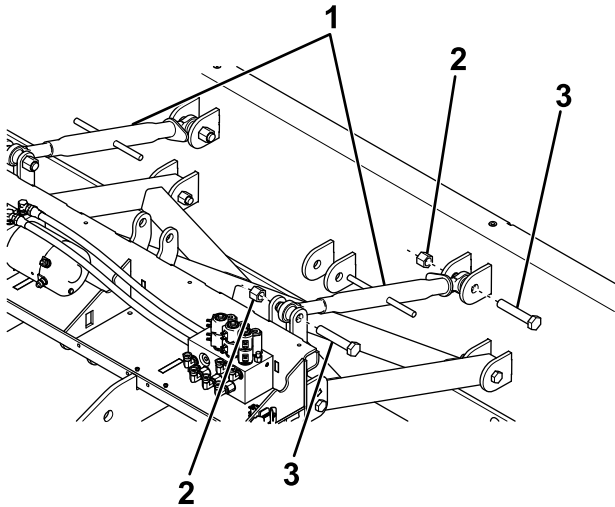

Figure 7

g252228

- Top links
- Locknut (3/4 inch)
- Bolt (3/4 x 4 inches)

- On the opposite side of the blade, loosely attach the body end of the 2 wing hydraulic cylinders to the center blade using 2 bolts (1/2 x 4 inches) and locknuts (1/2 inch) as shown in [Figure 9](#).

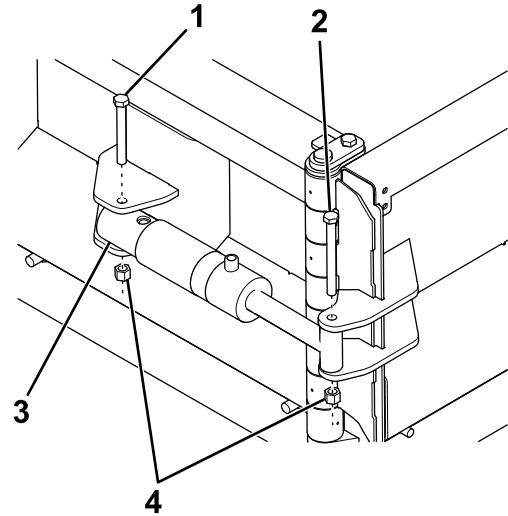

Figure 9

g252230

- Bolt (1/2 x 4 inches)
- Shear bolt (1/2 x 5 inches)
- Wing hydraulic cylinder
- Locknuts (1/2 inch)

- Loosely attach the top links to the upper brackets on the coupler assembly using 2 bolts (3/4 x 4 inches) and locknuts ([Figure 7](#)).

- Loosely attach the arm end of the wing hydraulic cylinders to the blade wings using 2 shear bolts (1/2 x 5 inches) and locknuts (1/2 inch) as shown in [Figure 9](#).

Installing the Hydraulic Cylinders

- Loosely attach the lift cylinder to the center bracket on the center blade using a bolt (3/4 x 4 inches) and locknut as shown in [Figure 8](#).

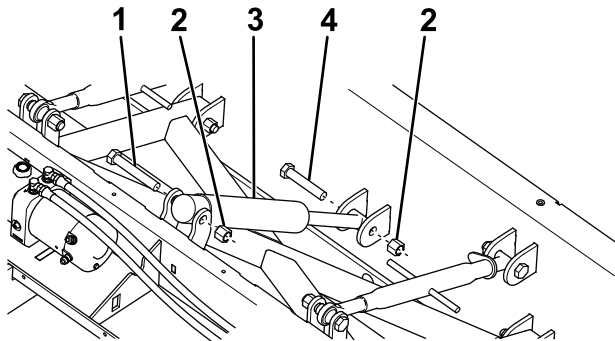

Figure 8

g252229

- Bolt (3/4 x 4-3/4 inches)
- Locknut (3/4 inches)
- Lift cylinder
- Bolt (3/4 x 4 inches)

- Loosely attach the other end of the lift cylinder to the center bracket on the coupler assembly using a bolt (3/4 x 4-3/4 inches) and locknut ([Figure 8](#)).

Torquing the Fasteners

Torque all of the fasteners to the following specifications

- 1/2-inch shear bolts to 40 N·m (30 ft-lb)
- the remaining 1/2-inch bolts to 76 N·m (56 ft-lb)
- 5/8-inch bolts to 153 N·m (113 ft-lb)
- 3/4-inch bolts to 272 N·m (201 ft-lb)

Installing the Hydraulic Hoses

1. Connect the hydraulic hoses to the hydraulic manifold as shown in [Figure 10](#).

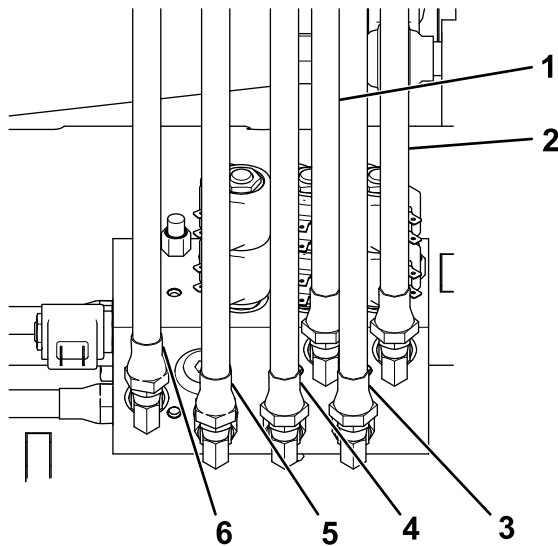
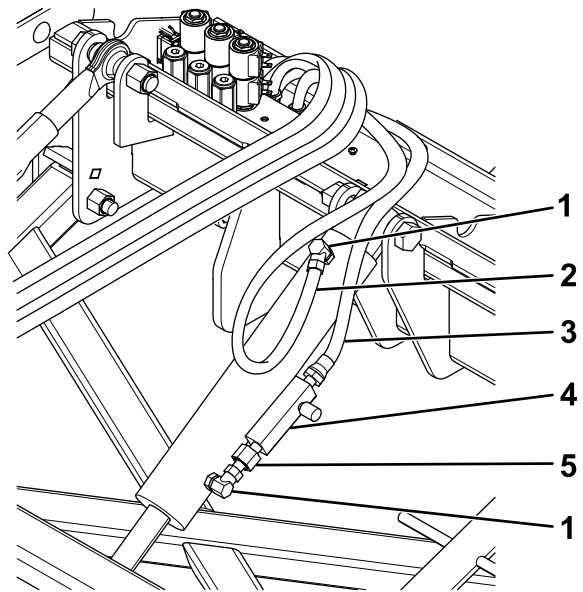

Figure 10

g252231

1. XR2—long hose
2. XL2—long hose
3. XL1—long hose
4. XR1—long hose
5. C1—short hose
6. C2—medium hose

2. Route the hoses toward the lift cylinder ([Figure 11](#)).



g252232

Figure 11

1. 90° fitting
2. Short hose from C1
3. Medium hose from C2
4. Flow control valve
5. Coupler

3. Attach the 90° fittings to the lift cylinder as shown in [Figure 11](#).
4. Attach the flow control valve to the 90° fitting on the bottom of the lift cylinder using the coupler ([Figure 11](#)).

Note: Ensure that the adjustment knob on the valve is positioned towards the coupler assembly as shown in [Figure 11](#).

5. Secure the short hose to the top fitting on the lift cylinder ([Figure 11](#)).
6. Secure the medium hose to the flow control valve ([Figure 11](#)).
7. Route the long hoses connected to XR1 and XR2 on the hydraulic manifold to the right side of the plow, and loosely secure them to the center blade using a hose clamp, clamp plate and bolt (5/16 x 2-1/2 inches) as shown in [Figure 12](#).

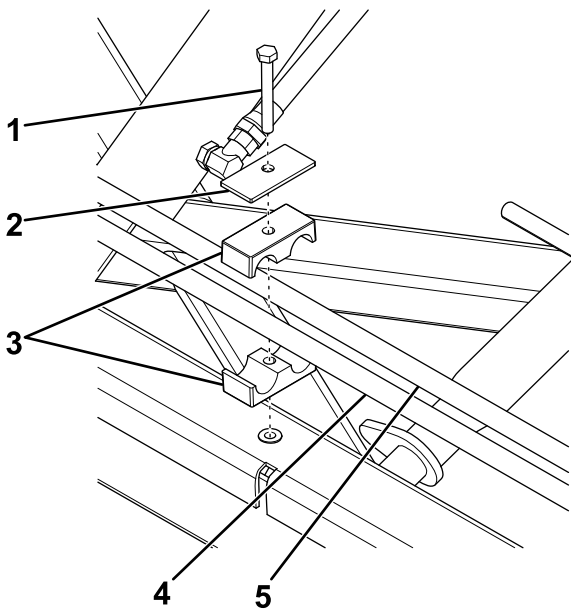

Figure 12

g252233

1. Bolt (5/16 x 2-1/2 inches)
2. Clamp plate
3. Hose clamp
4. Hose from XR2
5. Hose from XR1

8. Route the hose from XR2 to the outside fitting on the wing hydraulic cylinder (**Figure 13**).

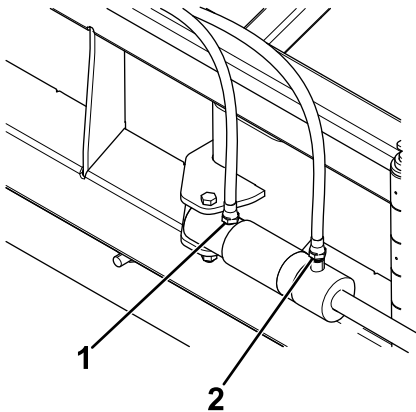

Figure 13

g252240

1. Hose from XR1
2. Hose from XR2

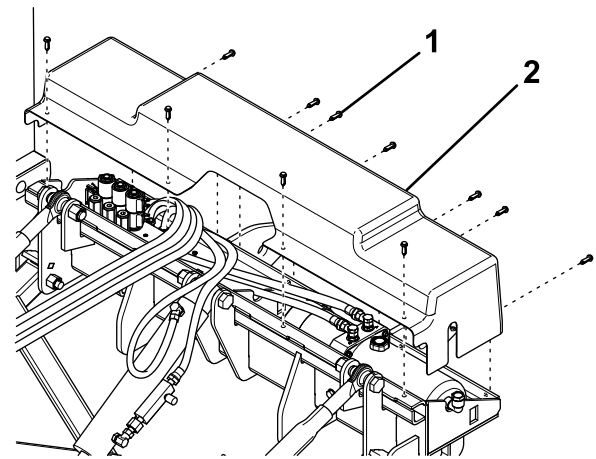

Figure 14

g252234

1. Push rivet
2. Coupler assembly cover

Installing the Blade Guides and Filling the Hydraulic Reservoir

1. Attach the blade guides to the wing blade using 4 bolts (5/16 x 1 inch) and locknuts (**Figure 15**).

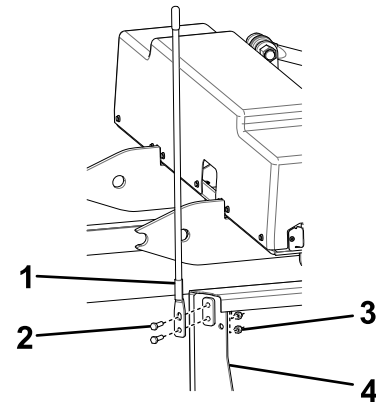

Figure 15

g252235

1. Blade guide
2. Bolts (5/16 x 1 inch)
3. Locknut (5/16 inch)
4. Wing blade

2. Torque the bolts to 19 N·m (14 ft-lb).
3. Remove the fill cap from the hydraulic reservoir on the side of the coupler assembly (**Figure 16**).

9. Route the hose from XR1 to the inside fitting on the wing hydraulic cylinder (**Figure 13**).
10. Adjust the amount of slack the hoses have near the blade then tighten the hose clamp to secure them. Torque the bolts to 19 N·m (14 ft-lb).
11. Repeat steps 7 through 10 with the long hoses connected to XL1 and XL2 and the left side of the plow.
12. Attach the coupler assembly cover using 11 push rivets (**Figure 14**).

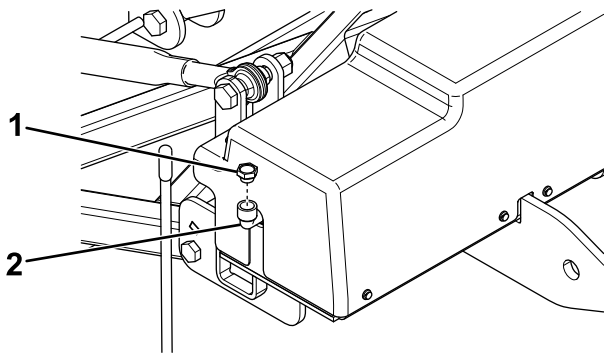

Figure 16

g252236

1. Fill cap
2. Fill elbow

4. Slowly fill the reservoir with BOSS high-performance hydraulic fluid until it accepts no more.

Note: The reservoir holds approximately 1.9 L (2 US qt) of hydraulic fluid.

5. Install the previously removed fill cap.

Important: Ensure that all wiring is secured in a position that avoids hot or moving parts to prevent damage to the vehicle or plow.

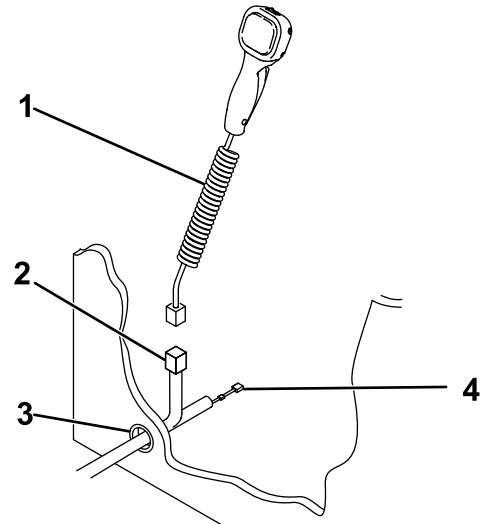

Figure 17

g252336

1. Plow controller
2. Controller connector
3. Rubber grommet
4. Black/red wire with in-line fuse

Installing the Wire Harness

⚠ DANGER

Vehicle engines contain moving parts and can become extremely hot, capable of causing severe burns and serious bodily harm.

Shut off the engine and allow it sufficient time to cool down before installing this kit.

⚠ DANGER

Vehicle batteries can cause dangerous electrical shocks that could lead to severe burns or death.

Disconnect your battery before installing this kit. Remove the negative cable first, then remove the positive cable.

Note: Apply dielectric grease to all electrical connections.

1. Ensure that the vehicle firewall is clear of obstructions.
2. Drill a 3 cm (1-1/4 inch) diameter hole through the firewall on the driver side of the vehicle.

Note: The hole should be in an easily accessible area.

3. Insert the split rubber grommet into the hole.
4. Pull the plow controller connector and black/red wire with an in-line fuse into the vehicle cab through the hole in the firewall (Figure 17).

5. Plug the controller connector into the plow controller.
6. Mount the plow controller; refer to [Mounting the Plow Controller \(page 12\)](#).
7. Connect the black/red wire with an in-line fuse to a keyed 12 V + ignition source.
Note: Connecting the wire to a source that is not keyed can cause the battery to drain.
8. Mount the pump solenoid inside the engine compartment of the vehicle, ensuring that it stays in an upright position and does not contact the body, hood, or other conductive material on the vehicle.
9. Connect the white/black wire from the wire harness to the small post on the pump solenoid (Figure 18).

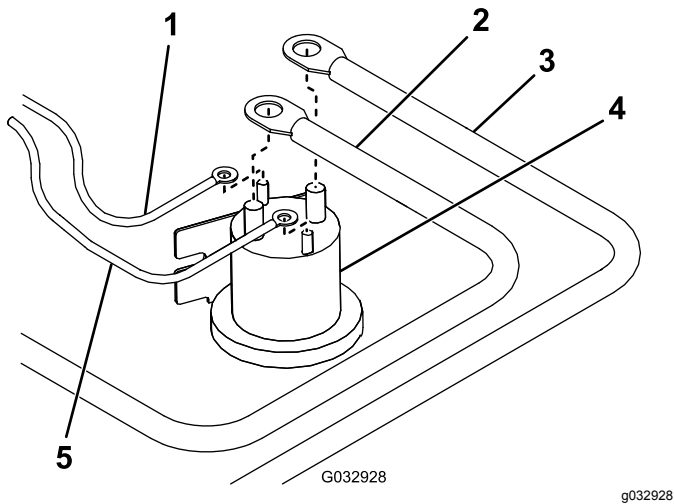

Figure 18

- | | |
|---------------------------|---|
| 1. White/black wire | 4. Solenoid |
| 2. Battery cable | 5. Brown wire with small ring connector |
| 3. Red power/ground cable | |

10. Connect the brown wire with the small ring connector to the other small post on the pump solenoid (Figure 18).

Note: The wires may go on either small post, but should not share a post.

11. Connect the red power/ground cable to the large post on the pump solenoid (Figure 18).
12. Connect the battery cable to the other large post on the pump solenoid (Figure 18).

Note: The wires may go on either large post, but should not share a post.

13. Connect the black power/ground cable to the negative (-) battery terminal (Figure 19).

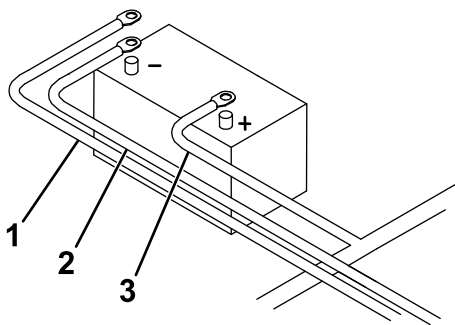

Figure 19

- | | |
|---|----------------------------|
| 1. Brown wire with large ring connector | 3. Battery cable connector |
| 2. Black power/ground cable | |

14. Connect the brown wire with the large ring connector from the wire harness to the negative (-) battery terminal (Figure 19).

15. Connect the free end of the battery cable to the positive (+) battery terminal (Figure 19).
16. Route the plow connector and power/ground connector along the vehicle frame to the rear bumper.
17. Mount the plow connector and the black and red power/ground connector to the lower part of the rear bumper using a cable tie (Figure 20).

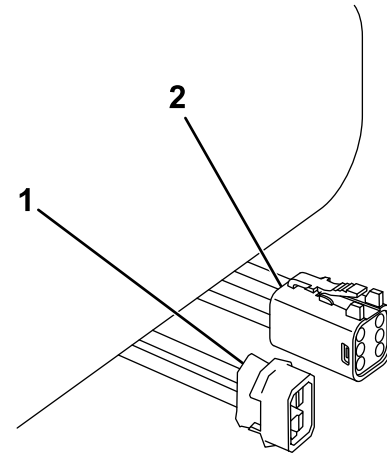

Figure 20

- | | |
|---------------------------|-------------------|
| 1. Power/ground connector | 2. Plow connector |
|---------------------------|-------------------|

18. Secure the wire harness to the vehicle frame using cable ties.

Important: Ensure that all wiring is secured in a position that avoids hot or moving parts to prevent damage to the vehicle or plow.

Mounting the Plow Controller

Note: Mount the controller in the cab in a dry area where it does not interfere with vehicle operation or visibility.

Important: Do not install the swivel mount when temperatures are below 16°C (60°F).

⚠ DANGER

The controller could cause serious injury if contacted during a crash.

Mount the controller in a location that vehicle occupants will not contact during a crash.

1. Determine the mounting location for the controller.
2. Clean the location with the provided alcohol wipe and dry it with a cloth or paper towel.

3. Clean the back of the swivel mount ([Figure 21](#)) with the alcohol wipe and then dry it.

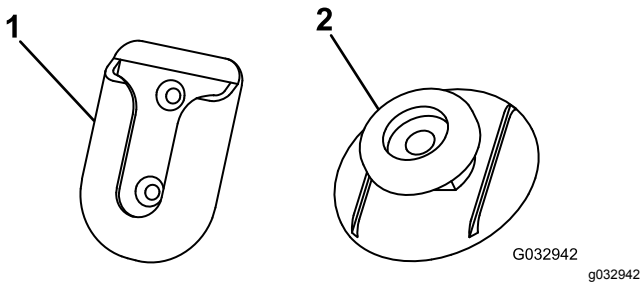

Figure 21

1. Swivel mount
2. Mounting tab

-
4. Remove the backing from 1 side of the adhesive and apply it to the back of the swivel mount.
 5. Remove the remaining backing from the swivel-mount adhesive and press the swivel mount to the clean area of the dashboard for 30 seconds.

Important: Once the mount is placed, you cannot remove it without destroying the adhesive.

6. Clean the back of the controller with the alcohol wipe and then dry it.
7. Remove the backing from 1 side of the adhesive and apply it to the back of the mounting tab ([Figure 21](#)).
8. Remove the remaining backing from the controller adhesive and press the mounting tab to the controller for 30 seconds.
9. Let the swivel mount rest unused for 72 hours before sliding the controller into the mounting bracket.

Important: Mounting the controller immediately may cause the adhesive to fail.

10. Continue the wire harness installation from step 7 of [Installing the Wire Harness \(page 11\)](#).

Adjusting the Pushbeam Height

Refer to [Adjusting the Pushbeam Height \(page 16\)](#) to ensure the pushbeam is at the correct height before mounting the plow.

Mounting the Plow

Refer to [Mounting the Plow \(page 17\)](#) to mount the plow.

Adjusting the Angle of Attack

Refer to [Adjusting the Angle of Attack \(page 17\)](#) to adjust the plow.

Product Overview

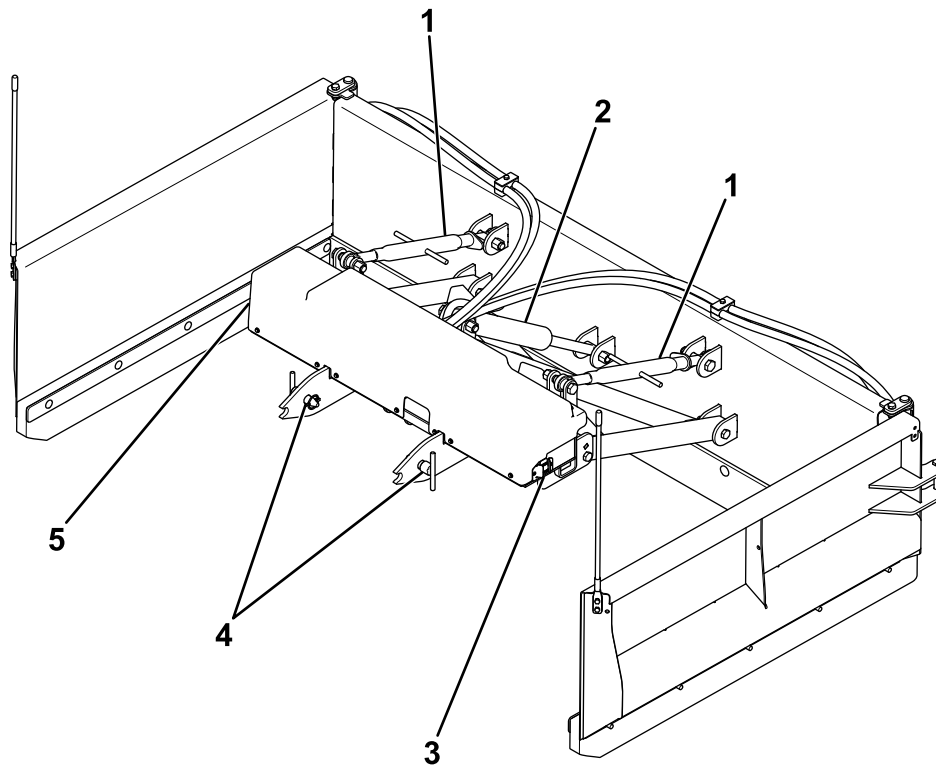

Figure 22

g252242

- | | |
|---------------------------------|-----------------------------------|
| 1. Top link | 4. Attachment pin |
| 2. Hydraulic flow-control valve | 5. Hydraulic reservoir fill elbow |
| 3. Coupler switch | |

Controls

Become familiar with all the controls before you operate the plow.

Coupler Switch

The coupler switch controls the movement of the coupler to facilitate plow attachment and removal. The switch is live as soon as the plow receives power. Press the switch up to raise the coupler and down to lower the coupler.

Controller

- Raise button—raises the plow blade
- Lower button—lowers the plow blade
- Left Wing Out button—moves the left wing out
- Right Wing Out button—moves the right wing out
- Left Wing In button—moves the left wing in
- Right Wing In button—moves the right wing in

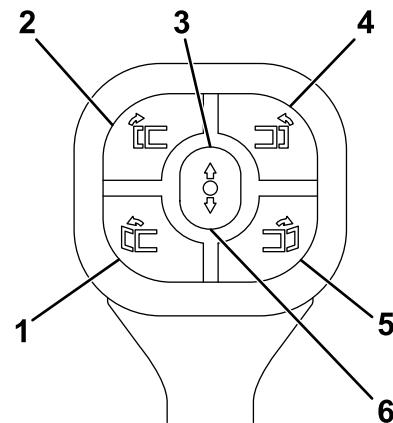

Figure 23

g234473

- | | |
|-------------------------|--------------------------|
| 1. Left Wing Out button | 4. Right Wing In button |
| 2. Left Wing In button | 5. Right Wing Out button |
| 3. Raise button | 6. Lower button |

Hydraulic Flow-Control Valve

The hydraulic flow-control valve adjusts the speed in which the plow raises and lowers. Refer to [Adjusting the Hydraulic Lowering Speed \(page 21\)](#).

Top Link

The top links adjust the plow angle of attack. Refer to [Adjusting the Angle of Attack \(page 17\)](#).

Specifications

Wing model	RPL21612	RPL21616
Wing blade width	61 cm (2 ft)	122 cm (4 ft)
Blade width (with wings retracted)	244 cm (8 ft)	244 cm (8 ft)
Blade width (with wings extended)	3.6 m (12 ft)	4.9 m (16 ft)
Blade height	61 cm (2 ft)	61 cm (2 ft)
Recommended push beam height	48.2 cm (19 inches)	48.2 cm (19 inches)
Weight	358 kg (790 lb)	404 kg (890 lb)

Attachments/Accessories

A selection of BOSS approved attachments and accessories is available for use with the machine to enhance and expand its capabilities. Contact your Authorized Service Dealer or authorized BOSS distributor or go to www.BOSSPlow.com for a list of all approved attachments and accessories.

To ensure optimum performance and continued safety certification of the machine, use only genuine BOSS replacement parts and accessories. Replacement parts and accessories made by other manufacturers could be dangerous, and such use could void the product warranty.

Operation

Before Operation

- Read and understand the *Owner's Manual* before operating or servicing your snowplow.
- Become familiar with local snowplowing laws and regulations.
- Carry the following safety equipment and items in case of emergencies:
 - fire extinguisher
 - tool kit
 - tow strap
 - flashlight
 - flares
 - first-aid kit
 - fuses for your vehicle
 - jumper cables
 - lock deicer
 - ice scraper
 - washer fluid
 - shovel
 - bag of salt or sand

Note: In case of emergencies, always carry a cell phone or 2-way radio when plowing.

- Wear warm clothes while plowing, including insulated boots, insulated underwear, a warm jacket, hat, gloves, and sunglasses.
- Carry the following snowplow equipment in case of emergencies:
 - hydraulic fluid
 - hydraulic hoses
 - pump solenoid
 - cutting-edge bolts
 - Grade 2 shear bolts
- Ensure that your vehicle has been maintained according to the manufacturer's recommendation.
- Consider adding a strobe light or backup lights to your vehicle if they are not already equipped.
- Ensure that your vehicle complies with the federal requirements for front and rear weight distribution. Any ballast should be placed behind the rear axle toward the tailgate and secured in place.
- Ensure that all snowplow bolts are tight and torqued properly.
- Ensure that your snowplow blade is not over-worn and in need of replacing.

- Do not exceed 64 km/h (40 mph) when transporting plow.
- When transporting the plow, keep the plow wings retracted to reduce the chance of catching a curb, snowbank, or other vehicles.
- Turn off the plow controller when transporting the plow to and from a job site.
- When transporting the plow, do not block your vision with the raised plow.
- Before it snows, inspect the location you will be plowing and look for obstacles that will become hidden once it snows. Look for things such as bumper stops, speed bumps, curbs, shrubs, water drains, fire hydrants, fences, and pipes. To prevent damaging the area being plowed, your plow, or your vehicle, mark any obstructions in a way that will be visible after it snows.

Adjusting the Pushbeam Height

1. Measure the distance from the ground to the attachment pin holes on the undercarriage pushbeam (Figure 24). The distance should be 48.2 cm (19 inches).

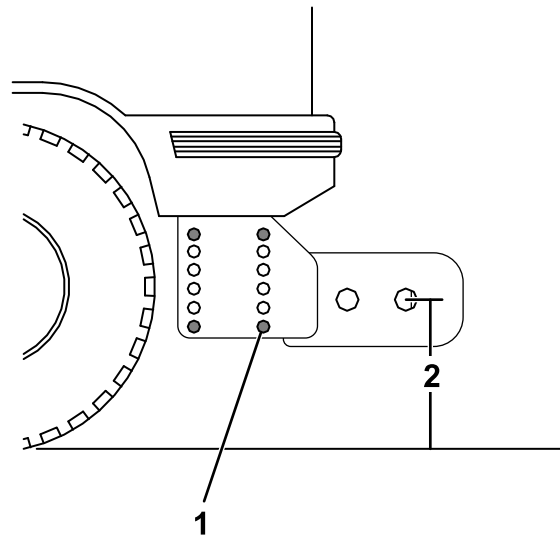

Figure 24

g252337

1. Fastener
 2. Measure this distance.
-
2. If the pushbeam is not at 48.2 cm (19 inches), remove the fasteners securing the pushbeam to the undercarriage (Figure 24).
 3. Move the pushbeam up or down and secure it with the previously removed hardware.
 4. Torque the fasteners to 76 N·m (56 ft-lb).

Mounting the Plow

The vehicle must be running before starting this procedure.

1. Turn on the plow controller.
2. Line up the vehicle with the snowplow and slowly drive backward until you are close enough to connect the plow wire harness and power/ground cable to the vehicle wire harness.
3. Remove the electrical-plug dust-covers and connect the plow wire harness and power/ground cable to the vehicle wire harness.
4. Use the coupler switch to raise or lower the plow to the desired height, then slowly drive backward until the attachment arms contact the undercarriage pin (Figure 25).

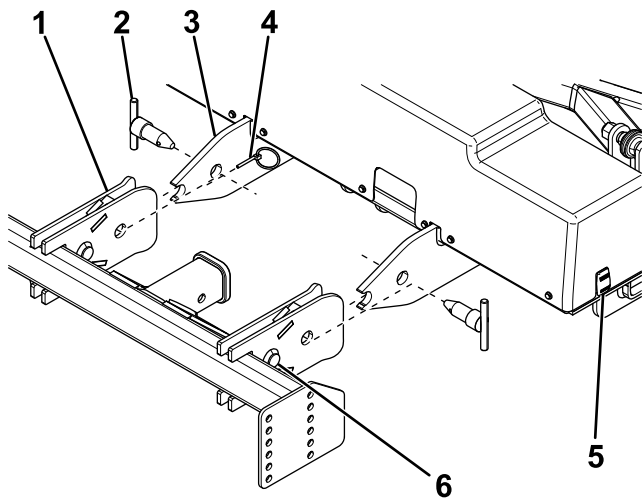

Figure 25

g234472

- | | |
|-------------------|----------------------|
| 1. Undercarriage | 4. Linchpin |
| 2. Attachment pin | 5. Coupler switch |
| 3. Attachment arm | 6. Undercarriage pin |

5. Slide the attachment pins through the holes in the attachment arms and undercarriage and secure them with a linchpin (Figure 25).

Adjusting the Angle of Attack

1. Park the vehicle on a level surface and lower the plow until it just barely touches the ground.

Note: Apply as little down pressure as possible.

2. Loosen the top link locks (Figure 26).

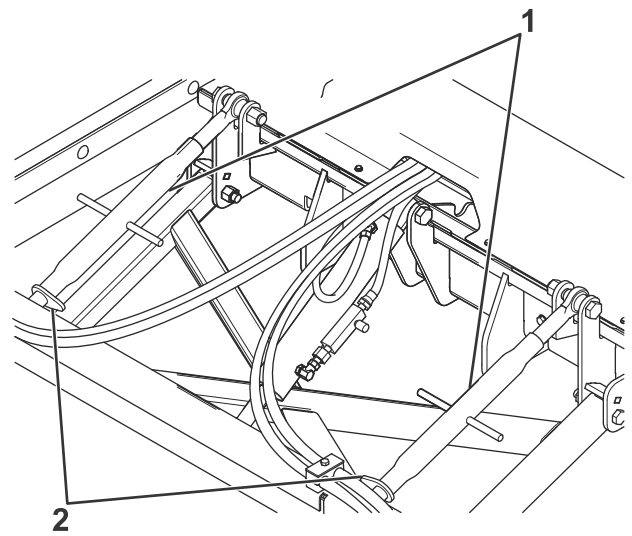

Figure 26

g295697

- | | |
|-------------------|--------------|
| 1. Top link locks | 2. Top links |
|-------------------|--------------|

3. Adjust the top links so that the wing tips are 5 to 7 cm (2 to 3 inches) off the ground.

Rotate the top links clockwise to lower the wing tips. Rotate the top links counterclockwise to raise the wing tips.

4. Tighten the top link locks.

Checking the Hydraulic Fluid

1. With the plow mounted to the vehicle, lower the plow to the ground.
2. Clean the area around the fill cap (Figure 27).

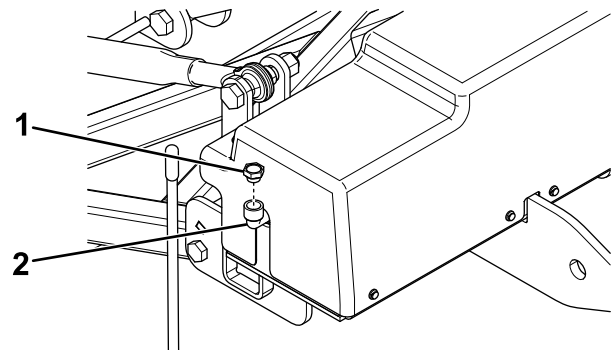

Figure 27

g252236

- | | |
|-------------|---------------|
| 1. Fill cap | 2. Fill elbow |
|-------------|---------------|

3. Remove the fill cap from the hydraulic reservoir (Figure 27).

4. Ensure that the fluid comes up to the bottom of the fill elbow. If it does not, add more hydraulic fluid; refer to Adding Hydraulic Fluid (page 18).

5. Install the previously removed fill cap.

Adding Hydraulic Fluid

1. Ensure that the coupler is at the recommended pushbeam height and the lift cylinder is completely collapsed.
2. Clean the area around the fill cap (Figure 28).

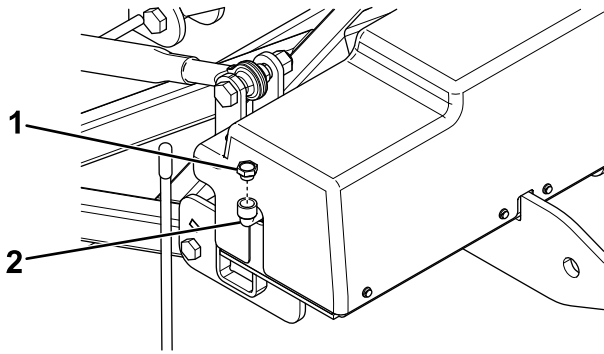

Figure 28

g252236

1. Fill cap

2. Fill elbow

3. Remove the fill cap from the hydraulic reservoir (Figure 28).
4. Slowly fill the reservoir with BOSS high-performance hydraulic fluid to the bottom of the fill elbow (Figure 28).

Note: The reservoir holds approximately 1.9 L (2 US qt) of hydraulic fluid.

5. Install the previously removed fill cap.
6. Start the vehicle and operate the plow in its full range of movement.
7. Stop the vehicle, check the hydraulic-fluid level, and replenish the fluid if necessary; refer to [Checking the Hydraulic Fluid \(page 17\)](#).

During Operation

- Do not exceed 22 km/h (14 mph) when plowing.
- Always wear a seatbelt while plowing.
- Never plow with your head out the window.
- When moving in reverse, turn and look behind you instead of relying on vehicle mirrors.
- Start driving forward before lowering the plow for a pass.
- As you come to the end of a pass, lift off the accelerator while starting to use the brake. At the same time, start to raise the blade to help stack the snow and to reduce the load on the electrical system of your vehicle.

Plowing

1. Back up the vehicle to the where you will start plowing.

2. Extend the plow wings if desired.
3. Lower the plow blade and begin to slowly drive forward.
4. Once the area has been cleared, raise the plow and retract the wings, if extended.

Protecting Your Transmission

Transmission damage is a common problem that occurs while plowing. The following steps can help prevent transmission damage:

- Do not plow in overdrive unless the *Owner's Manual* for your vehicle recommends it.
- Plan your plow pattern so that you drive forward as much as possible.
- Come to a complete stop before shifting from forward to reverse.
- Wait until the transmission engages before accelerating.
- Accelerate slowly, allowing the tires to grip the road surface for better traction. Avoid spinning the tires.
- Start driving forward before lowering the plow for a pass.
- Whenever possible, back into a cleared area.
- If you have a manual transmission, avoid riding the clutch while plowing.
- Change the transmission fluid before and during the plowing season. If the fluid has a burnt smell, change the fluid as soon as possible.
- You can install an inline transmission heat gauge to monitor the temperature in your transmission. If it reaches 121°C (250°F), let the vehicle idle until the fluid cools.

Plowing Parking Lots

- Make sure you know where the customer wants you to pile the snow.
- Use caution when plowing next to curbs.
- If a significant amount of snow is expected, plow during the storm rather than letting snow accumulate.
- Keep water drains and catch basins clear at all times.
- Do not stack snow by the road and block the visibility of vehicles coming or leaving the parking lot.
- Use caution when plowing next to parked cars.
- When plowing snow that is next to a building, move snow away from the building.

- If you are responsible for clearing sidewalks, shovel them first so that you can plow the snow away.
- Plow areas in front of buildings and overhead doors first.
- Move the snowbanks back far enough to accommodate future snowfalls.
- After moving snow away from a building, start plowing the lot. Begin by making a pass down the center of the lot, and then move snow in windrows to the outer edges. If there has been a significant amount of snowfall, move as much bulk off the lot as possible, then go over it again. In large lots, it may be best to break your plowing down into smaller areas.
- Do not pile snow in the middle of the lot. It will be difficult to remove later.
- Do not pile snow near handicapped parking areas.
- Plow in straight lines whenever possible, and move snow to the outer edges of the lot. Keep the wind direction in mind and pile snow downwind to minimize drifting.
- Plow snow during low-traffic hours, and always be cautious of cars and people in the lot.
- Once the majority of snow is removed from the lot, start the cleanup work. Begin by plowing next to curbs. Be sure to square off corners where possible, and don't leave trails of snow behind.

Operating Tips

When plowing wet snow, plow until the job is complete. Wet snow left in windrows overnight can freeze and turn into tank traps.

After Operation

- Lower the blade to the ground and turn off the plow controller when you have finished plowing.
- After plowing, let the vehicle idle for at least 10 minutes to allow the transmission fluid time to cool.

Removing the Plow

The vehicle must be running before starting this procedure.

1. Turn on the plow controller.
2. Ensure that the plow wings are retracted and lower the plow blade completely.

▲ WARNING

The plow is heavy and could fall and crush the operator or damage the plow if the wings are not retracted before removal.

Retract the plow wings before removing the plow.

3. Disconnect the plow wire harness and power/ground connector from the vehicle wire harness.
4. Install dust caps on the connectors.
5. Remove the attachment pins securing the plow to the undercarriage (Figure 29).

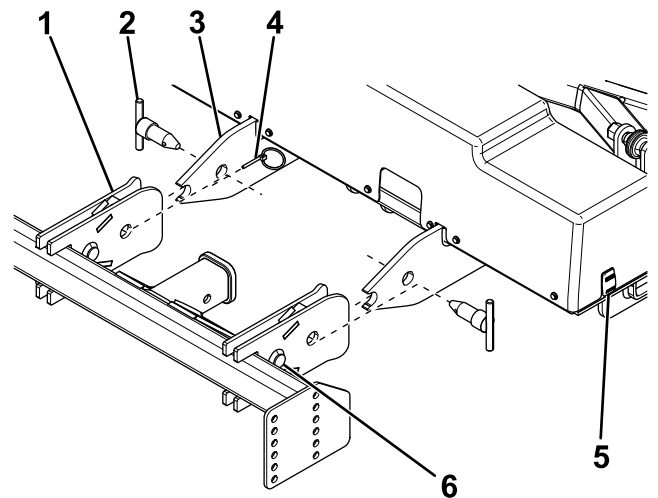

Figure 29

g234472

- | | |
|-------------------|----------------------|
| 1. Undercarriage | 4. Linchpin |
| 2. Attachment pin | 5. Coupler switch |
| 3. Attachment arm | 6. Undercarriage pin |
-
6. Slowly drive forward.
 7. Turn the controller off.

Maintenance

⚠ WARNING

Failure to properly maintain the machine could result in premature failure of machine systems causing possible harm to you or bystanders.

Keep the machine well maintained and in good working order as indicated in these instructions.

⚠ CAUTION

If you leave the key in the switch, someone could accidentally start the engine and seriously injure you or other bystanders.

Remove the key from the switch before you perform any maintenance.

Note: Determine the left and right sides of the machine from the normal operating position.

Recommended Maintenance Schedule(s)

Maintenance Service Interval	Maintenance Procedure
Before each use or daily	<ul style="list-style-type: none">• Check the hydraulic cylinders.• Check the hydraulic-fluid level.• Check the hydraulic lines and hoses.• Check the torque of all fasteners, pins, retainers, nuts, and bolts.• Check the cutting edge.• Check the wire-harness connector.
Before storage	<ul style="list-style-type: none">• Grease the lift-cylinder rods.• Apply dielectric grease to the wire-harness connectors.
Monthly	<ul style="list-style-type: none">• Apply dielectric grease to the wire-harness connectors.
Yearly	<ul style="list-style-type: none">• Replace the hydraulic fluid.

Draining the Hydraulic Fluid

If the oil becomes contaminated, follow the instructions below or contact your authorized BOSS dealer to have the system flushed.

1. Park the vehicle on a level surface, lower the plow, turn off the vehicle, and remove the keys.
2. Clean the area around the hydraulic drain plug (Figure 30).

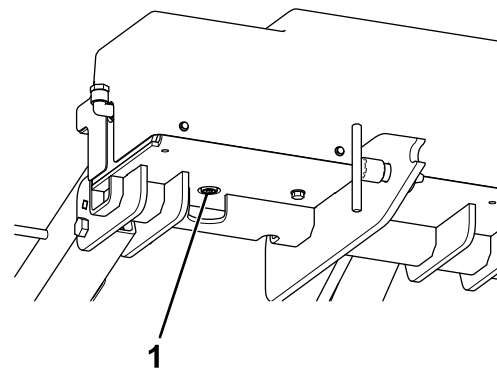

Figure 30

g252237

1. Drain plug
3. Place a drain pan under the plug and remove the plug.
4. Clean the drain plug.
5. Allow the fluid to fully drain, then replace the plug. Torque the plug to 17 to 28 N·m (150 to 250 in-lb).

Adding Hydraulic Fluid

1. Ensure that the coupler is at the recommended pushbeam height and the lift cylinder is completely collapsed.
2. Clean the area around the fill cap (Figure 31).

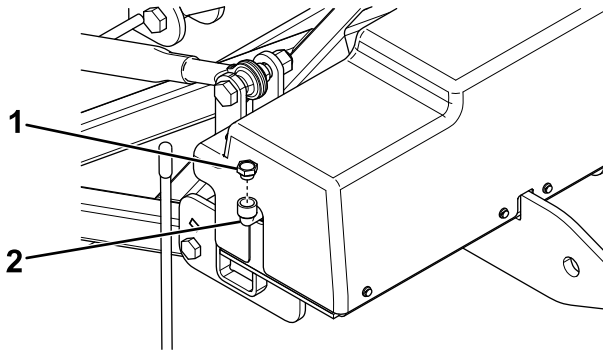

Figure 31

g252236

1. Fill cap
2. Fill elbow

3. Remove the fill cap from the hydraulic reservoir (Figure 31).
4. Slowly fill the reservoir with BOSS high-performance hydraulic fluid to the bottom of the fill elbow (Figure 31).

Note: The reservoir holds approximately 1.9 L (2 US qt) of hydraulic fluid.

5. Install the previously removed fill cap.
6. Start the vehicle and operate the plow in its full range of movement.
7. Stop the vehicle, check the hydraulic-fluid level, and replenish the fluid if necessary; refer to [Checking the Hydraulic Fluid \(page 17\)](#).

Adjusting the Hydraulic Lowering Speed

⚠ WARNING

Adjusting the flow-control valve can cause the plow to drop suddenly, resulting in bodily harm.

- Ensure that all observers are standing a safe distance away from the plow.
- Ensure that the controller is off before adjusting the plow.
- Keep your body away from the plow blade.

Adjust the valve on the hydraulic hose to the lower lift cylinder port (Figure 32).

Note: Turning the valve clockwise decreases the lowering speed; turning the valve counterclockwise increases the lowering speed.

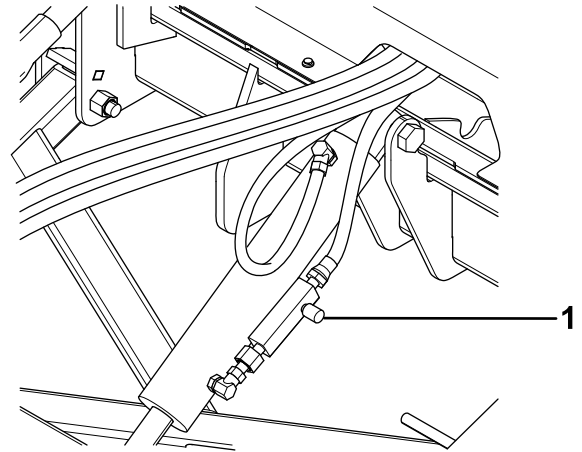

Figure 32

g252238

1. Flow control valve

Checking the Hydraulic Lines and Hoses

⚠ WARNING

Hydraulic fluid escaping under pressure can penetrate the skin and cause injury.

- Ensure that all hydraulic-fluid hoses and lines are in good condition and all hydraulic connections and fittings are tight before applying pressure to the hydraulic system.
- Keep your body and hands away from pinhole leaks or nozzles that eject high-pressure hydraulic fluid.
- Use cardboard or paper to find hydraulic leaks.
- Safely relieve all pressure in the hydraulic system before performing any work on the hydraulic system.
- Get immediate medical help if fluid is injected into skin.

Check the hydraulic lines and hoses daily for leaks, kinked lines, loose mounting supports, wear, loose fittings, weather deterioration, and chemical deterioration. Make all necessary repairs before operating.

Storage

Storing the Plow

1. Drive the snowplow to your storage location and remove the plow; refer to [Removing the Plow \(page 19\)](#).
2. Grease any exposed chrome or nitro bar on the hydraulic cylinders.
3. Apply dielectric grease to all of the wire-harness connectors and install the dust caps.
4. Lightly sand and use touch-up paint on painted areas that are scratched, chipped, or rusted.

Removing the Plow from Storage

1. Check the plow for cracked welds.
2. Check the torque of all fasteners, pins, retainers, nuts, and bolts; tighten as necessary.
3. Check the hydraulic lines and hoses for cracks or leaks.
4. Replace the hydraulic fluid; refer to [Draining the Hydraulic Fluid \(page 20\)](#).
5. Check the cutting edge for wear.
6. Lightly sand and use touch-up paint on painted areas that are scratched, chipped, or rusted.
7. Apply dielectric grease to all of the wire harness connectors.
8. Attach the plow to the vehicle; refer to [Mounting the Plow \(page 17\)](#).
9. Move the plow through its range of motion to check the hydraulic cylinder rods.

Troubleshooting

Problem	Possible Cause	Corrective Action
The pump motor does not run.	<ol style="list-style-type: none"> 1. The power/ground cables or control cables are not connected. 2. The pump motor has failed or the pump has seized 3. The cable between the battery and the solenoid is disconnected or broken. 4. The solenoid has failed. 5. Power from the relay is disconnected. 	<ol style="list-style-type: none"> 1. Connect the cables. 2. Check for voltage at the pump motor while the ignition switch is on and the Raise button is pressed on the controller. If voltage is present, replace the motor brushes or pump/motor assembly. 3. Check for power to the solenoid by testing for voltage between both large terminals and ground. If voltage is not present between one large terminal and ground, connect or replace the cable. 4. Check for voltage between the other large terminal of the solenoid and ground while jumping power to the small terminal with the white/black wire. If no voltage is present, replace the solenoid. If voltage is present, connect or replace the wire from the small terminal of the solenoid to ground. 5. Test the voltage between the black wire and ground at the white 9-pin connector. If no voltage is present, connect the relay. If voltage is present, check the wiring and controller switches.
The pump continues to run while the switch is in neutral.	<ol style="list-style-type: none"> 1. The solenoid has failed in the closed position. 2. There is a short between the black and white/black wire in the controller. 3. The switch has failed. 	<ol style="list-style-type: none"> 1. Disconnect the controller and turn the ignition on. If the pump continues to run, quickly remove power to the pump by disconnecting the power/ground cables to the plow and replace the solenoid. 2. Disconnect the controller and turn the ignition on. If the pump stops running, replace the wire. 3. Replace the switch.
The plow does not lower.	<ol style="list-style-type: none"> 1. The power/ground cables or control cables are not connected. 2. The flow-control valve is closed. 3. The wiring on the valve block is not connected. 4. The solenoid valve or valve coil has failed. 5. Power from the relays is disconnected. 	<ol style="list-style-type: none"> 1. Connect the cables if they are not connected. 2. Place the controller in neutral, then open the flow-control valve. 3. Refer to the wiring schematic. 4. Check for voltage between the solenoid valve terminal and ground while the ignition switch is on and the controller is in the Float position. If voltage is present, replace the valve or valve coil. 5. Check the voltage between the black wire and ground at the white 9-pin connector. If no voltage is present, connect the relays. If voltage is present, check the wiring and switch off the controller.
The plow lowers too fast.	<ol style="list-style-type: none"> 1. The flow-control valve is open too much. 	<ol style="list-style-type: none"> 1. Close the flow-control valve to the desired drop speed.

Problem	Possible Cause	Corrective Action
The plow does not raise or raises slowly.	<ol style="list-style-type: none"> 1. The hydraulic-fluid level is low. 2. The power/ground cables or the control cable are not connected. 3. The wiring on the valve block is not connected. 4. The battery is weak or needs replacing. 5. The motor brushes are bad. 6. The pump pressure relief valve is set to less than 172 bar (2,500 psi), contaminated, or damaged. 7. The pump is worn 8. The Raise control solenoid valve is not opening completely. 9. The Lower control solenoid valve is stuck open. 	<ol style="list-style-type: none"> 1. Check the hydraulic-fluid level; refer to the Checking the Hydraulic Fluid section. 2. Connect the cables. 3. Refer to the wiring schematic. 4. Load a test battery and replace it if necessary. 5. Check the motor brushes and replace them if necessary. 6. Ensure that the pressure is set to 172 bar (2,500 psi). Check the pressure again. If it is less than 172 bar (2,500 psi) at the end of the lift, clean or replace the pressure relief valve. 7. Replace the pump. 8. Replace the valve. 9. Replace the valve.
Oil leaks from the lift cylinders.	<ol style="list-style-type: none"> 1. The fittings are loose or the O-rings are damaged. 2. The rods are pitted or rough. 	<ol style="list-style-type: none"> 1. Tighten loose fittings. See your authorized BOSS dealer for a seal kit. 2. Polish them with a copus cloth or extra fine steel wool.
The vehicle battery dies when the vehicle is turned off.	<ol style="list-style-type: none"> 1. The wire harness isn't connected to a keyed fuse source. 	<ol style="list-style-type: none"> 1. Connect the wire harness to a keyed fuse source; refer to the wire schematic.
The vehicle battery dies when all of the switches are in the Neutral position.	<ol style="list-style-type: none"> 1. There is a short in the controller wiring. 2. There is a short in the wire harness. 3. There is a short in the valve coils. 	<ol style="list-style-type: none"> 1. Repair or replace the controller. 2. Repair or replace the wire harness. 3. Replace the valve coils.
Fluid is running out of the fill cap of the hydraulic pump.	<ol style="list-style-type: none"> 1. The terrain is too steep. 2. The pump reservoir is overfilled. 3. The plow is hitting snowbanks too hard. 	<ol style="list-style-type: none"> 1. Avoid steeply sloped areas. 2. The hydraulic fluid level should be within 2 cm (3/4 inch) of the top of the reservoir. 3. Do not plow recklessly.
The pump chatters when raising or angling the plow.	<ol style="list-style-type: none"> 1. The hydraulic-fluid level is low. 	<ol style="list-style-type: none"> 1. Check the hydraulic-fluid level; refer to the Checking the Hydraulic Fluid section.
While trying to raise the plow, the wing(s) extend prior to raising the plow and do(es) not retract.	<ol style="list-style-type: none"> 1. The pressure or return lines are incorrectly routed. 	<ol style="list-style-type: none"> 1. Ensure that the pressure line is connected from the "P" on the pump to the "P" on the valve manifold, and the return line is connected from the "T" on the pump to the "T" on the valve manifold.
The wings drift back when extended.	<ol style="list-style-type: none"> 1. The wing-return-solenoid valve on the manifold is contaminated. 2. The pressure-relief valve is contaminated. 	<ol style="list-style-type: none"> 1. Clean or replace it. 2. Clean or replace it.

Problem	Possible Cause	Corrective Action
The wing(s) do(es) not extend or extend slowly when the motor runs.	<ol style="list-style-type: none"> 1. The hydraulic-fluid level is low. 2. The power/ground cables or the control cable are not connected. 3. The wiring on the valve block is not connected. 4. The battery if it is weak or needs replacing. 5. The motor brushes are bad. 6. The pump pressure relief valve is set to less than 172 bar (2,500 psi), contaminated, or damaged. 7. The pump is worn 8. The Wing Out control solenoid valve is not opening completely. 9. The wiring or control box is not connected. 	<ol style="list-style-type: none"> 1. Check the hydraulic-fluid level; refer to the Checking the Hydraulic Fluid section. 2. Connect the cables. 3. Refer to the wiring schematic. 4. Load a test battery and replace it if necessary. 5. Check the motor brushes and replace them if necessary. 6. Ensure that the pressure is set to 172 bar (2,500 psi). Check the pressure again. If it is less than 172 bar (2,500 psi) at the end of the lift, clean or replace the pressure relief valve. 7. Replace the pump. 8. Replace it. 9. Refer to the wiring schematic.
The wing(s) extend, but do(es) not retract or retract slowly.	<ol style="list-style-type: none"> 1. The power/ground cables or control cable are not connected. 2. The wiring on the valve block is not connected. 3. The solenoid valve or valve coil has failed. 	<ol style="list-style-type: none"> 1. Connect the cables. 2. Refer to the wiring schematic. 3. Check for voltage between the solenoid valve terminal and ground while the ignition switch is on and the controller is in the Wing In position. If voltage is present, replace the valve or valve coil.
The plow wings do not extend or retract.	<ol style="list-style-type: none"> 1. If the status light on the plow module is green but not blinking, the controller is not communicating correctly. 2. If the status light on the plow module is orange, the plow module may be wired incorrectly. 3. If the status light on the plow module is blinking orange or red, there is a problem with the module driver. 4. If the status light on the plow module is off, the plow module is not getting power. 	<ol style="list-style-type: none"> 1. Check the controller connections. Replace the controller if it is broken. 2. Refer to the wiring diagram included with your <i>Owner's Manual</i>. 3. Check the module connections for shorts. Replace the module if it is broken. 4. Check that the controller is on and that all of the plugs are connected.
The wing(s) retract too easily while plowing.	<ol style="list-style-type: none"> 1. The pressure-relief valve pressure is set too low. 	<ol style="list-style-type: none"> 1. See an authorized BOSS dealer for pressure-relief-valve adjustment.

Schematics

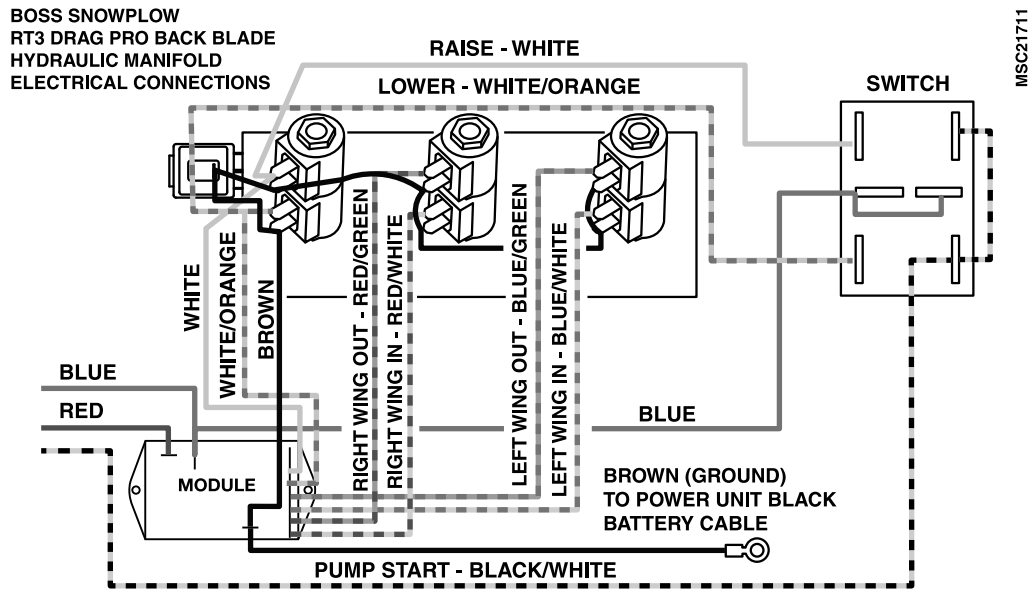

msc21711_b

Wire Color	Function
Blue/Green	Left Wing Out
Blue/White	Left Wing In
Red/White	Right Wing Out
Red/Green	Right Wing In
White	Raise
White/Orange	Lower
Red	Communication
Blue	Module Power
Black/White	Pump Start
Brown	Ground

Hydraulic Manifold Wiring (Rev. C)

Notes:

BOSS
S N O W P L O W