

BOSS Products limited consumer warranty and BOSS Products commercial warranty policies are located at [www.BOSSPlow.com](http://www.BOSSPlow.com).

Patents pending.

## Safety

- Always follow the vehicle manufacturer's recommendations relating to system installation. For recommended vehicle models, refer to the *BOSS Snowplow Application Chart and Selection Guide*.
- Never disable, remove, or relocate any sensors or other components related to the operation of the air bags.
- To comply with federal regulations and to assure a safe vehicle, do not exceed the front gross-axle-weight rating (FGAWR), rear gross-axle-weight rating (RGAWR), and the gross-vehicle-weight rating (GVWR) at any time.
- Due to the variety of equipment that you can install on the vehicle and undercarriage, do not exceed the front gross-axle-weight rating (FGAWR), rear gross-axle-weight rating (RGAWR), and the gross-vehicle-weight rating (GVWR) at any time. This may require weighing the vehicle and adding ballast as necessary. It may also limit the payload capacity of the vehicle.
- Do not exceed the vehicle manufacturer's recommended towing capacity.

## Installation

Determine the left and right sides of the machine from the normal operating position.

1. Park the machine on a level surface, shut off the engine, wait for all moving parts to stop, engage the parking brake, and remove the key.
2. Remove and retain the fasteners from the vehicle frame shown in [Figure 1](#).

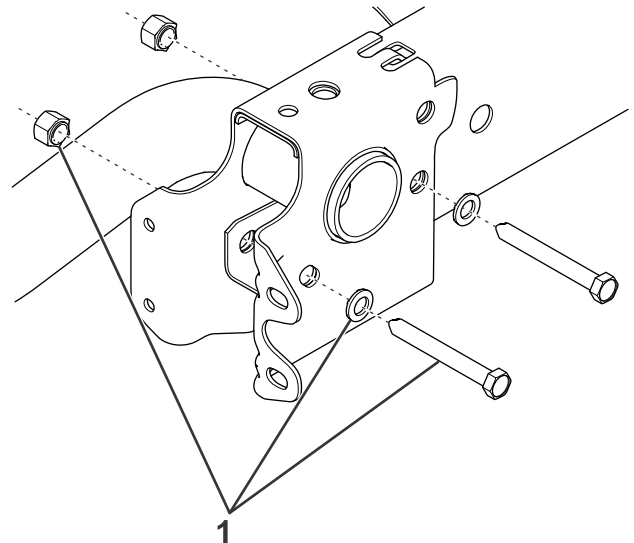

Figure 1

g295479

1. Remove and retain.

3. Using the sideplate as a guide, mark the position of the inner holes and drill them in the frame ([Figure 2](#)).



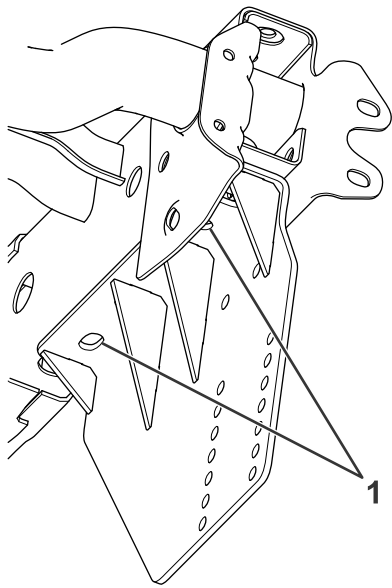
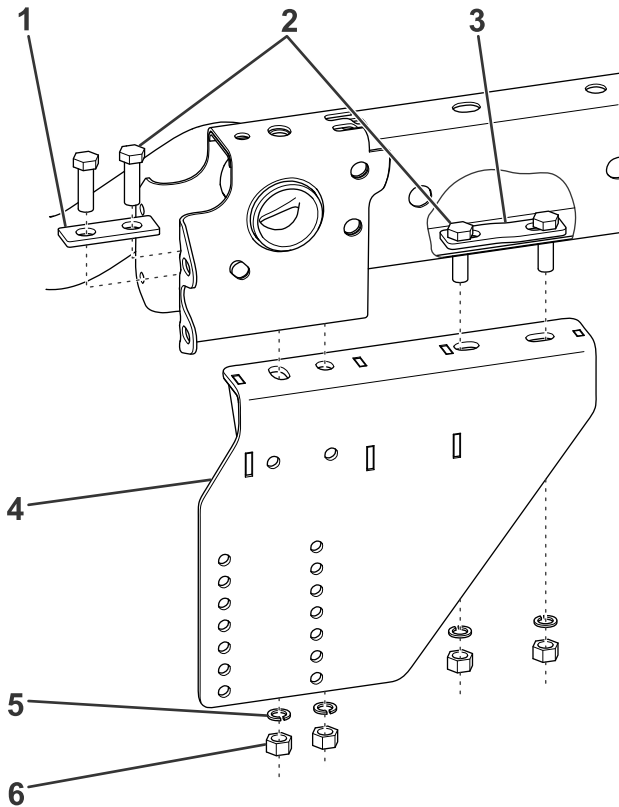

**Figure 2**

g295480

1. Drill

4. Loosely attach the sideplates to the frame using 4 bolts (5/8 inch), a straight spacer, an angled spacer, 4 split lockwashers, and 4 nuts (5/8 inch) as shown in [Figure 3](#).

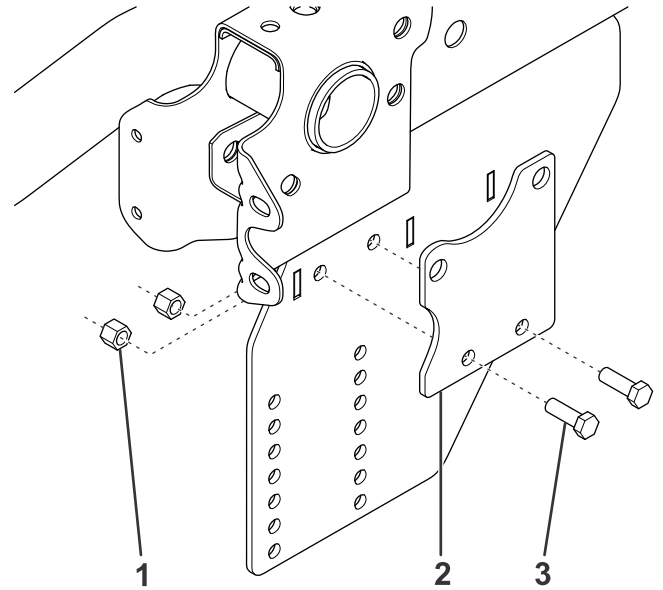

**Figure 3**

g295481

- |                    |                                |
|--------------------|--------------------------------|
| 1. Straight spacer | 4. Sideplate                   |
| 2. Bolt (5/8 inch) | 5. Split lockwasher (5/8 inch) |
| 3. Angled spacer   | 6. Nut (5/8 inch)              |

5. Loosely attach the bottom of the sidestraps to the sideplates using 2 bolts (1/2 inch) and nuts ([Figure 4](#)).

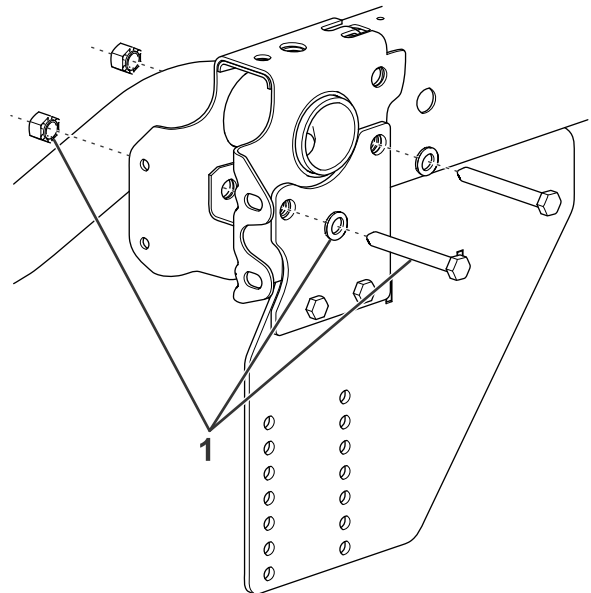

**Figure 4**

g295482

- |                   |                    |
|-------------------|--------------------|
| 1. Nut (1/2 inch) | 3. Bolt (1/2 inch) |
| 2. Sidetrail      |                    |

6. Secure the top of the sidestraps with the previously removed fasteners ([Figure 5](#)).



**Figure 5**

g295483

1. Previously removed fasteners

7. Loosely attach the pushbeam to the sideplates using 8 bolts (1/2 inch) and locknuts ([Figure 6](#)).

**Note:** Refer to your plow *Owner's Manual* for the appropriate pushbeam height.

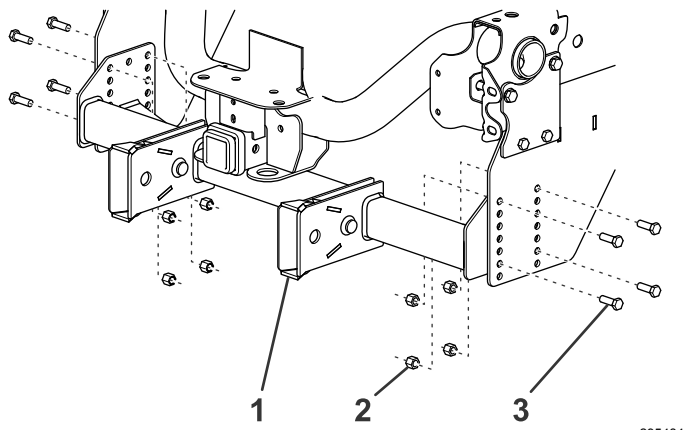

**Figure 6**

g295484

1. Pushbeam
2. Locknut (1/2 inch)
3. Bolt (1/2 inch)

- 
8. Torque all the fasteners to the following specifications:
    - 5/8-inch bolts to 153 N·m (113 ft-lb)
    - 1/2-inch bolts to 76 N·m (56 ft-lb)

**Note:** Torque the vehicle fasteners according to your vehicle manufacturer's recommendation.

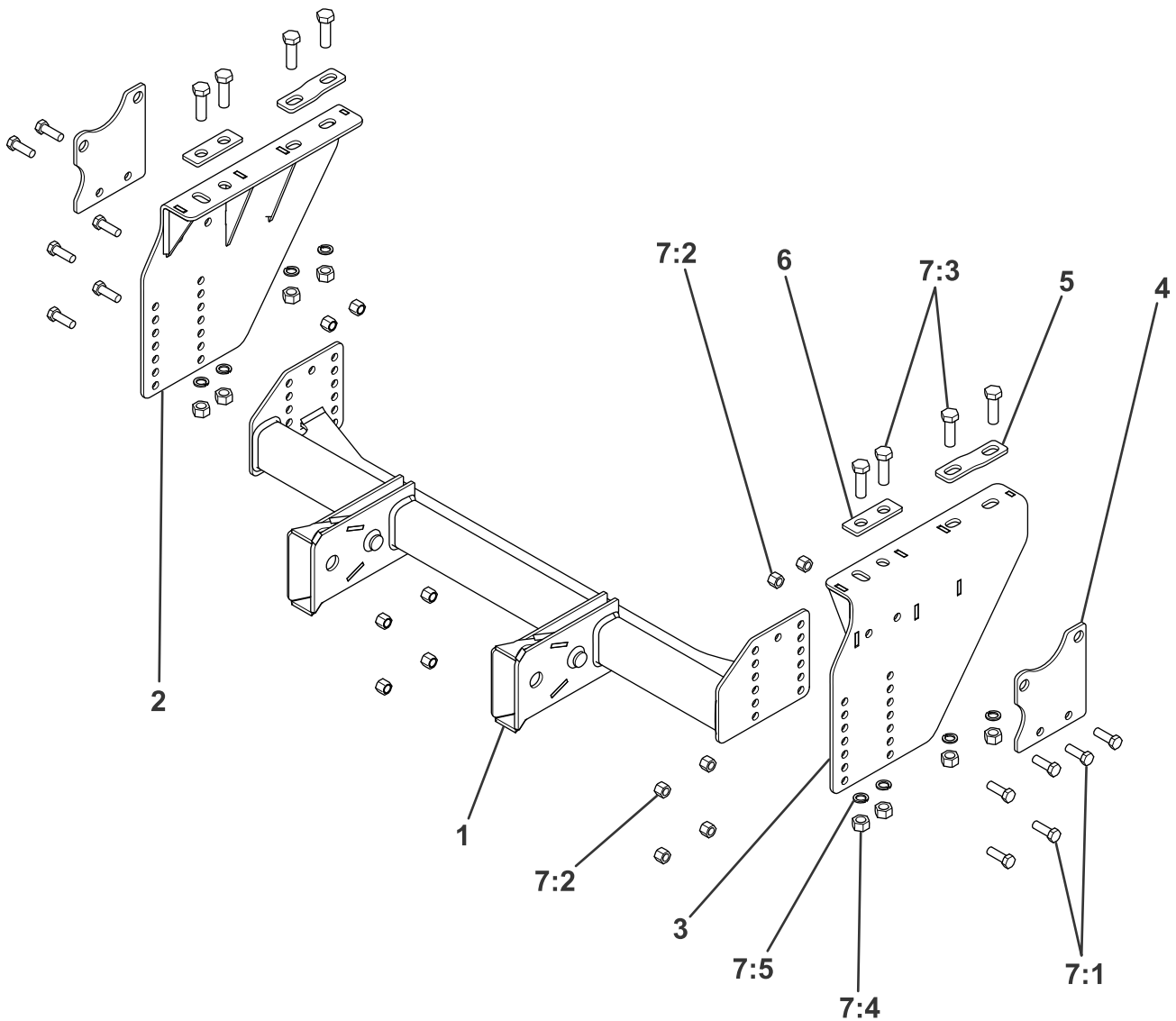

**Parts**

g295478

Ref.	Part Number	Qty.	Description	Ref.	Part Number	Qty.	Description
1	RPL21895-03	1	WLDMNT, PUSHBEAM, DODGE 3500/2500, DRAGPRO	7:1	HDW01728	12	HHCS, 1/2-13 X 1-1/2, NC, GR5, YZN
2	RPL22922-03	1	WLDMNT, SIDEPLATE, DODGE, UC, DS, DRAGPRO	7:2	HDW01748	12	NUT, 1/2-13, NYL INS, YZN
3	RPL22921-03	1	WLDMNT, SIDEPLATE, DODGE, UC, PS, DRAGPRO	7:3	HDW01731	8	HHCS, 5/8-11 X 2, GR5, YZN
4	RPL21905-03	2	SIDE STRAP, DODGE 3500/2500 14+	7:4	HDW01777	8	NUT, 5/8-11, FIN, FULL, YZN
5	RPL22995-03	2	SHIM, UC, DODGE 3/4 T & 1 T, DRAGPRO	7:5	HDW03891	8	WASHER-LOCK, SPLIT, 5/8, YZN
6	RPL22117-03	2	BOLT SHIM, DODGE, UC, DRAG PR				
7	HDW21969	1	KIT-HARDWARE, UC, DODGE 1 T - 3/4 T, DRAGPRO				