



P.O. Box 787  
Iron Mountain, MI 49801  
United States

# Owner's Manual

## Broadcast Spreader Snowrator and Snowrator MAG

Part No. SNR24030—Serial No. 40000000 and Up

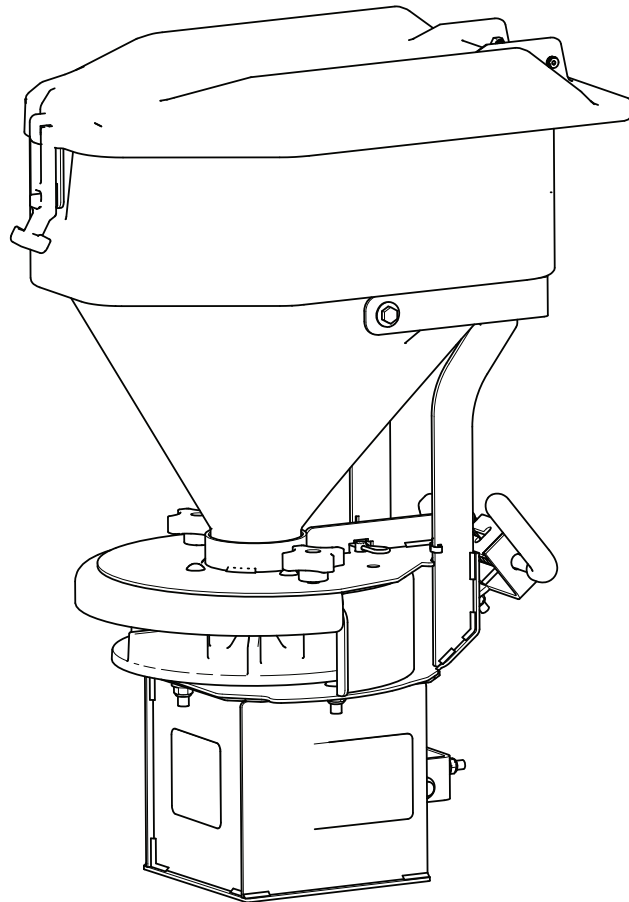

BOSS Products limited consumer warranty and BOSS Products commercial warranty policies are located at [www.bossplow.com](http://www.bossplow.com).

Patent [www.ttcopats.com](http://www.ttcopats.com).

# Introduction

This spreader is designed to dispense ice-control solutions on residential or commercial properties. Using this product for purposes other than its intended use could prove dangerous to you and bystanders.

Read this information carefully to learn how to operate and maintain your product properly and to avoid injury and product damage. You are responsible for operating the product properly and safely.

Visit [www.bossplow.com](http://www.bossplow.com) for product safety and operation training materials, accessory information, help finding a dealer, or to register your product.

Whenever you need service, genuine BOSS parts, or additional information, contact an Authorized BOSS Dealer or BOSS Technical Service (1-800-286-4155) and have the model and serial numbers of your product ready. **Figure 1** identifies the location of the model and serial numbers on the product. Write the numbers in the space provided.

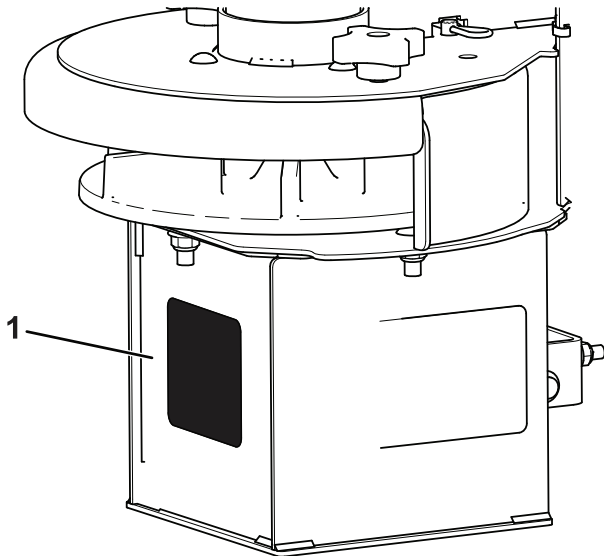

**Figure 1**

g382865

1. Serial number location

Model No. _____
Serial No. _____

The safety-alert symbol shown in this manual and on the machine identifies important safety messages that you must follow to prevent accidents.



**Figure 2**

Safety-alert symbol

g000502

The safety-alert symbol appears above information that alerts you to unsafe actions or situations and is followed by the word **DANGER**, **WARNING**, or **CAUTION**.

**DANGER** indicates an imminently hazardous situation which, if not avoided, will result in death or serious injury.

**WARNING** indicates a potentially hazardous situation which, if not avoided, could result in death or serious injury.

**CAUTION** indicates a potentially hazardous situation which, if not avoided, may result in minor or moderate injury.

This manual uses 2 words to highlight information.

**Important** calls attention to special mechanical information and **Note** emphasizes general information worthy of special attention.

# Contents

Safety .....	3
Preparation.....	3
Operation.....	3
Safety and Instructional Decals .....	4
Setup .....	5
Installing the Mounting Plates .....	5
Installing the Spreader on the Mounting Plates.....	6
Installing the Controller .....	7
Routing the Wire Harness.....	8
Product Overview .....	9
Controls .....	9
Specifications .....	9
Operation .....	10
Removing the Spreader.....	10
Loading the Spreader .....	10
Operating the Spreader .....	10
Freeing a Clog .....	11
Adjusting the Material Deflectors .....	11
Unloading the Spreader.....	11
Cleaning the Spreader.....	11
Troubleshooting .....	12

# Safety

Improperly using and maintaining the equipment can result in injury. To reduce the potential for injury, comply with these safety instructions.

## Preparation

- Ensure that only trained personnel install and perform maintenance on the equipment.
- Always wear appropriate personal protective equipment when loading, unloading, and servicing the spreader. Wear substantial, slip-resistant footwear and eye protection.
- Carefully read and follow the chemical warning labels and safety data sheets (SDSs) for all chemicals used, and protect yourself according to the chemical manufacturer's recommendations.

## Operation

- Read the *Owner's Manual* before operating or servicing the spreader.
- Never put any part of your body between the spreader and the vehicle.
- Overloading the spreader could result in an accident or damage. Never exceed the gross-vehicle-weight rating (GVWR).
- This spreader is restricted to the use of salt only. Do not run other materials through the spreader.
- Do not attempt to mount or remove the spreader with material in it.
- Turn the spreader off before filling, mounting, removing, servicing, or cleaning it.
- Never operate the spreader within 7.6 m (25 ft) of bystanders.
- Do not climb into or ride on the spreader.
- Keep your hands, feet, and clothing away from moving parts and mounting points.
- When transporting the spreader, ensure that it is properly secured. Instructions are available at [www.bossplo.com](http://www.bossplo.com).
- Do not store material in the hopper.

# Safety and Instructional Decals



Safety decals and instructions are easily visible to the operator and are located near any area of potential danger. Replace any decal that is damaged or missing.

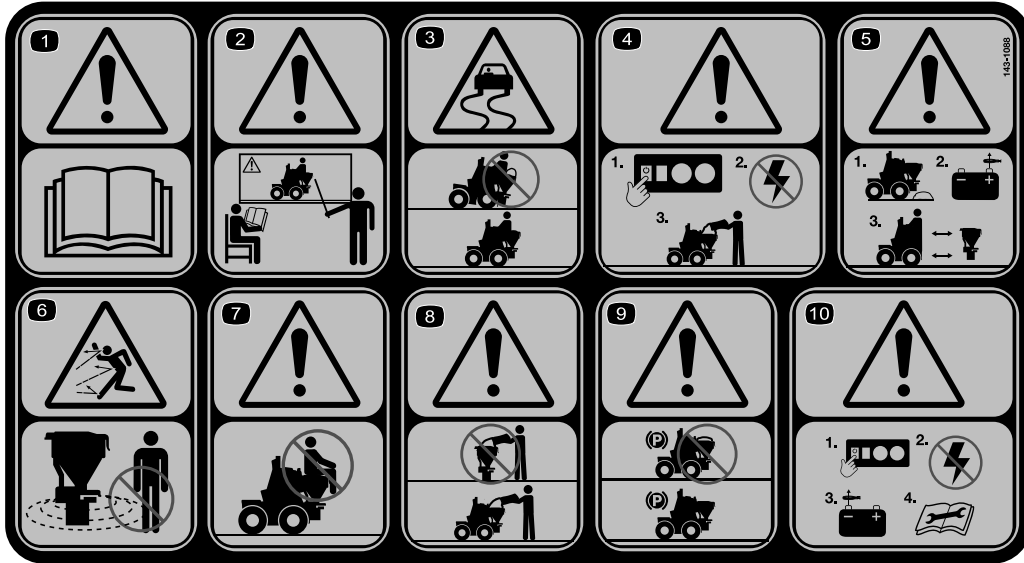

143-1088

decal143-1088

1. Warning—read the *Owner's Manual*.
2. Warning—all operators should be trained before operating the machine.
3. Loss of control hazard—do not overfill the machine.
4. Warning—turn the machine off before filling.
5. Warning—empty the hopper and disconnect the power before installing or removing the machine.
6. Thrown object hazard—keep bystanders away.
7. Warning—do not stand or ride on the machine.
8. Warning—the machine must be installed before filling.
9. Warning—do not store materials in the machine.
10. Warning—turn the machine off and disconnect the power before servicing the machine.

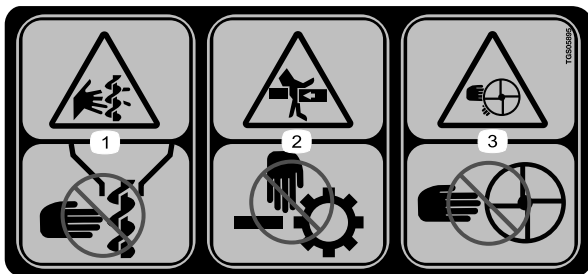

TGS05895

decaltgs05895b

1. Warning—severing of fingers or hand in auger.
2. Warning—fingers or hand entanglement in moving parts.
3. Warning—keep clear of the moving spinner.

# Setup

## Installing the Mounting Plates

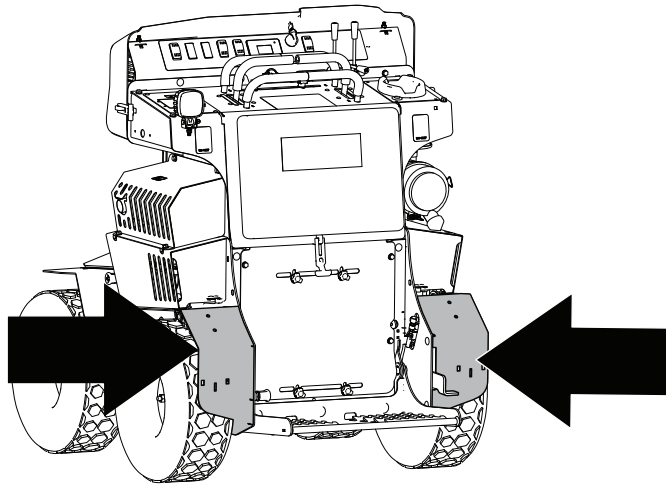

Figure 3

g383799

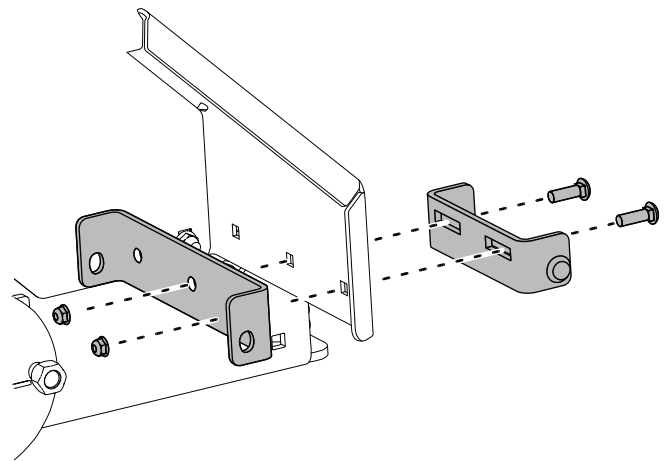

Figure 5  
Snowrator

g382862

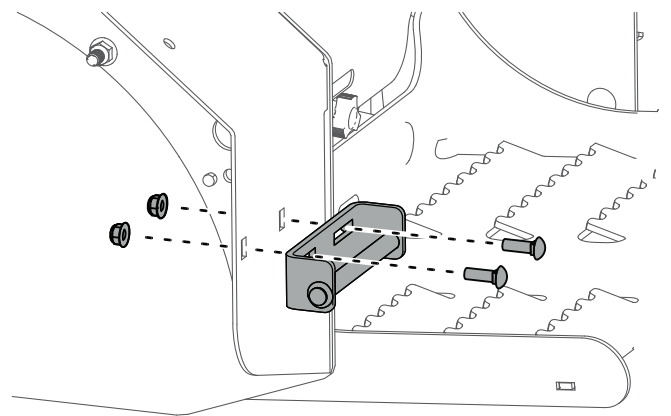

Figure 6  
Snowrator MAG

g387680

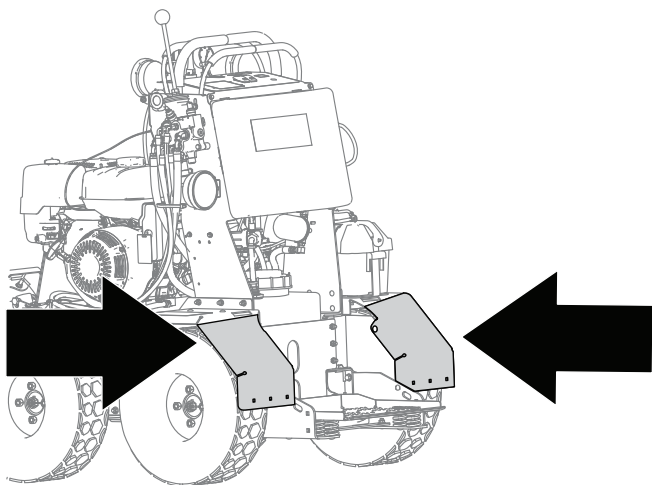

Figure 4

Installation location options

g382858

1. Secure the lower mounting plates to the machine using 2 bolts (5/16-18 x 1 inch) and 2 nuts (5/16-18 inch).

**Important:** Ensure that the mounting bar is below the hardware slots when installing the mounting plates.

- Use both brackets for the Snowrator.
- Use the outer bracket only for the Snowrator MAG.

2. Install the upper mounting bracket using 2 bolts (5/16-18 x 1 inch) and 2 nuts (5/16-18 inch).

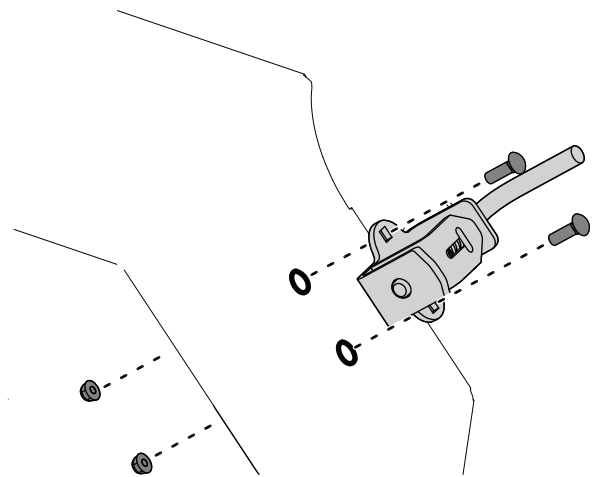

Figure 7

g382867

3. Torque the fasteners to 15 N·m (11 ft-lb).

# Installing the Spreader on the Mounting Plates

1. Place the spreader mounting flange on the mounting bar.

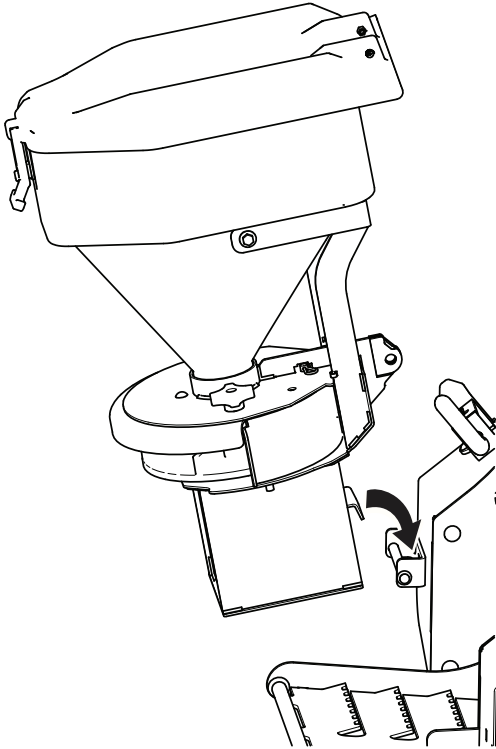

Figure 8

g382863

2. Pull back and lock the latch pin.

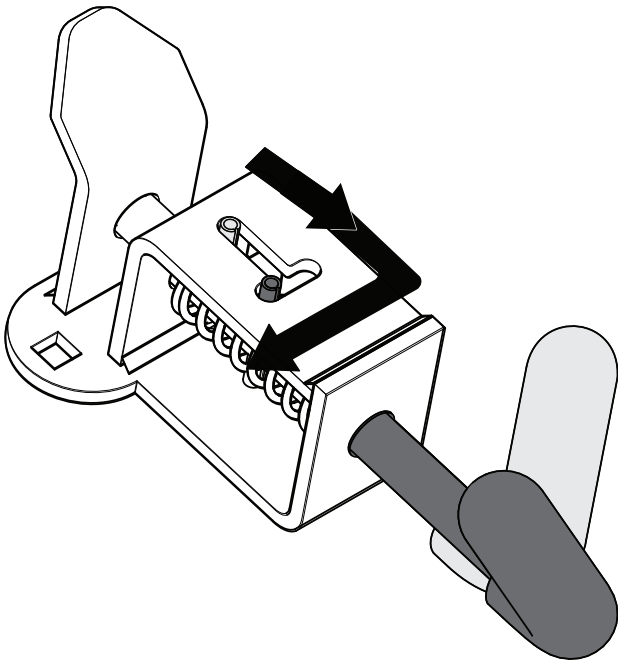

Figure 9

g382866

3. Rotate the spreader upright to the mounting hole and spring bracket. Release the latch pin to secure the assembly.

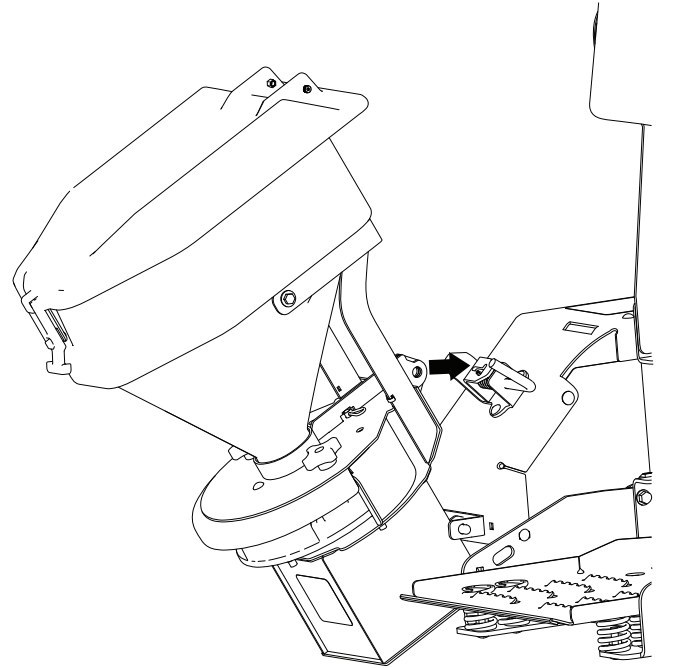

Figure 10

g382859

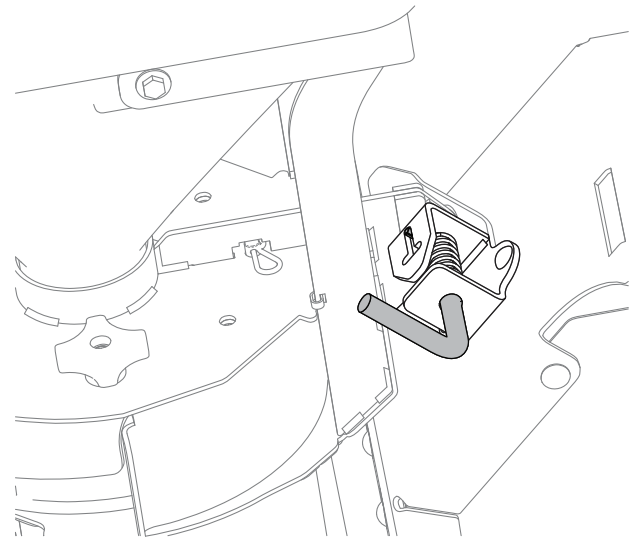

Figure 11

g382860

# Installing the Controller

## Installing the Controller on the Snowrator MAG

1. Remove the cushion from the machine.
2. Remove the knockout panel on the control panel.

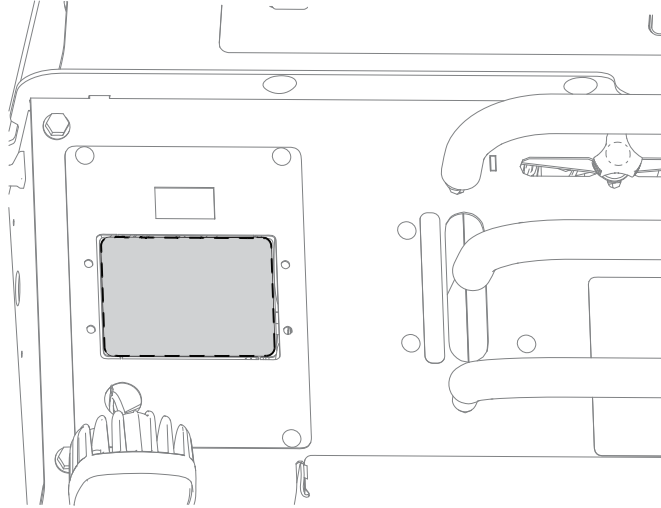

Figure 12

g383797

3. Insert the controller into the opening and secure it with 4 bolts (#10) and nuts.

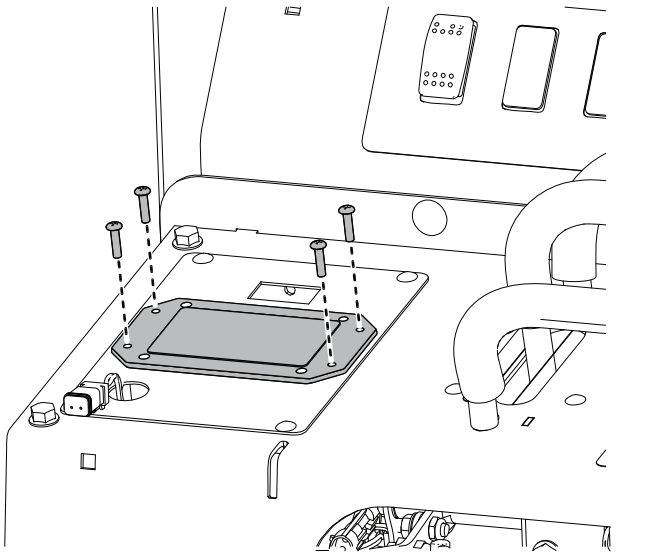

Figure 13

g383796

## Installing the Controller on the Snowrator

1. Remove the cushion from the machine.

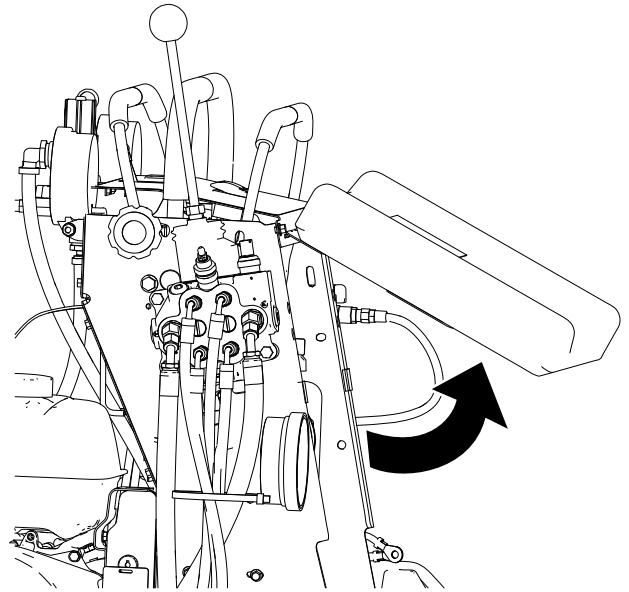

Figure 14

g319131

2. Remove the knockout panel on the control panel.

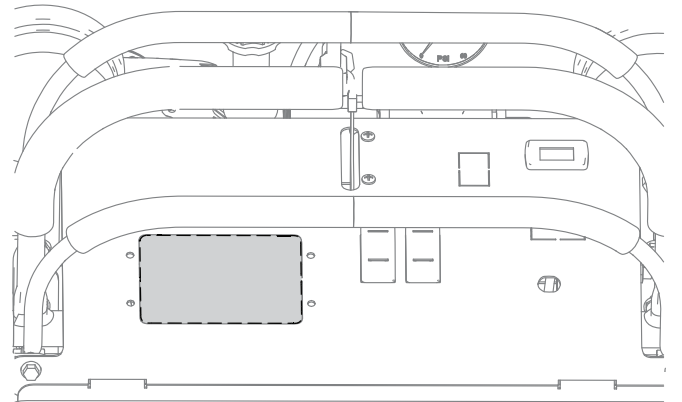
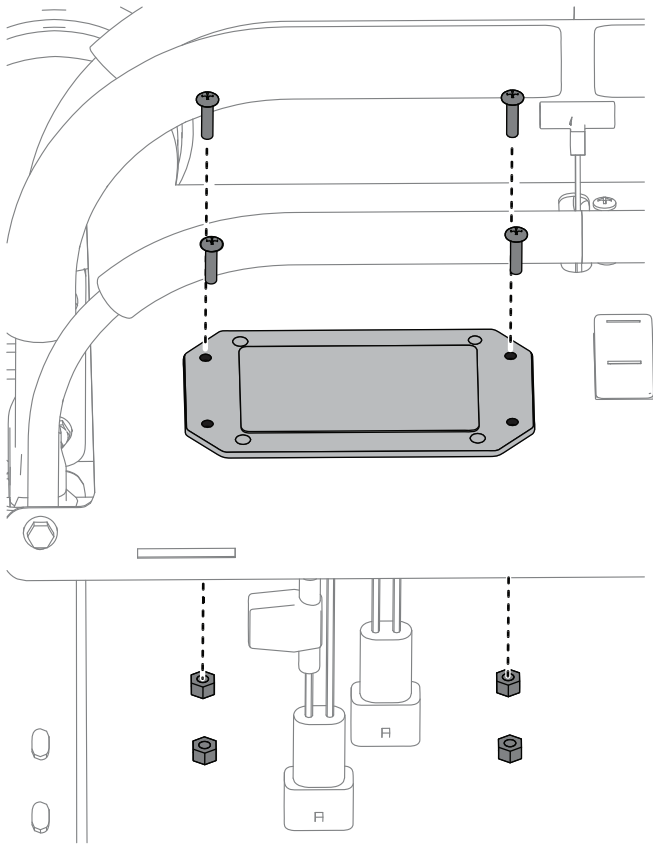

Figure 15

g382864

3. Insert the controller into the opening and secure it with 4 bolts (#10) and nuts.



**Figure 16**

g382856

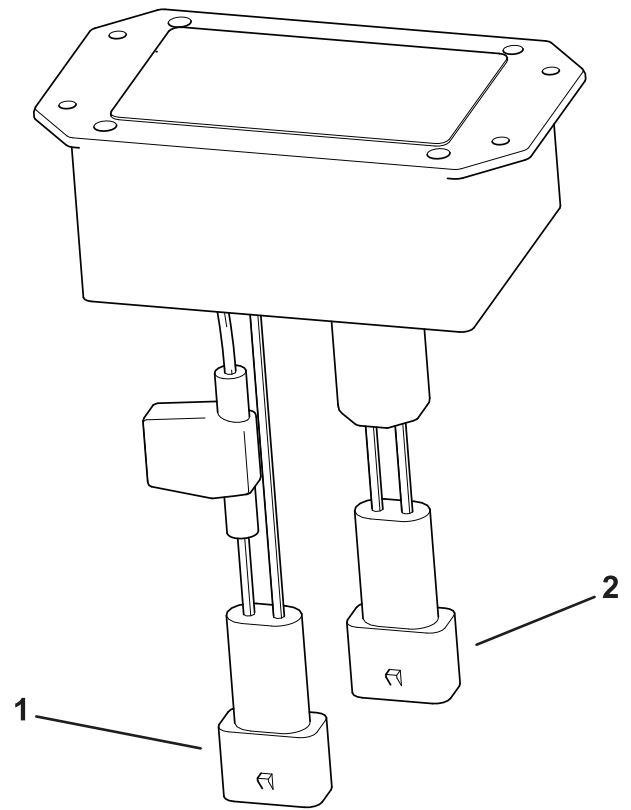

**Figure 17**

g388640

- |                              |                         |
|------------------------------|-------------------------|
| 1. Machine harness connector | 2. Controller connector |
|------------------------------|-------------------------|

## Routing the Wire Harness

**Important:** Keep the harness away from hot or moving parts.

1. Connect the controller connector to the back side of the previously installed control and secure with cable ties.
2. Connect the spreader side harness to the spreader connector. Route this harness over the fender near the spreader latch pin.
3. Secure any excess wires with cable ties.



# Product Overview

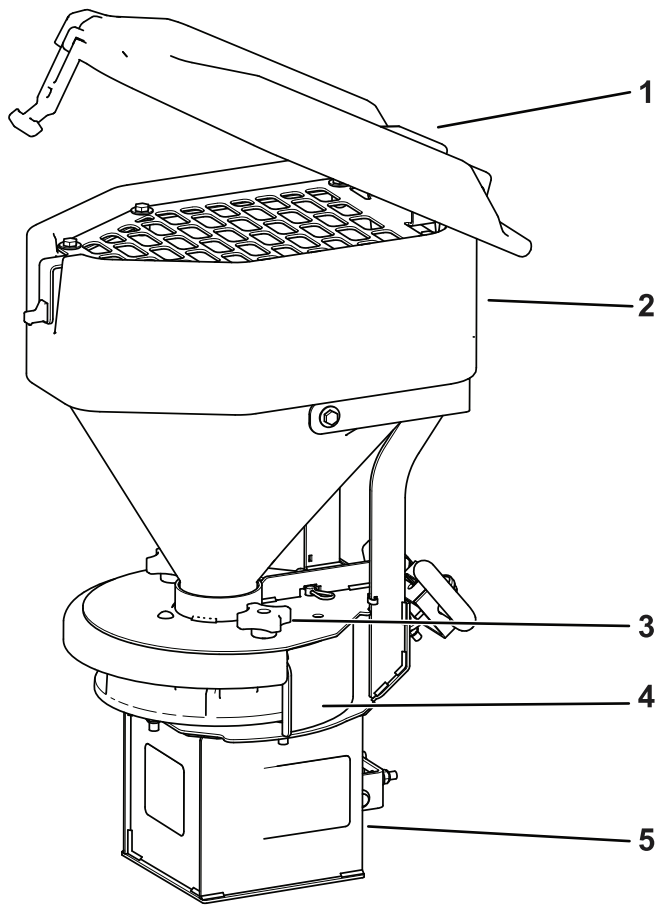

**Figure 18**

g382943

1. Lid
2. Hopper
3. Material deflector adjustment knob
4. Material deflector
5. Motor box

## Controls

Become familiar with all of the controls before you operate the spreader.

### Material Deflector

The material deflector controls the spread of materials; you can adjust the controls to provide different spread patterns; refer to [Adjusting the Material Deflectors \(page 11\)](#)

## Controller

The spreader controller lets you operate your spreader and displays information about your machine.

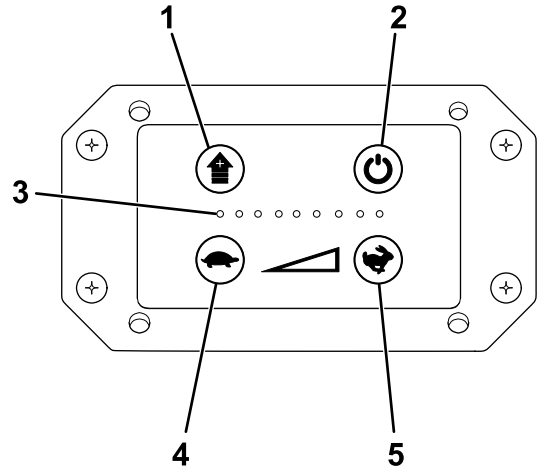

**Figure 19**

g293836

1. Blast button
2. Power button
3. Speed LED's
4. Slow button
5. Fast button

- Power button—turns the spreader controller and spinner motor on or off. Press once to turn the controller on. Press again to turn the spinner motor on or off. Hold the button to turn the controller off.
- Blast button—momentarily sends full power to the spinner motor as long as it is held
- Fast button—increases the spinner motor speed
- Slow button—decreases the spinner motor speed
- Speed LED's—indicates the spinner motor speed and operating mode.

## Specifications

**Note:** Specifications and design are subject to change without notice.

Height	73.6 cm (28-32 inches)
Width	31.75 cm (12.5 inches)
Depth	51.4 cm (20.25 inches)
Weight (empty)	22.7 kg (50 lb)
Capacity	0.024 m <sup>3</sup> (0.85 ft <sup>3</sup> )

# Operation

**Note:** Determine the left and right sides of the machine from the normal operating position.

## **⚠ DANGER**

The spreader is heavy and could cause serious injury or property damage if it falls off the vehicle.

- Ensure that your footing is stable, and avoid lifting the spreader on slippery or uneven surfaces.

## Removing the Spreader

1. Disconnect the spreader wire harness.
2. Ensure that all material has been emptied from the spreader.
3. Pull back and lock the latch pin.

**Important:** Hold the spreader in place when unlocking the latch pin.

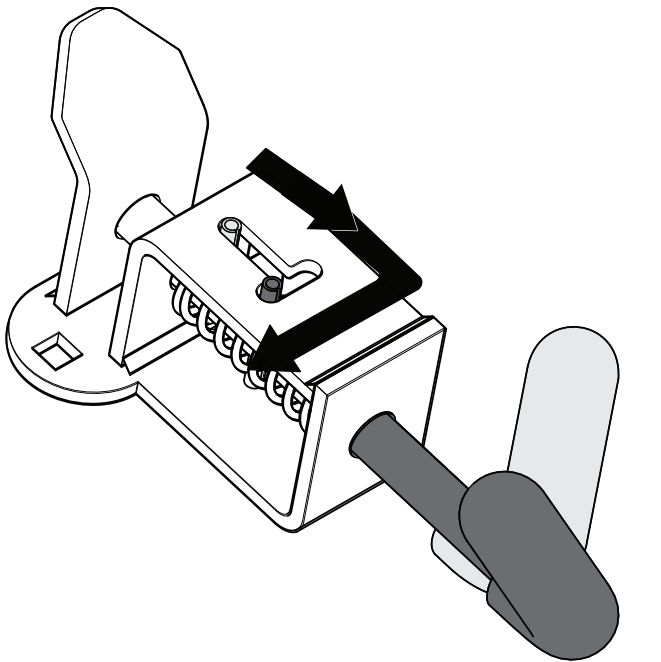

Figure 20

g382866

4. Rotate the spreader back and lift the spreader mounting flange off of the mounting bar.

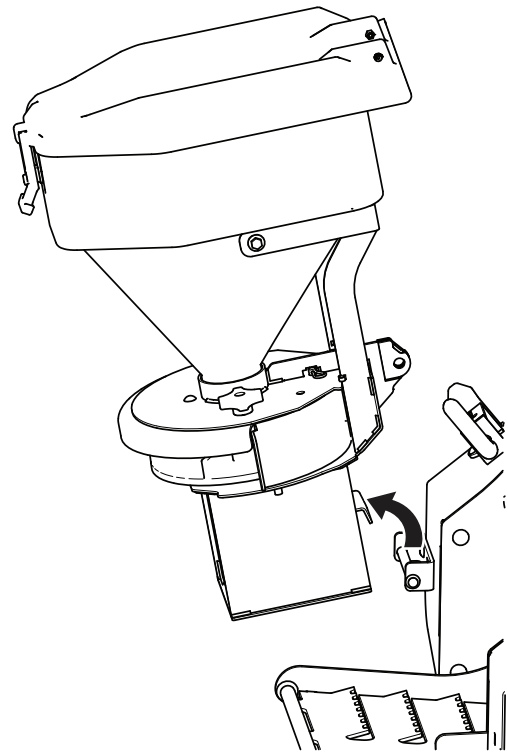

Figure 21

g382945

## Loading the Spreader

**Important:** Use only bag or bulk salt in the spreader. Other materials could cause damage to the machine.

1. Ensure that the spreader is securely mounted to your machine and is not over slippery or uneven terrain.
  2. Open the hopper cover.
  3. Determine the amount of material that you can safely transport in your spreader; refer to [Specifications \(page 9\)](#).
  4. Place the bag of material on the edge of the hopper and open the top. Carefully pour the contents into the hopper.
- Note:** Have 2 people lift bags weighing more than 18 kg (40 lb).
5. Close and secure the hopper cover.

## Operating the Spreader

1. Start the machine.
2. Turn on the spreader.
3. Set your desired spinner motor speed.

**Note:** The spinner motor speed determines how far and how densely the material is spread.

Slow speeds spread material close and densely.  
Fast speeds spread material far and thinly.

4. Drive at a consistent speed as you spread material.
5. When you are finished spreading, turn the spreader off.

## Freeing a Clog

If the clog is not cleared automatically, turn off the machine, disconnect the spreader wire harness, and manually free the clog.

## Adjusting the Material Deflectors

1. Turn the material deflector knob counter clockwise to loosen the material deflector.
2. Slide the material deflector into the desired position.
3. Turn the material deflector knob clockwise to tighten the material deflector.

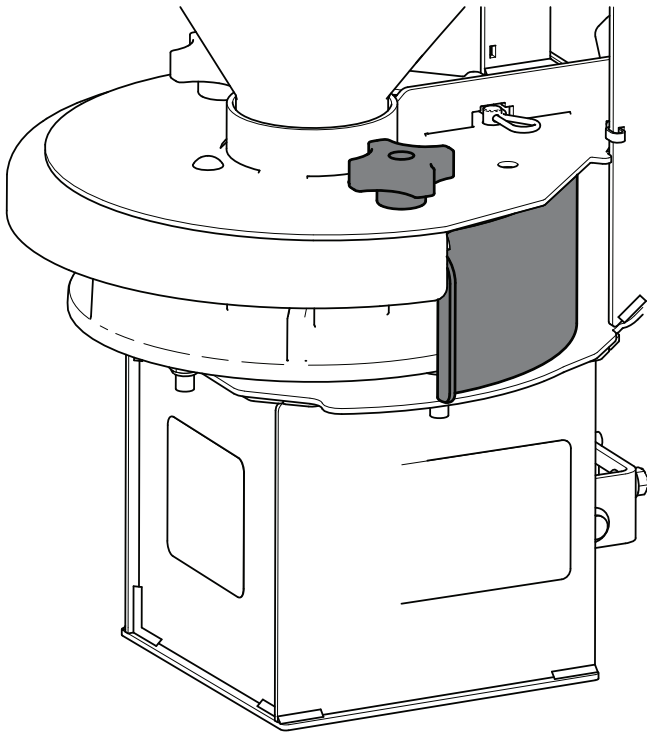

Figure 22

g382948

## Cleaning the Spreader

**Service Interval:** Before each use or daily—Clean the spreader.

**Important:** Do not use water to clean the spreader.

Use compressed air to clear debris and materials from the spreader and hopper.

## Unloading the Spreader

1. Position the spreader in the area where you want to deposit the material.
2. Turn on the spreader controller and run the spreader until the hopper is empty.

# Troubleshooting

Problem	Possible Cause	Corrective Action
The controller has no power.	<ol style="list-style-type: none"> <li>1. The controller is not plugged into the wire harness.</li> <li>2. The electrical system is damaged.</li> <li>3. A fuse is blown.</li> </ol>	<ol style="list-style-type: none"> <li>1. Plug in the controller.</li> <li>2. Contact your authorized BOSS dealer.</li> <li>3. Replace the fuse.</li> </ol>
The spreader motor does not work.	<ol style="list-style-type: none"> <li>1. The spreader and vehicle wire harnesses are not connected.</li> <li>2. The controller is not plugged into the wire harness.</li> </ol>	<ol style="list-style-type: none"> <li>1. Connect the wire harnesses.</li> <li>2. Plug in the controller.</li> </ol>
Material is spreading too fast.	<ol style="list-style-type: none"> <li>1. The feed gate is open too much.</li> </ol>	<ol style="list-style-type: none"> <li>1. Move the feed gate lever to the appropriate setting.</li> </ol>
2 LED's on the controller are flashing.	<ol style="list-style-type: none"> <li>1. The spinner disk is stuck.</li> <li>2. The spinner shaft is bent.</li> <li>3. The spinner disk is contacting the material deflector.</li> </ol>	<ol style="list-style-type: none"> <li>1. Refer to the Freeing a Clog section.</li> <li>2. Inspect the spinner shaft and replace it if damaged.</li> <li>3. Clean off the material deflector.</li> </ol>
3 LED's on the controller are flashing.	<ol style="list-style-type: none"> <li>1. There is a short between the controller and the spreader.</li> <li>2. The spinner motor has an internal short.</li> </ol>	<ol style="list-style-type: none"> <li>1. Check the wire harness between the spreader and controller. Repair or replace it if damaged.</li> <li>2. Replace the spinner motor.</li> </ol>
4 LED's on the controller are flashing.	<ol style="list-style-type: none"> <li>1. The spreader is not connected to the controller.</li> <li>2. The connection between the spreader and controller connectors is bad.</li> <li>3. The spreader or controller are connected to the wrong wire harness connectors.</li> </ol>	<ol style="list-style-type: none"> <li>1. Connect the spreader to the controller.</li> <li>2. Clean the connectors.</li> <li>3. Ensure that the spreader and controller are connected to the correct wire harness connectors.</li> </ol>
5 LED's on the controller are flashing.	<ol style="list-style-type: none"> <li>1. The battery voltage is low.</li> </ol>	<ol style="list-style-type: none"> <li>1. Increase the engine rpm and turn the controller off then on again. If the problem persists, turn off the vehicle pump, lights, vibrator, and spreader, increase the engine rpm, and let the machine run for several minutes. Check the voltage until your volt meter reads 12 V, then turn the controller off then on again.</li> </ol>
6 LED's on the controller are flashing.	<ol style="list-style-type: none"> <li>1. The voltage regulator is bad.</li> </ol>	<ol style="list-style-type: none"> <li>1. Replace the voltage regulator.</li> </ol>
7 LED's on the controller are flashing.	<ol style="list-style-type: none"> <li>1. The controller is overheating.</li> </ol>	<ol style="list-style-type: none"> <li>1. Turn the controller off until it cools down.</li> </ol>