

Vehicle Headlight Module Wiring Kit

2025 and After Ram 1500 (DT) with LED Headlights, 2021 and After Ford F-150 with LED Headlights, and 2022 and After Toyota Tundra

Part No. MSC25011

Installation Instructions

Safety

⚠ WARNING

Incorrect battery cable routing could damage the machine and cables, causing sparks. Sparks can cause the battery gases to explode, resulting in personal injury.

- Always disconnect the negative (black) battery cable before disconnecting the positive (red) cable.
- Always connect the positive (red) battery cable before connecting the negative (black) cable.

Installation

Determine the left and right sides of the machine from the normal operating position.

Installing the Kit

Installing the Wiring Kit for All Vehicles

1. Park the vehicle on a level surface.
2. Engage the parking brake.
3. Shut off the engine, remove the key, wait for all moving parts to stop, and allow the vehicle to cool.
4. Disconnect the battery.
5. Ensure that the vehicle firewall is clear of obstructions.

⚠ WARNING

Using a drill without wearing eye protection may allow debris to enter the eye, causing personal injury.

When drilling, always wear eye protection.

6. Drill a 3 cm (1-1/4 inch) diameter hole through the firewall on the driver side of the vehicle.

Note: The hole should be in an easily accessible area.

7. Insert the split rubber grommet into the hole.
8. Pull the plow controller connector and module connector (10-pin Molex Minifit) into the vehicle cab through the hole in the firewall ([Figure 1](#)).

Important: Ensure that all wiring is secured in a position that avoids hot or moving parts to prevent damage to the vehicle or plow.



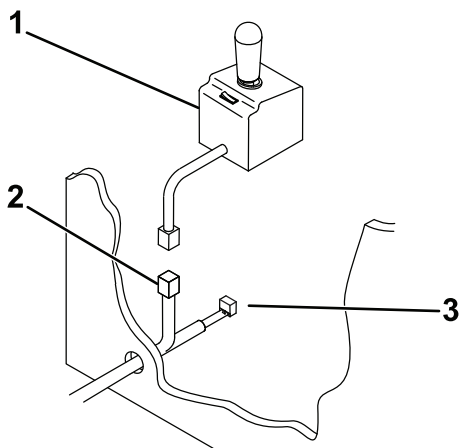

Figure 1

g368875

- | | |
|-------------------------|------------------------------|
| 1. Plow controller | 3. Module connector (10-pin) |
| 2. Controller connector | |

9. Plug the controller connector into the plow controller.
10. Mount the plow controller.
11. Connect the white/black wire from the wire harness to the small post on the pump solenoid (Figure 2).

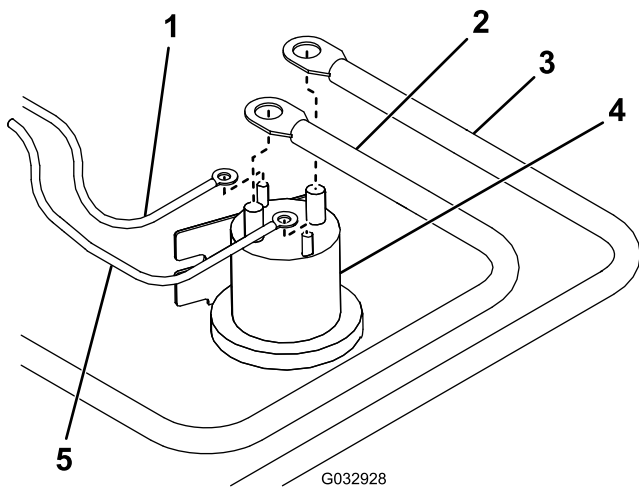

Figure 2

G032928

g032928

- | | |
|---------------------------|------------------|
| 1. White/black wire | 4. Pump solenoid |
| 2. Battery cable | 5. Brown wire |
| 3. Red power/ground cable | |

12. Connect the brown wire from the wire harness to the other small post on the pump solenoid (Figure 2).

Note: The wires may go on either small post, but should not share a post.

13. Mount the pump solenoid inside the engine compartment of the vehicle, ensuring that it stays in an upright position and does not contact

the body, hood, or other conductive material on the vehicle.

14. Connect the red power/ground cable to the large post on the pump solenoid (Figure 2).
15. Connect the battery cable to the other large post on the pump solenoid (Figure 2).

Note: The wires may go on either large post, but should not share a post.

16. Connect the black power/ground cable:
 - For Ford vehicles—connect the black power/ground cable to the passenger side fender ground stud.
 - For Ram vehicles—connect the black power/ground cable to the engine block.
 - For Toyota vehicles—connect the black power/ground cable to the negative battery terminal.

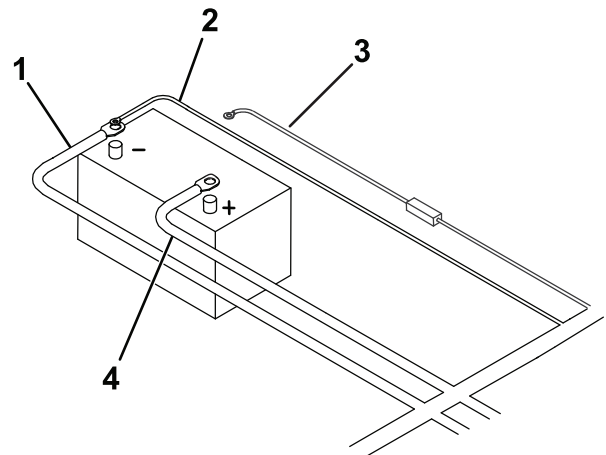

Figure 3

g369226

- | | |
|-----------------------------|---------------------------|
| 1. Black power/ground cable | 3. Red/white fused wire |
| 2. Brown wire | 4. Red power/ground cable |

17. Connect the brown wire:
 - For Ford vehicles—connect the brown wire to the passenger side fender ground stud.
 - For Ram vehicles—connect the brown wire to the engine block.
 - For Toyota vehicles—connect the brown wire to the negative battery terminal.

18. Connect the free end of the battery cable to the positive (+) battery terminal (Figure 3).

19. Connect the red/white fused wire to the positive (+) battery terminal (Figure 3).

20. Mount the truck side, wire harness plow connector to the lower part of the bumper using the control harness mounting bracket (Figure 4).

Installing the Vehicle Headlight Module and Wiring Kit for Ford F150 Vehicles

1. Remove the trim on top of the display using a plastic trim tool.

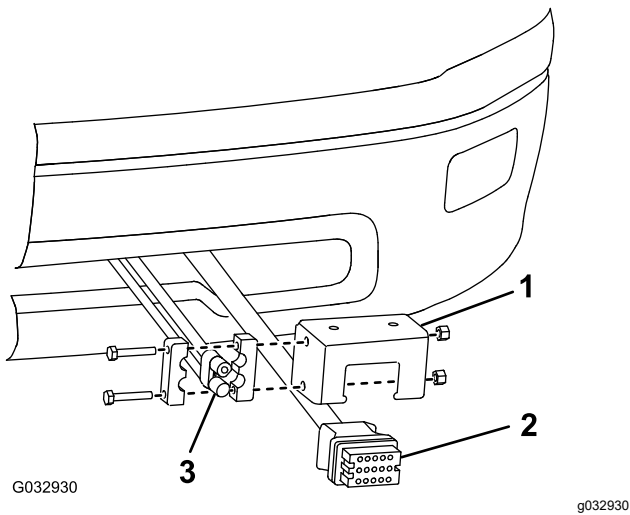

Figure 4

1. Control-harness mounting bracket
2. Plow connector
3. Power/ground connector bracket

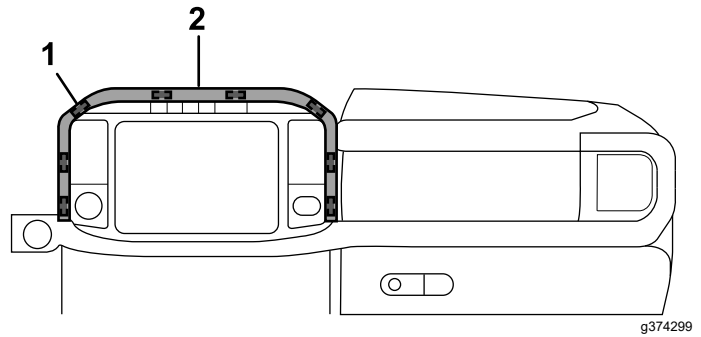

Figure 6

1. Clips (8)
2. Top trim

21. Mount the black and red power/ground connector to the control harness mounting bracket (Figure 4).
22. Mount the relay pack to the inside of the engine compartment using a sheet-metal screw.

Note: Ensure that the relay pack is mounted in the upright position.

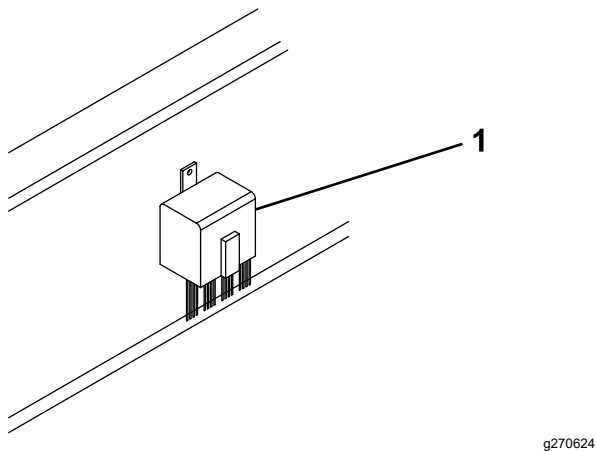

Figure 5

1. Relay pack

2. Remove the center trim.

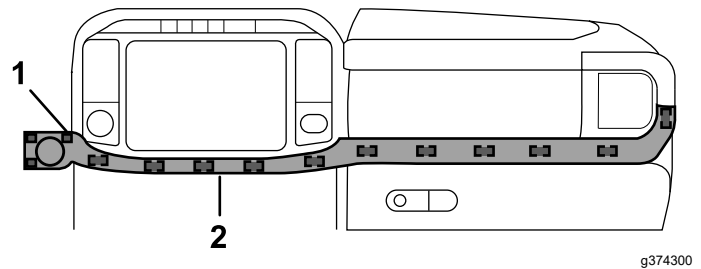

Figure 7

1. Clips (14)
2. Center trim

3. Pull down to open the trim panel beneath the steering column.

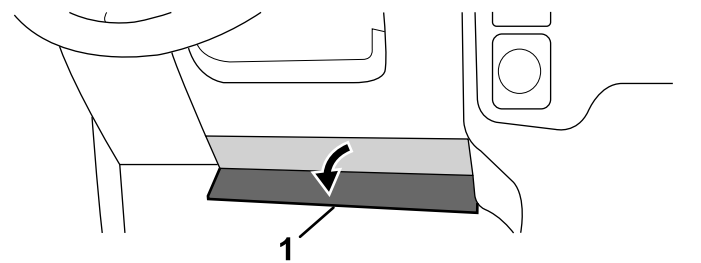

Figure 8

1. Trim panel

4. Remove the 2 bolts and steering column trim.

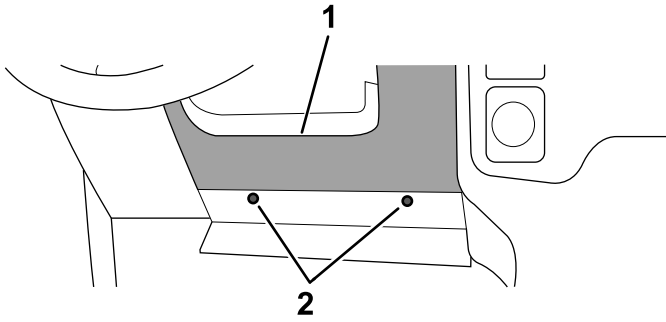

Figure 9

g368121

1. Steering column trim 2. Bolts

5. Remove the trim on the left and right sides of the center console.

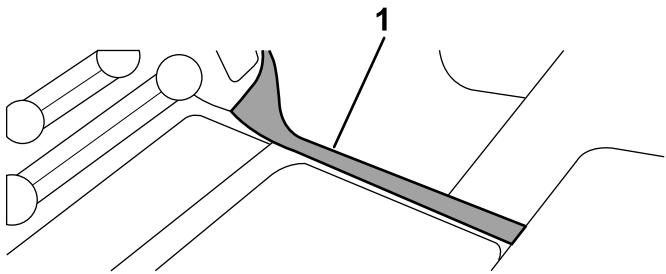

Figure 10

g368123

1. Side panel

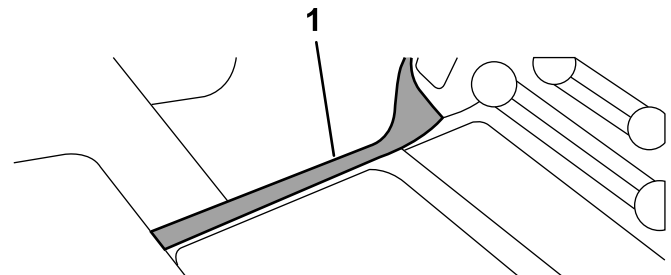

Figure 11

g368124

1. Side panel

6. Remove the bolts securing the lower center stack control panel located beneath the display screen.

7. Remove lower center stack control panel and disconnect the wiring.

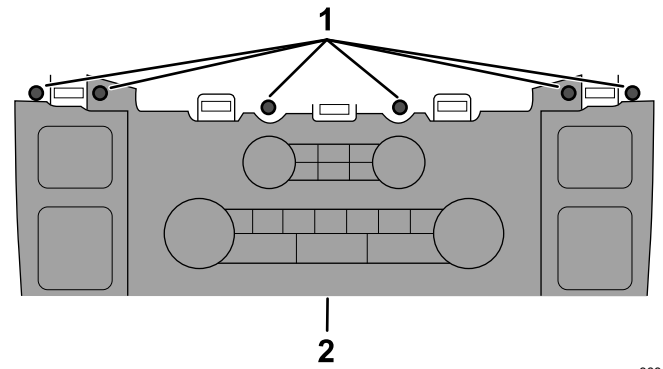

Figure 12

g368122

1. Bolts 2. Control panel

8. Remove the bolts on the module bracket.

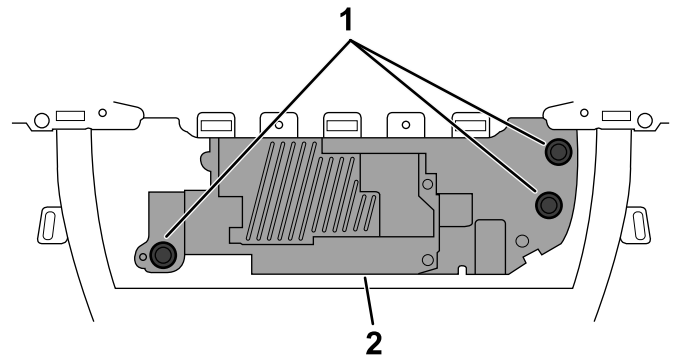

Figure 13

g368125

1. Bolts 2. Module

9. Locate the OEM 26-pin connector and disconnect it from the gateway module.

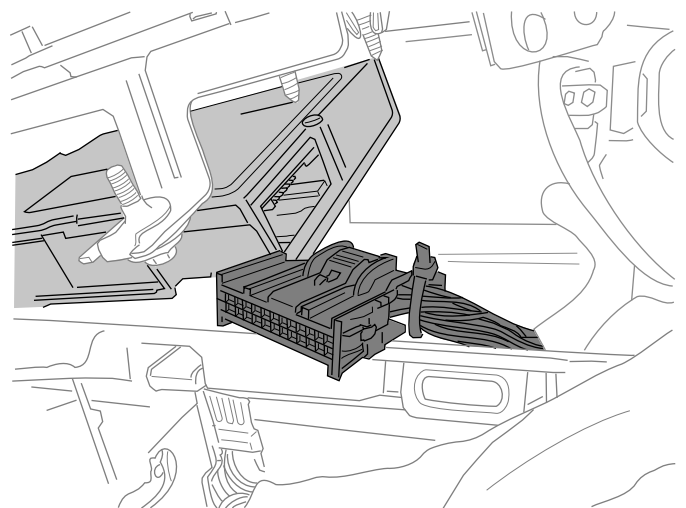

Figure 14

g368630

10. Plug the 26-pin connector (black) from the supplied datalink harness into the mating connector on the OEM Gateway module.

11. Locate the 26-pin connector that was originally connected to the OEM Gateway module, and plug it into the mating connector on the datalink harness.
12. Secure the cables with a cable tie.
13. Route the opposite end of the data link harness (6-pin connector) behind the console, under the dash, near the gas and brake pedals.
14. Check to see if your vehicle is compatible with the module; refer to [Initializing the Vehicle Headlight Module \(page 8\)](#).
15. Once the VHM has been initialized, plug in the 10-pin connector from the BOSS vehicle side harness that was routed through the firewall into the VHM module.

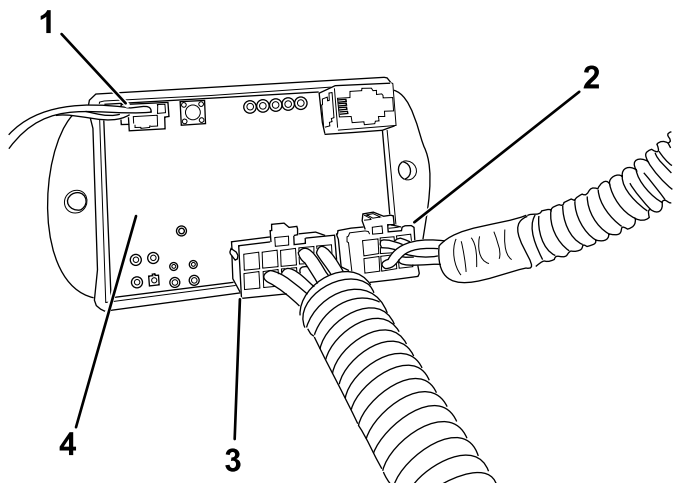

Figure 15

g371856

- | | |
|---------------------------------|-----------------------------------|
| 1. Highbeam indicator connector | 3. 10-pin connector |
| 2. 6-pin connector | 4. VHM (vehicle headlight module) |

16. Route the highbeam indicator connector from the dash to the VHM module and plug it in.
17. Mount the highbeam indicator to the instrument cluster, using double sided tape, so that this is visible to the driver.
18. Install the trim onto the vehicle.
19. Secure the VHM module and wire harness under the dash.

Installing the Vehicle Headlight Module and Wiring Kit for 2019 through 2024 Ram Vehicles

1. Locate and remove the white 16-pin OBDII data link connector under the left side of the steering column.
2. Plug the red connector from the data link harness into the OBDII connector.
3. Mount the white connector, from the VHM data link harness, under the left side of the steering column where you removed the OBDII connector.
4. Locate the STAR connector bank, with the black base, next to the parking brake.

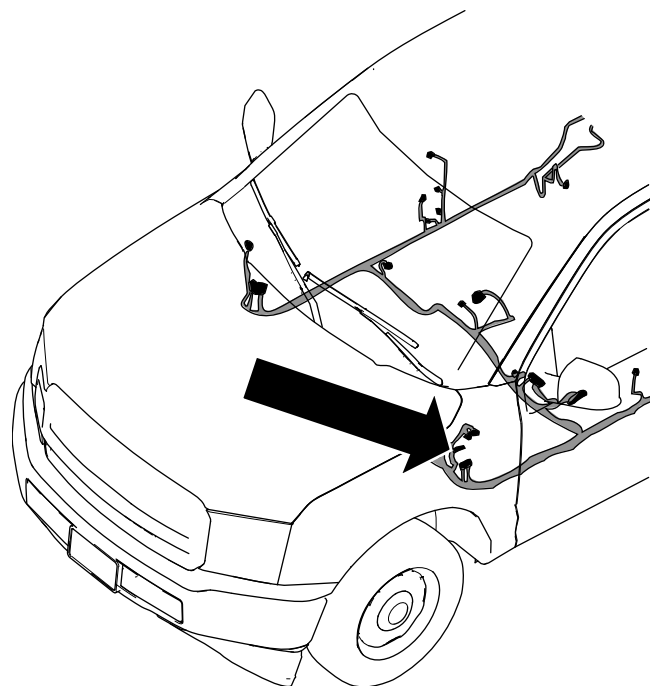
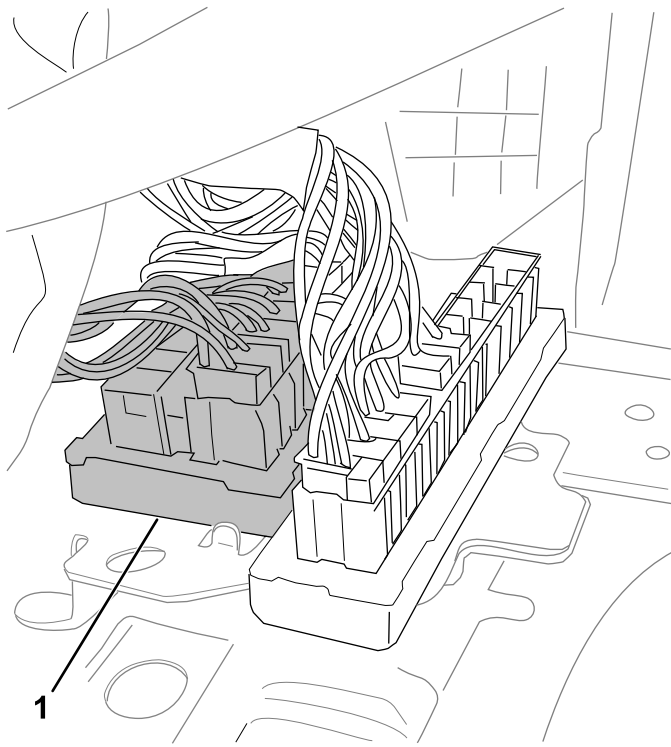

Figure 16

g374297

5. Plug the 2-pin data link harness connector with the yellow and brown wires into any of the unused port on the STAR connector bank with the black base.



g374404

Figure 17

1. STAR connector bank

Installing the Vehicle Headlight Module and Wiring Kit for 2025 and after Ram Vehicles

1. Remove the passenger-side dash lower trim panel located below the glove box.
2. Remove the glove box.
3. Remove the front passenger side door sill trim panel.
4. Remove the bolt on the bottom right of the bracket and pull the top right corner to release the white pin.
5. Locate the gray connector behind the module and bracket. Plug the mating ends of the VHM data link harness to the factory connectors.
6. Connect the ring terminal on the black wire from the VHM data link harness to the bare metal connection on the chassis.

Note: One possible location is a stud below the gray connector under the carpet.

Installing the Vehicle Headlight Module and Wiring Kit for Toyota Tundra Vehicles

1. Pull the panel from the left side of the dash and locate the row of white connectors.

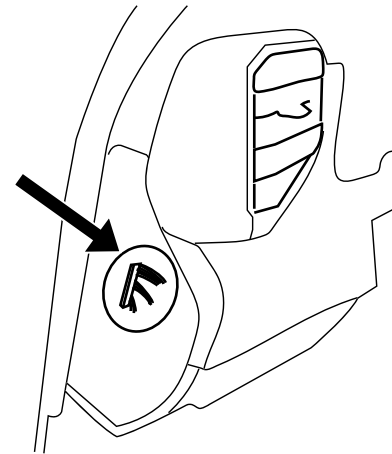

g418295

Figure 18

2. Locate the white 30-pin connector at the top of the row of connectors and remove it ([Figure 19](#)).
3. Locate the black wire in pin #1 and the white wire in pin #2 of the connector ([Figure 19](#)).

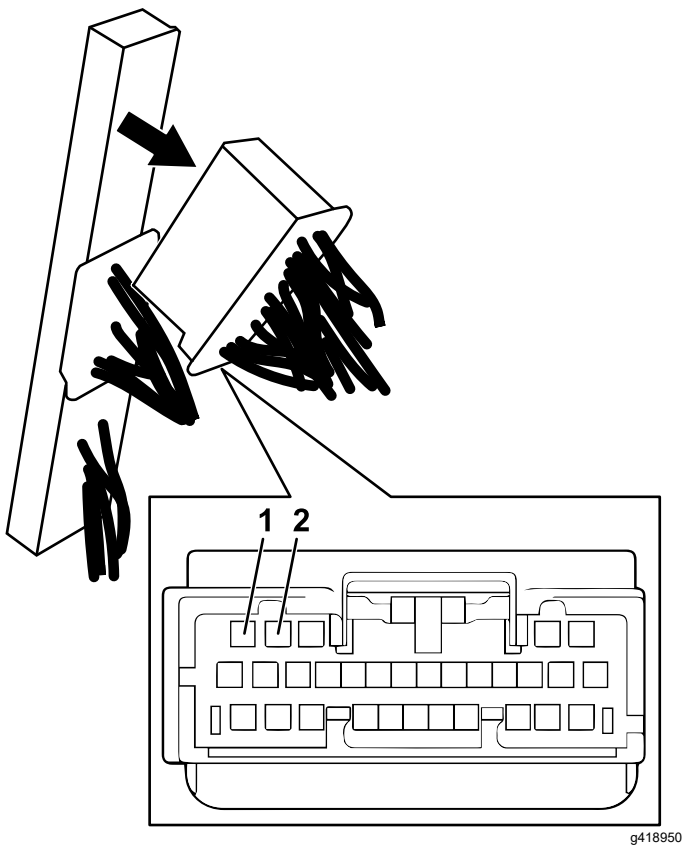

Figure 19

1. Pin #1

2. Pin #2

4. Attach the black wire from the VHM harness and connect it to the black wire in pin #1 of the 30-pin connector using the provided Posi-Tap.
5. Attach the white wire on the VHM harness and connect it to the white wire in pin #2 of the 30-pin connector using the provided Posi-Tap.
6. Locate the white OEM OBD-II connector under the dash and release it from the dash panel by pressing in on the two tabs located on the side of the connector. Push it up through the dash and locate it near the previously Posi-Tapped wires.

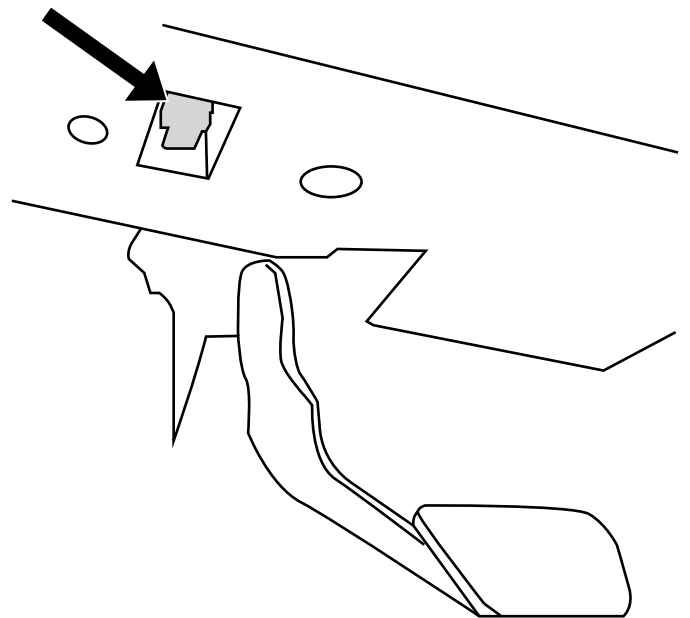

Figure 20

7. Plug the red connector from the VHM harness into the vehicle's OBD-II connector. Ensure the connection is fully seated and secure with the supplied wire tie.
8. Mount the white pass-thru connector from the VHM harness in the former location of the vehicle's OBD-II connector.
9. Plug the 6-pin connector in the VHM module.

Initializing the Vehicle Headlight Module

Turn the vehicle key to the ON position.

Plug the other end of the data link harness into the 6-pin connector on the VHM module

Note: The VHM initialization process requires the key to be in the ON position before the connectors are plugged into the VHM module.

The vehicle headlight module (VHM) reads the VIN to verify the vehicle make, model, model year, and engine type and verifies compatibility.

If the VIN is accepted, all of the LED lights on the VHM will illuminate green for 3 seconds.

If the VIN is not accepted, all of the LED lights on the VHM will cycle, momentarily stopping on a corresponding LED, indicating an error with the following:

- LED 1—vehicle manufacturer
- LED 2—vehicle model
- LED 3—vehicle engine type
- LED 4—vehicle model year

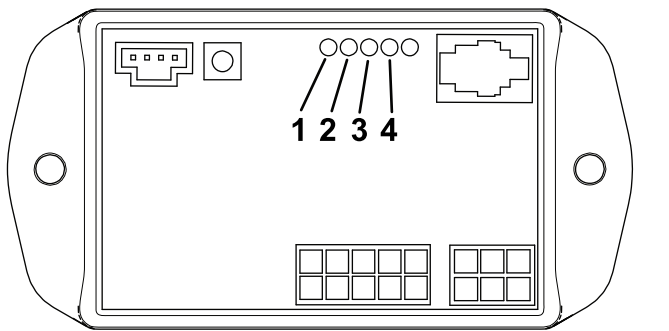

Figure 21

- | | |
|-------------------------|------------------------|
| 1. LED 1 (manufacturer) | 3. LED 3 (engine type) |
| 2. LED 2 (model) | 4. LED 4 (model year) |

Ensure that all connections are correct when the VIN is not accepted.

The vehicle may not be compatible with the device if all connections are correct and the device does not recognize the VIN.

Operation

To turn the plow lights on, put the vehicle headlight switch to the PARK light position.

To turn the plow lights off, put the vehicle headlight switch to the AUTO/OFF position.

Ford F-150 Installation

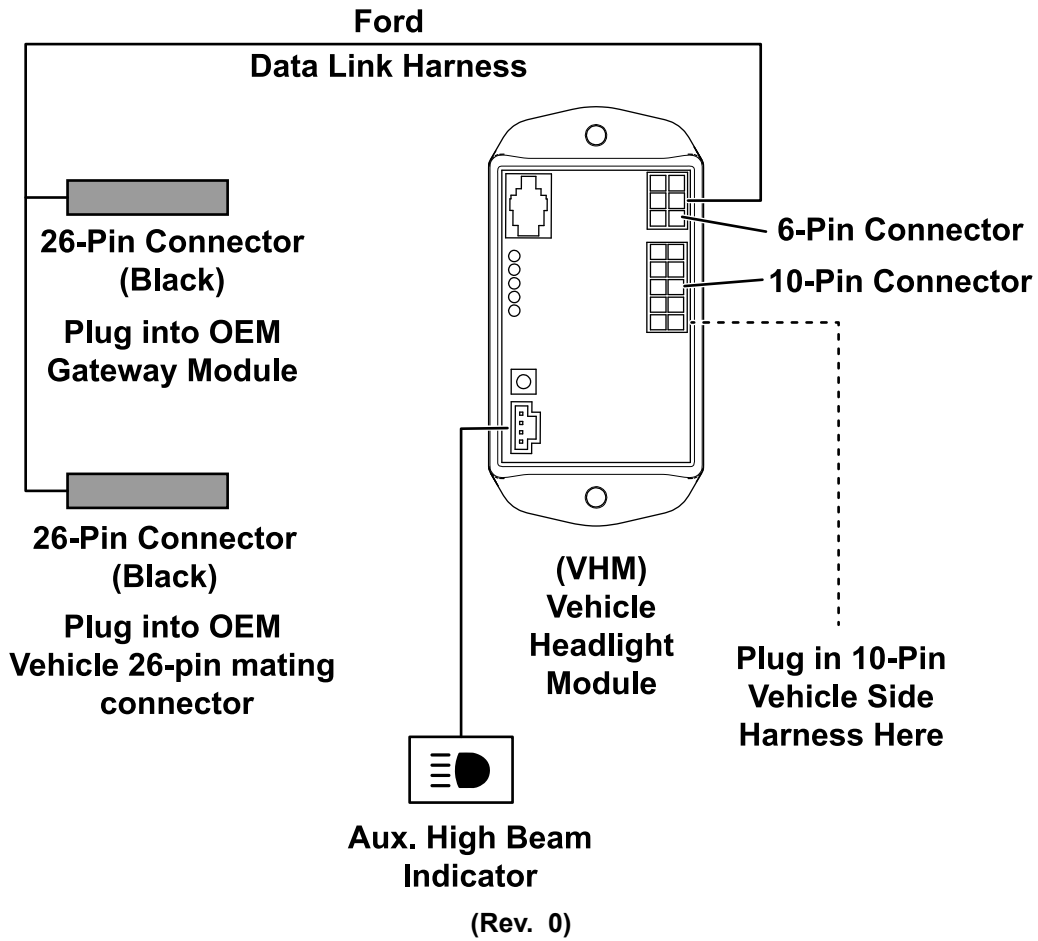

RAM 1500 Installation

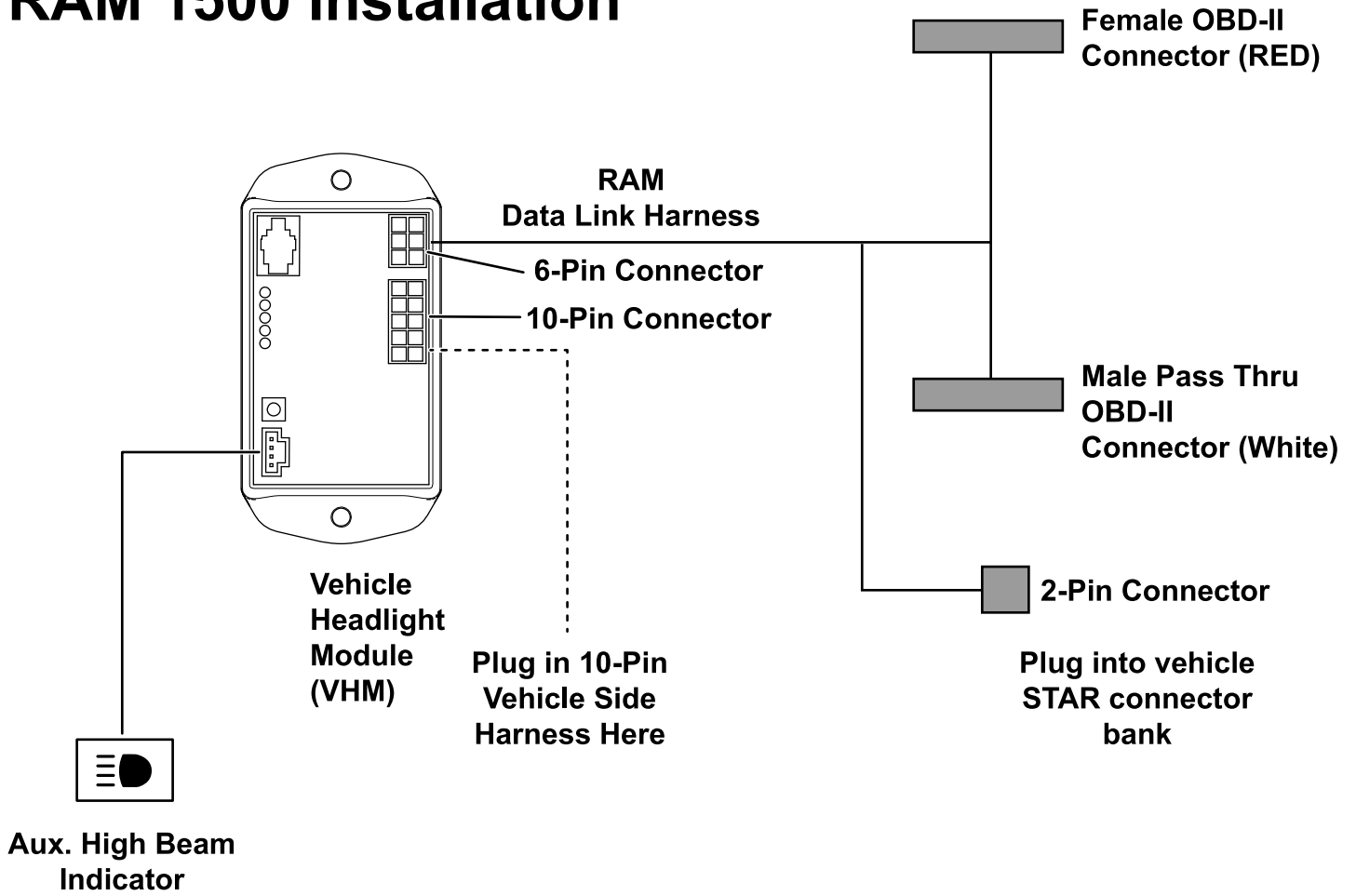

(Rev. 0)

g374298

Toyota Tundra Installation

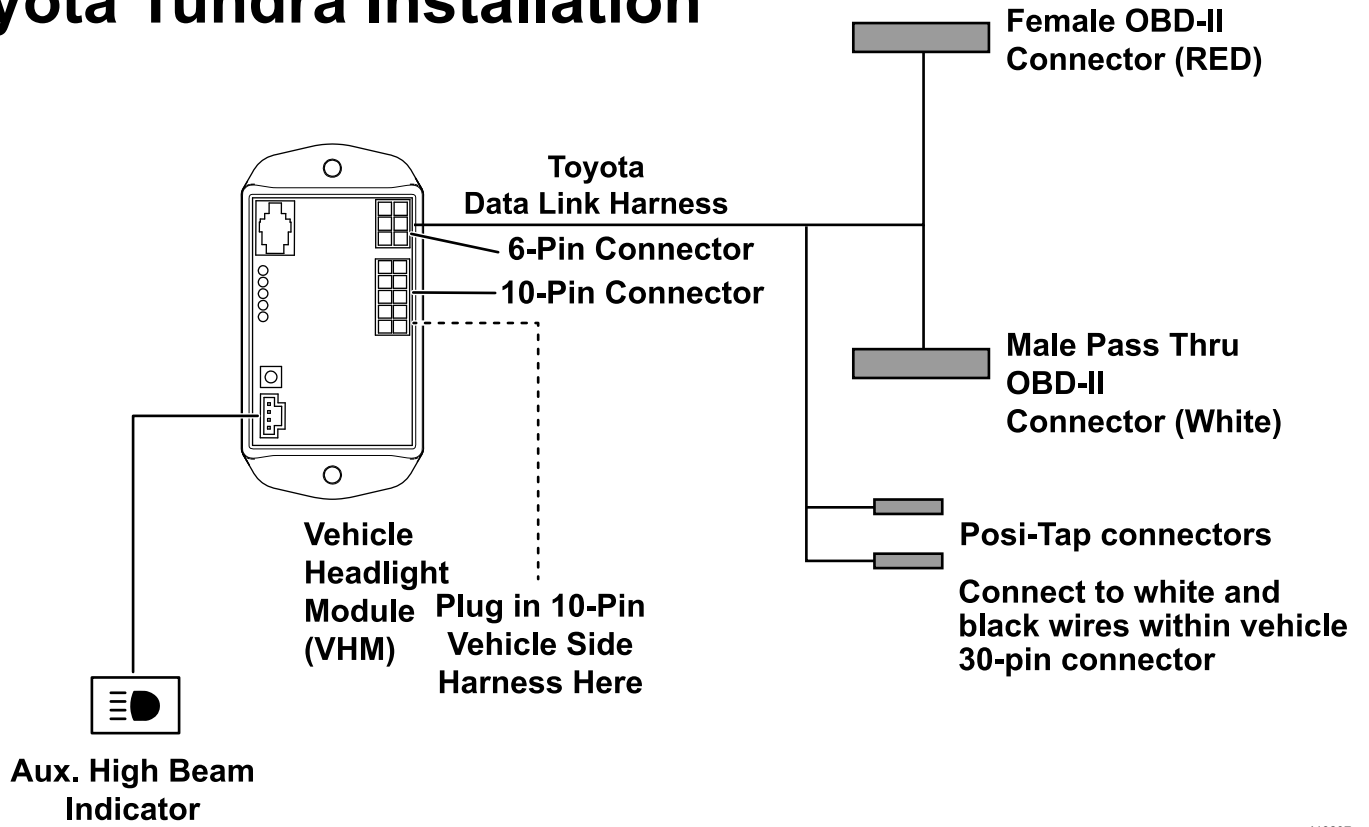

(Rev. 0)

g418297