



2010 The BOSS Way
Iron Mountain, MI 49801
United States

Installation Instructions

Plow Box

Straight Blade Tripedge

Part No. TRP25540—Serial No. 40000000 and Up

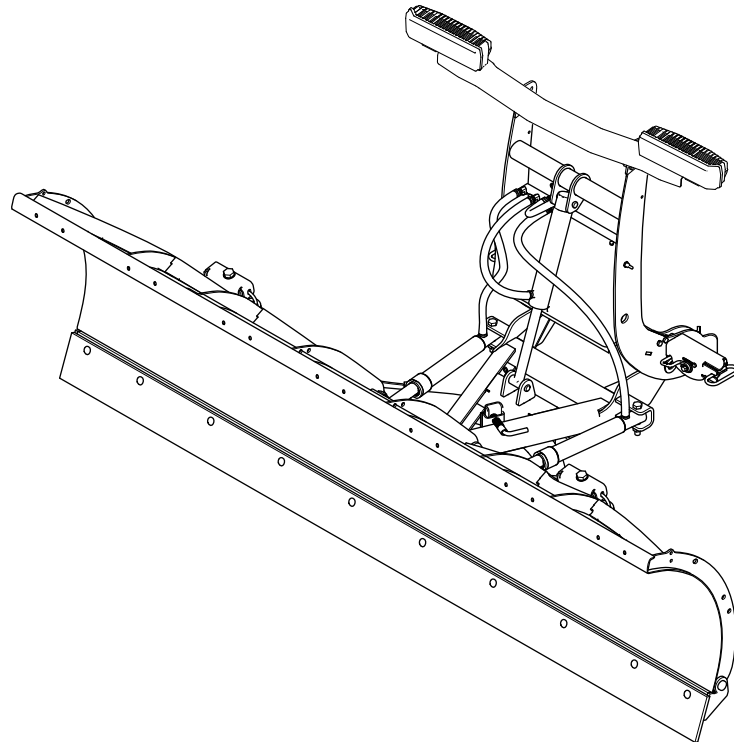

BOSS Products limited consumer warranty and BOSS Products commercial warranty policies are located at www.BOSSPlow.com.

Patent www.ttcopats.com.

Introduction

Note: This manual is used for the assembly of all BOSS trip-edge straight-blade plows. Illustrations may vary.

Read this information carefully to learn how to operate and maintain your product properly and to avoid injury and product damage. You are responsible for operating the product properly and safely.

Visit www.BOSSPlow.com for product safety and operation training materials, accessory information, help finding a dealer, or to register your product.

Whenever you need service, genuine BOSS parts, or additional information, contact an Authorized BOSS Dealer or BOSS Technical Service (1-800-286-4155) and have the model and serial numbers of your product ready. **Figure 1** identifies the location of the model and serial numbers on the product. Write the numbers in the space provided.

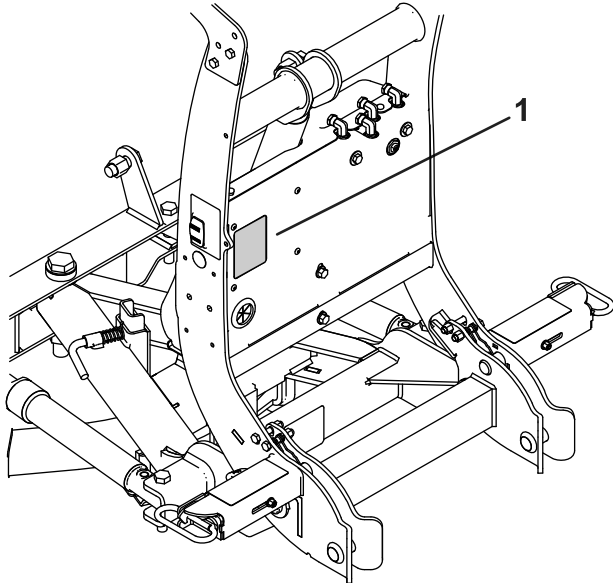

Figure 1

g535122

1. Model and serial number location

Date Purchased	_____
Model No.	_____
Serial No.	_____
Blade Crate Serial No.	_____

Safety-Alert Symbol

The safety-alert symbol (**Figure 2**) shown in this manual and on the machine identifies important safety messages that you must follow to prevent accidents.



g000502

Figure 2

Safety-alert symbol

The safety-alert symbol appears above information that alerts you to unsafe actions or situations and is followed by the word **DANGER**, **WARNING**, or **CAUTION**.

DANGER indicates an imminently hazardous situation which, if not avoided, **will** result in death or serious injury.

WARNING indicates a potentially hazardous situation which, if not avoided, **could** result in death or serious injury.

CAUTION indicates a potentially hazardous situation which, if not avoided, **may** result in minor or moderate injury.

This manual uses two other words to highlight information. **Important** calls attention to special mechanical information and **Note** emphasizes general information worthy of special attention.

Contents

Safety-Alert Symbol.....	2
Safety	3
Preparation.....	3
Operation.....	3
Safety and Instructional Decals	4
Installation	8
Installing the Plow Shoes.....	8
Installing the Push Frame and Coupler Tower	8
Installing the Hydraulic Hoses.....	10

Installing the Light Bar	10
Installing the Blade Guides and Filling the Hydraulic Reservoir.....	11
Mounting the Snowplow.....	12
Adjusting the Pushbeam Height.....	12
Aiming the Headlights.....	13
Product Overview	15
Controls	15
Specifications	17
Troubleshooting	18
Schematics	19

Safety

Improper use or maintenance by the operator or owner can result in injury. To reduce the potential for injury, comply with these safety instructions and always pay attention to the safety-alert symbol **A**, which means **Caution, Warning, or Danger**—personal safety instruction. Failure to comply with the instruction may result in personal injury or death.

Preparation

- Read the *Owner's Manual* before operating or servicing the plow.
- Always follow the vehicle manufacturer's recommendations relating to snowplow installation. For recommended vehicle models, refer to the BOSS product selector tool at www.BOSSPlow.com.
- Ensure that only trained personnel install and perform maintenance on the equipment and hydraulic components.
- Never disable, remove, or relocate any sensors or other components related to the operation of the air bags in your vehicle.
- Keep your hands, feet, and clothing away from moving parts and mounting points.
- Ensure the plow is properly attached to the vehicle before moving it.
- To comply with federal regulations and to assure a safe vehicle, do not exceed the front gross-axle-weight rating (FGAWR), rear gross-axle-weight rating (RGAWR), and the gross-vehicle-weight rating (GVWR) at any time.
- Always wear appropriate personal protective equipment when operating and servicing the machine. Wear substantial, slip-resistant footwear, and cold-weather clothing.
- Use a 500 kg (1/2 ton) minimum lifting device to move heavy plow components.
- Material safety data sheets (MSDS) are available at www.BOSSPlow.com.

Operation

- Vehicles equipped with air bags are designed so that the air bags activate in a frontal collision equivalent to hitting a solid barrier (such as a wall) at approximately 22 km/h (14 mph) or more, or a frontal perpendicular collision with a parked car or truck of similar size at approximately 45 km/h (28 mph) or more. Careless or high-speed driving while plowing snow can deploy the air bag.

- When transporting the vehicle, position the plow so as not to block your vision or the plow headlights.
- Do not change the blade position when traveling.
- Do not exceed 64 km/h (40 mph) when transporting the plow.
- Do not exceed 22 km/h (14 mph) when plowing.
- Do not exceed 8 km/h (5 mph) when D-Force is activated (if equipped).
- Always lower the blade when the vehicle is not in use.
- Never put any part of your body between the plow and the vehicle.
- Do not operate the machine while ill, tired, or under the influence of alcohol or drugs.
- Use your full attention while operating the machine. Do not engage in any activity that

causes distractions; otherwise, injury or property damage may occur.

- Always wear your seat belt while operating a motor vehicle.
- Due to the variety of equipment that you can install on the vehicle, do not exceed the front gross-axle-weight rating (FGAWR), rear gross-axle-weight rating (RGAWR), and the gross-vehicle-weight rating (GVWR) at any time. This may require weighing the vehicle and adding ballast as necessary. It may also limit the payload capacity of the vehicle.
- This machine has an operating sound level below 70 dBA.
- When transporting the machine, ensure that it is properly secured. Instructions are available at www.BOSSPlow.com.

Safety and Instructional Decals



Safety decals and instructions are easily visible to the operator and are located near any area of potential danger. Replace any decal that is damaged or missing.

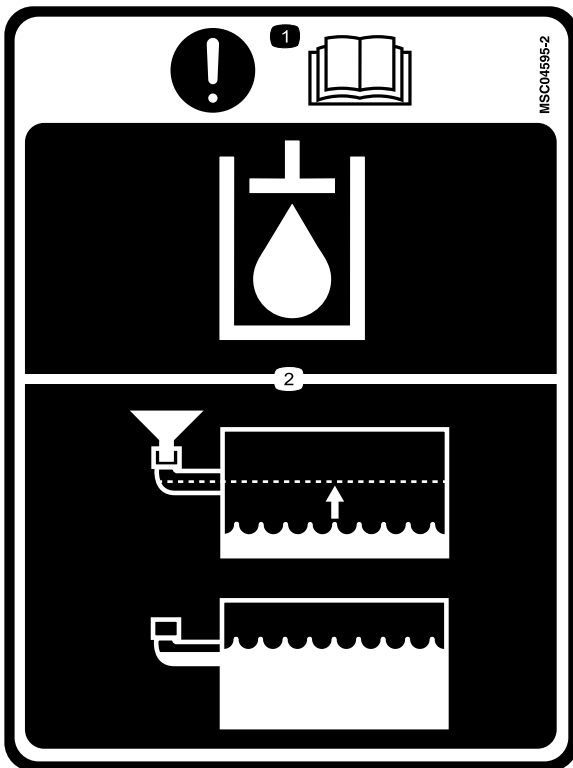

MSC04595

decalsmc04595

1. Important—read the *Owner's Manual*.
2. Fill the hydraulic fluid to the bottom of the fill elbow.

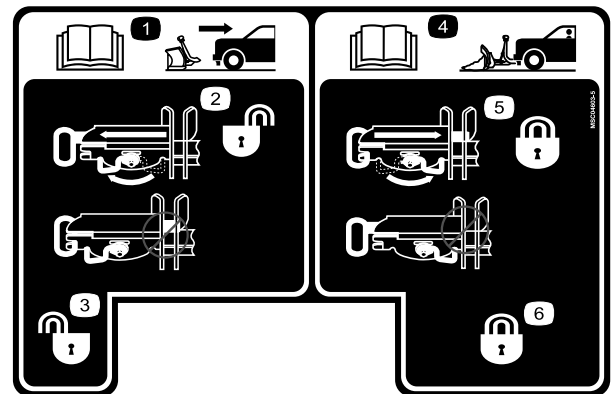

decalsmc04603-5

MSC04603-5

1. Read the *Owner's Manual* for information on removing the plow.
2. Rotate the release lever clockwise and pull out the spring pin handle to unlock the coupler; do not leave the spring pin pushed in.
3. Coupler spring pin unlock
4. Read the *Owner's Manual* for information on attaching the plow.
5. Rotate the release lever counterclockwise and push in the spring pin handle to lock the coupler; do not leave the spring pin pulled out.
6. Coupler spring pin lock

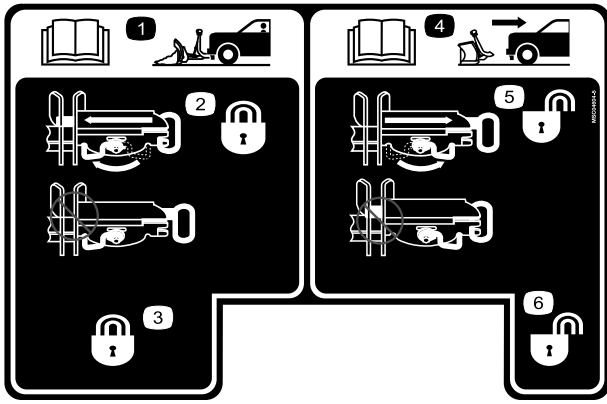

decalmsc04604-5

MSC04604-5

- | | |
|--|---|
| 1. Read the <i>Owner's Manual</i> for information on attaching the plow. | 4. Read the <i>Owner's Manual</i> for information on removing the plow. |
| 2. Rotate the release lever clockwise and push in the spring pin handle to lock the coupler; do not leave the spring pin pulled out. | 5. Rotate the release lever counterclockwise and pull out the spring pin handle to unlock the coupler; do not leave the spring pin pushed in. |
| 3. Coupler spring pin lock | 6. Coupler spring pin unlock |

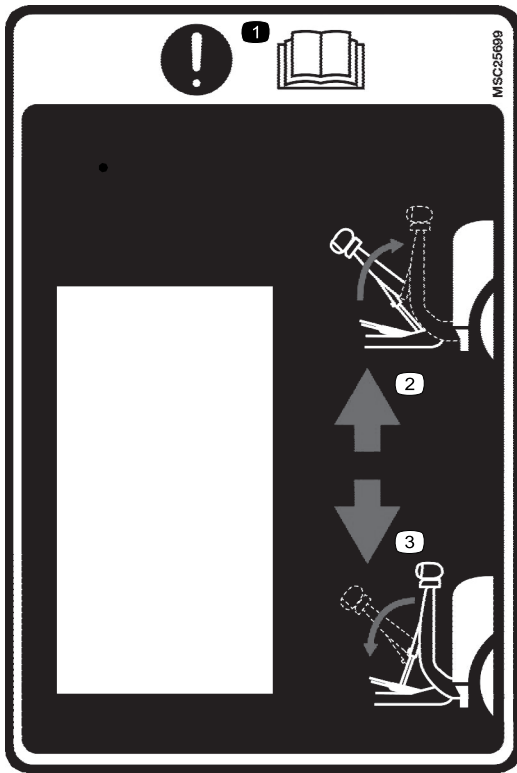

decalmsc25699

MSC25699

- | | |
|---|-----------------------------|
| 1. Important—read the <i>Owner's Manual</i> . | 3. Lower the coupler tower. |
| 2. Raise the coupler tower. | |

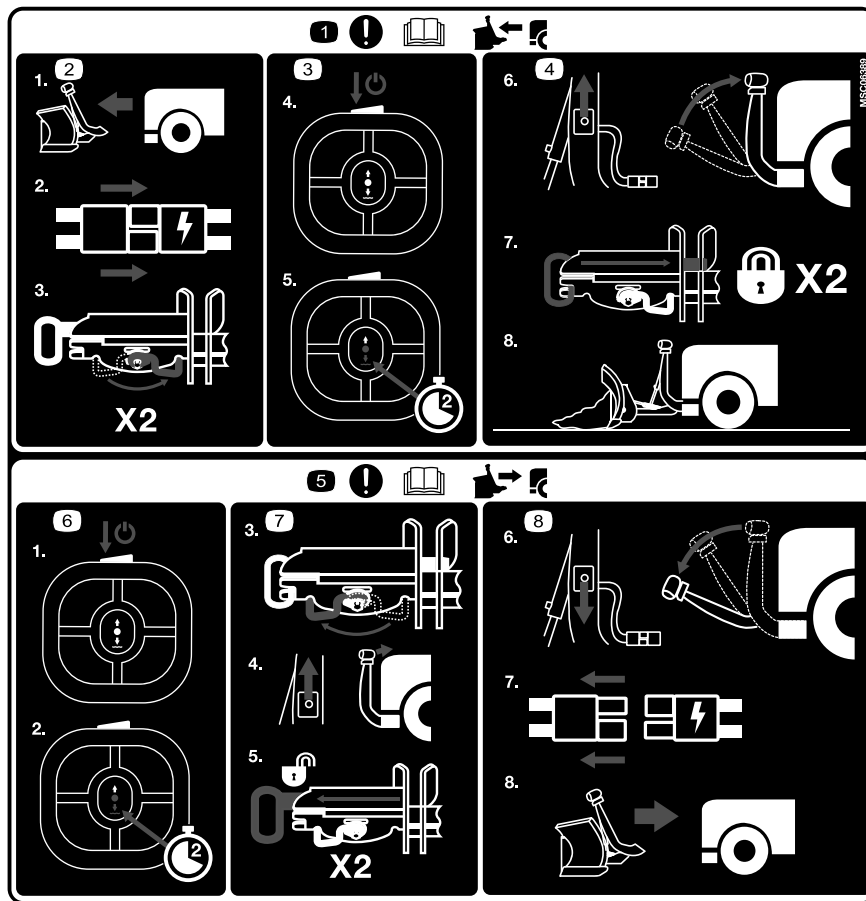

MSC06389

decalmsc06389

1. Attention—read the *Owner's Manual* before attaching the plow.
2. Slowly align the vehicle with the plow, connect the electrical plugs, and turn the coupler levers to the LOCK position.
3. Turn on the SmartTouch+ controller, and press down for 2 seconds to activate FLOAT mode.
4. Push the SmartHitch2 switch on the side of the coupler tower upward to raise the tower, ensure that both of the coupler spring pins are engaged, and the plow is ready for operation.
5. Attention—read the *Owner's Manual* before removing the plow.
6. Turn on the SmartTouch+ controller, and press down for 2 seconds to activate FLOAT mode.
7. Turn the levers on the coupler to the UNLOCK position, push the SmartHitch2 switch on the side of the coupler tower upward to raise the tower, and ensure that both of the coupler spring pins are disengaged.
8. Push the SmartHitch2 switch on the side of the coupler tower downward to disconnect the plow, disconnect the electrical plugs, and slowly back away from the plow.

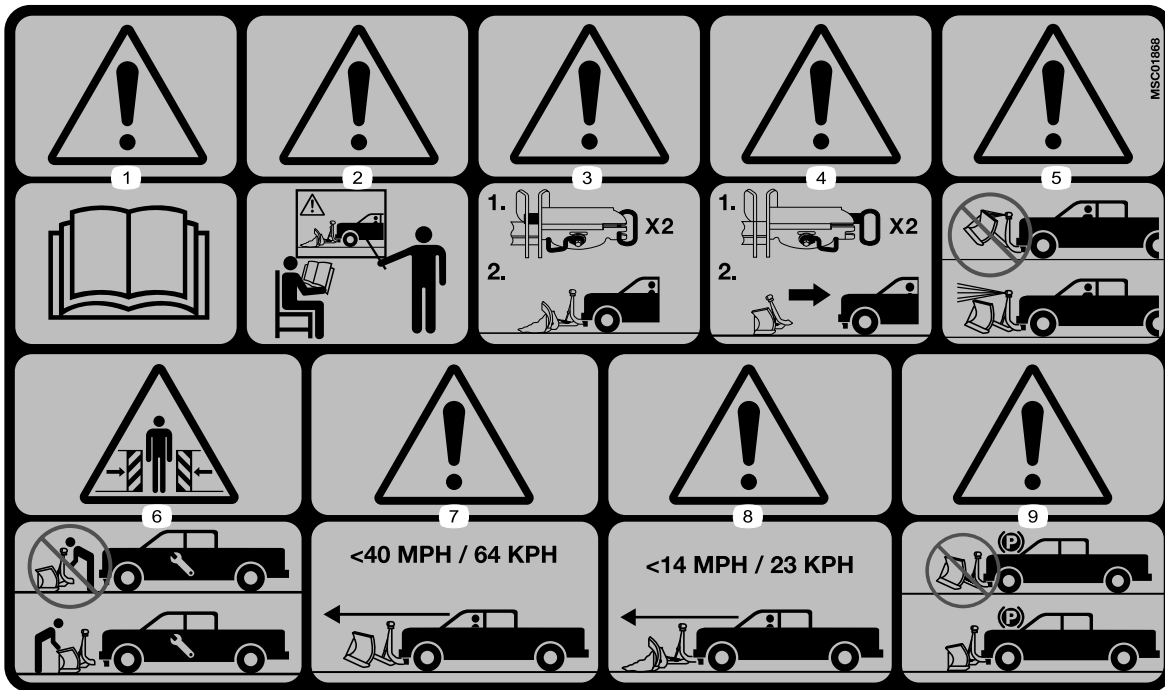

decalmsc01868

MSC01868

1. Warning—read the *Owner's Manual*.
2. Warning—all operators should be trained before operating the machine.
3. Warning—coupler spring pins must be locked before plowing.
4. Warning—coupler spring pins must be unlocked to remove the plow.
5. Warning—do not block the vehicle headlights with the plow.
6. Crushing hazard—do not stand between the plow and vehicle during maintenance.
7. Warning—do not exceed 64 km/h (40 mph) when transporting the plow.
8. Warning—do not exceed 22 km/h (14 mph) when plowing.
9. Warning—lower the plow when the vehicle is not in use.

Installation

Determine the left and right sides of the machine from the normal operating position.

Installing the Plow Shoes

1. Slide a washer onto each of the plow shoes (Figure 3).

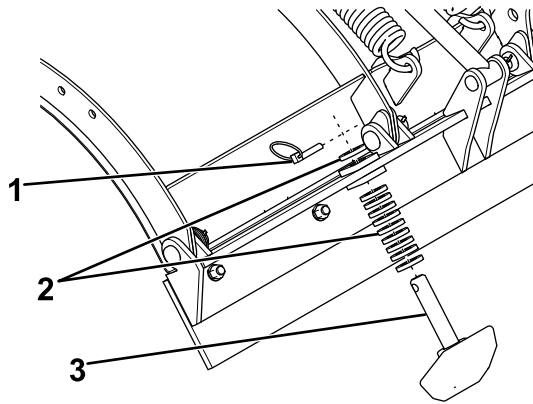

Figure 3

g272364

1. Quick pin
2. Washers
3. Plow shoe

2. Slide the plow shoes into the holes on the bottom of plow (Figure 3).
3. Slide another washer onto the plow shoes and secure them with a quick pin (Figure 3).

Note: Adjust the number of washers above and below the mounting point until the shoe is flush with the bottom of the plow blade.

Installing the Push Frame and Coupler Tower

1. Secure the pushframe attachment bar to the plow using 10 bolts (3/4 inch) and locknuts (Figure 4).

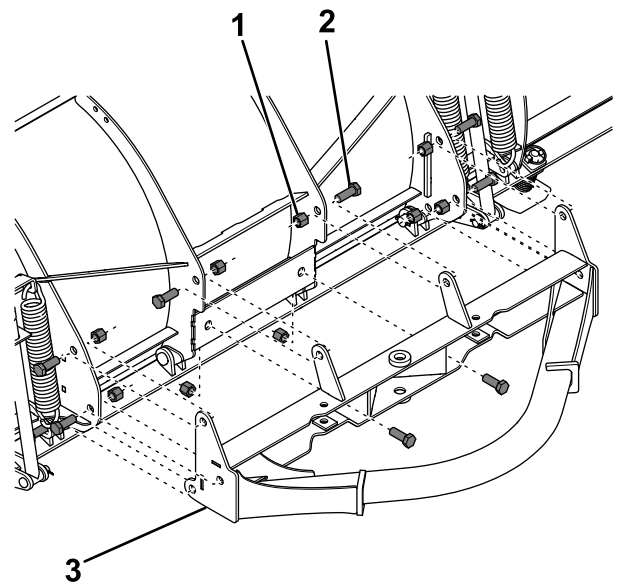

Figure 4

g272365

1. Locknut (3/4 inch)
2. Bolt (3/4 inch)
3. Pushframe attachment bar

2. Torque the bolts to 272 N·m (201 ft-lb).
3. Attach the pushframe to the pushframe attachment bar using a bolt (1 inch) and locknut (Figure 5).

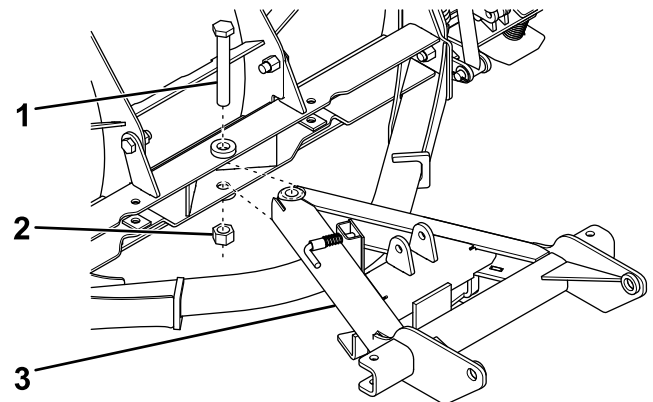

Figure 5

g272366

1. Bolt (1 inch)
2. Locknut (1 inch)
3. Pushframe

4. Pull the kickstand spring pin and insert the kickstand into the mounting bracket, then release the spring pin to lock the kickstand in place in the lowered position (Figure 6).

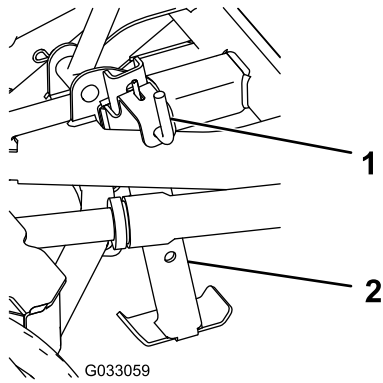

Figure 6

1. Kickstand spring pin 2. Kickstand

5. Secure the hydraulic angle cylinders to the plow using 2 bolts (5/8 inch) and locknuts (Figure 7).

Note: Ensure that the port on the hydraulic cylinder is pointed upwards.

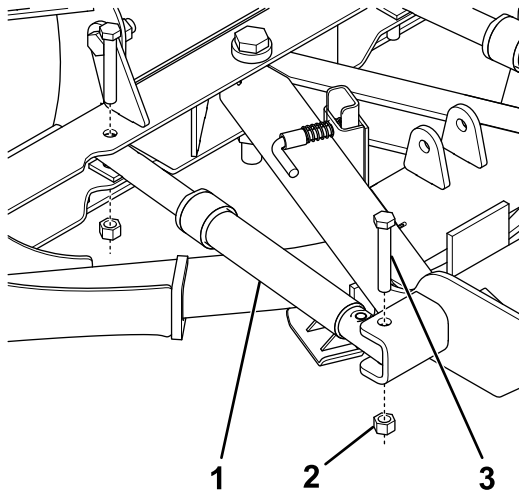

Figure 7

1. Hydraulic angle cylinder 3. Bolt (5/8 inch)
2. Locknut (5/8 inch)

6. Align the pivot holes of the coupler tower with the pivot holes on the push-frame assembly, and secure them with a clevis pin (1 inch), flat washer (1 inch), bolt (3/8 x 1-1/2 inches), washer (3/8 inch), and locknut (Figure 8).

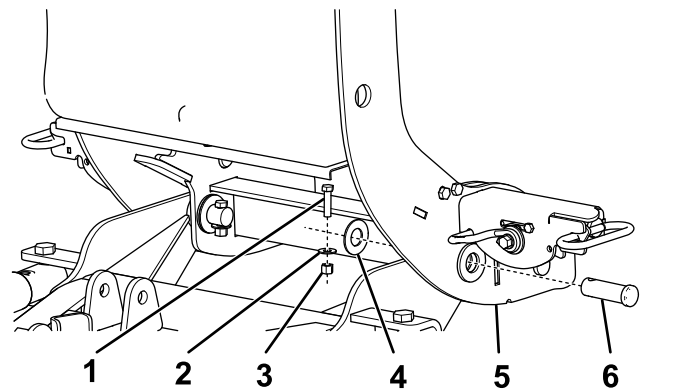

Figure 8

1. Bolt (3/8 x 1-1/2 inches) 4. Flat washer (1 inch)
2. Washer (3/8 inch) 5. Coupler tower
3. Locknut (3/8 inch) 6. Clevis pin (1 inch)

7. Secure the rod end of the lift cylinder to the push-frame assembly using a clevis pin (5/8 inch) and hairpin cotter (Figure 9).

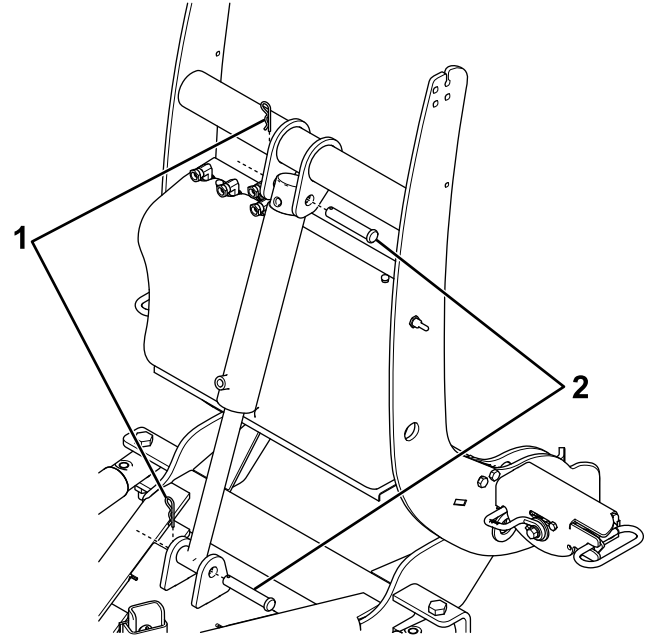

Figure 9

1. Hairpin cotter 2. Clevis pin (5/8 inch)

8. Secure the free end of the lift cylinder to the coupler tower using a clevis pin (5/8 inch) and hairpin cotter (Figure 9).

Installing the Hydraulic Hoses

1. Install a swivel fitting to the lower port on the lift cylinder (Figure 10).
2. Install the 45 cm (18 inch) hydraulic hose to the middle fitting on the hydraulic shelf and the lower fitting on the lift cylinder (Figure 10). Turn the fitting until it is finger tight, then turn it 2 to 3 more times.

Important: Do not overtighten.

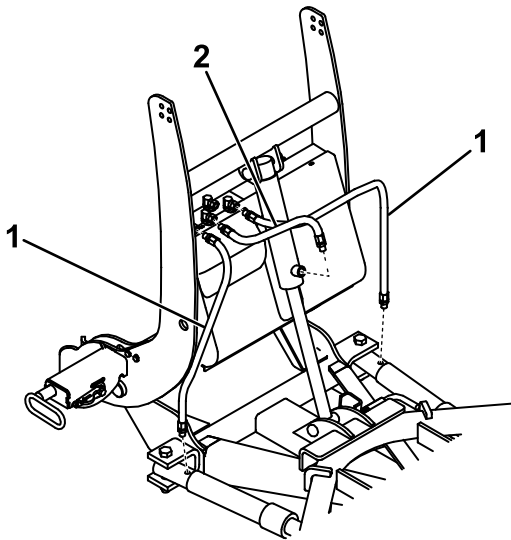

Figure 10

1. 45 cm (18 inch) hose
2. 106 cm (42 inch) hoses

3. Apply thread-locking compound to the threads on the O-ring end of the 106 cm (42 inch) hydraulic hoses.

Important: Do not get thread-locking compound on the end of the hose as it will contaminate the hydraulic system.

4. Install the O-ring end of the 106 cm (42 inch) hydraulic hose to the port on the right angle cylinder and the other end to the right fitting on the hydraulic shelf (Figure 10). Turn the fitting until it is finger tight, then turn it 2 to 3 more times.

Important: Do not overtighten.

5. Repeat step 4 on the left side.
6. Remove the plug on the upper fitting on the lift cylinder (Figure 11).

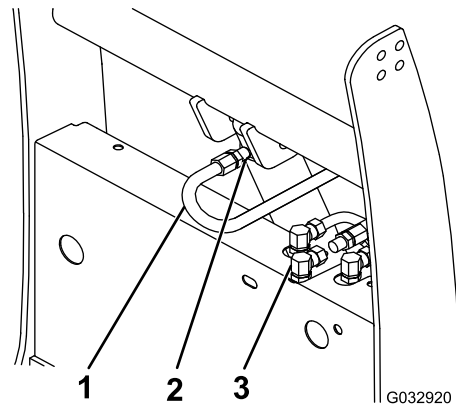

Figure 11

1. 39 cm (15-1/2 inch) hose
2. Upper lift-cylinder fitting
3. Rear fitting

7. Apply thread-locking compound to the threads on 1 end of the 39 cm (15-1/2 inch) hydraulic hose.
8. Install that end of the hose to the upper fitting on the lift cylinder (Figure 11). Turn the fitting until it is finger tight, then turn it 2 to 3 more times.

Important: Do not overtighten.

9. Creating an “S” shape with the hose, connect the free end of the hydraulic hose to the rear fitting on the hydraulic shelf (Figure 11). Turn the fitting until it is finger tight, then turn it 2 to 3 more times.

Important: Do not overtighten.

Installing the Light Bar

1. Secure the light bar to the top of the coupler tower through the rear holes using 4 bolts (3/8 x 1-1/4 inches) and self-locking nuts (3/8 inch). Torque the bolts to 31 N·m (23 ft-lb).

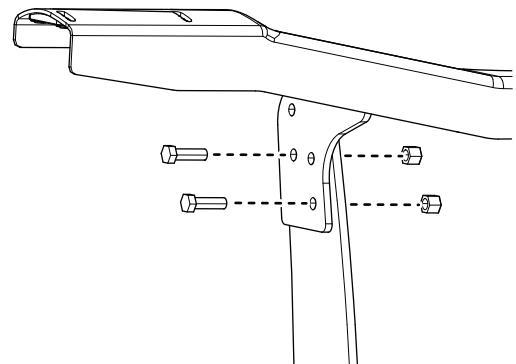

Figure 12

2. Install the headlights using the mount clamps, flat washers, split washers, and nuts shown in the figure below. Tighten the nuts finger tight.

Important: Do not use thread-locking compound on these bolts.

Note: Do not tighten the fasteners at this time.

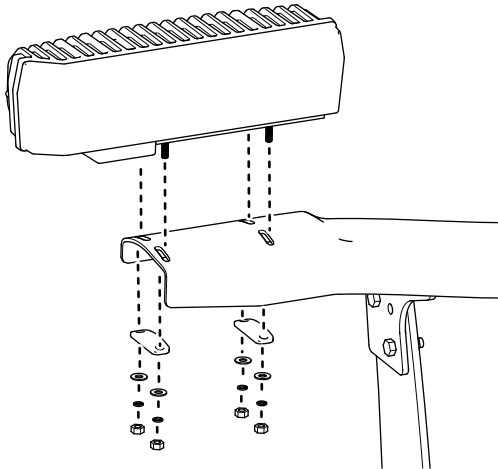

Figure 13

g511768

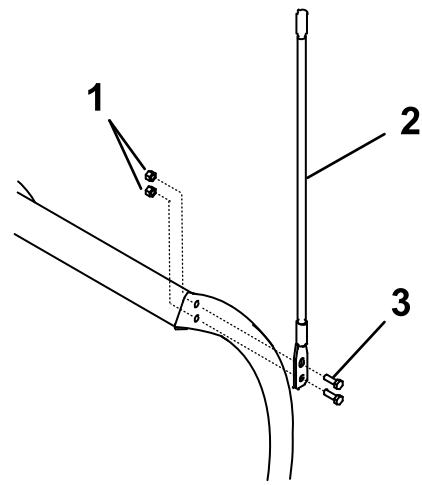

Figure 15

g212717

1. Self-locking nut
2. Blade guide
3. Bolt (5/16 x 1 inch)

3. Insert the headlight connectors on the wire harness to the back of the headlight housing. The short length connects to the left headlight and the long length connects to the right headlight.

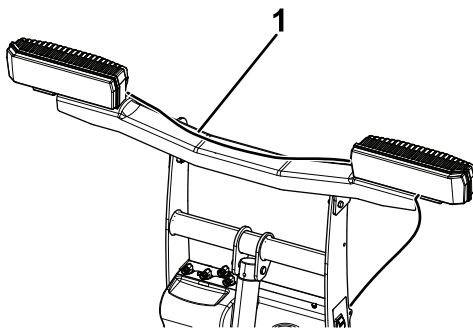

Figure 14

g511975

1. Short wire harness

4. Secure the wire harness to the light bar using 3 cable ties.

Installing the Blade Guides and Filling the Hydraulic Reservoir

1. Attach the blade guides to the plow blade using 4 bolts (5/16 x 1 inch) and 4 self-locking nuts (Figure 15).

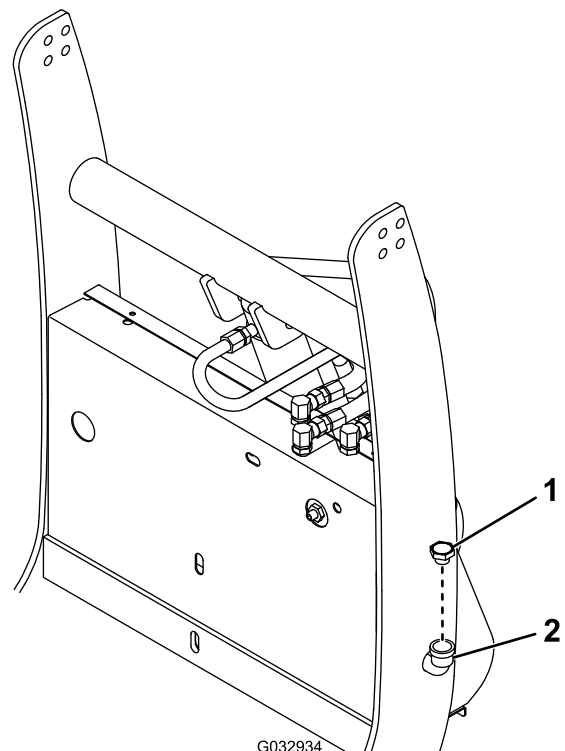

Figure 16

g032934

1. Fill cap
2. Hydraulic reservoir

4. Slowly fill the reservoir with BOSS high-performance hydraulic fluid until it accepts no more.

Note: The reservoir holds approximately 1.9 L (2 US qt) of hydraulic fluid.

5. Install the previously removed fill cap.

Mounting the Snowplow

Note: The vehicle must be running before starting this procedure.

1. Activate the FLOAT feature on your plow controller.
2. Line up the vehicle with the snowplow and slowly drive forward until the lower pin contacts the push-beam pin receiver (Figure 17).

Note: Ensure that the pushbeam is at the correct height for your plow. Refer to [Specifications \(page 17\)](#) for the recommended pushbeam height. Refer to [Adjusting the Pushbeam Height \(page 12\)](#) if the pushbeam is not at the correct height.

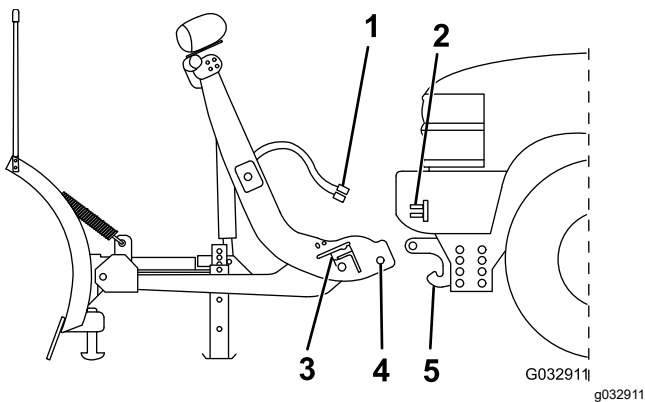

Figure 17

- | | |
|-------------------------|-----------------|
| 1. Plow wire harness | 4. Lower pin |
| 2. Vehicle wire harness | 5. Pin receiver |
| 3. Coupler | |

3. Turn the levers on the couplers to the ON position (Figure 18).

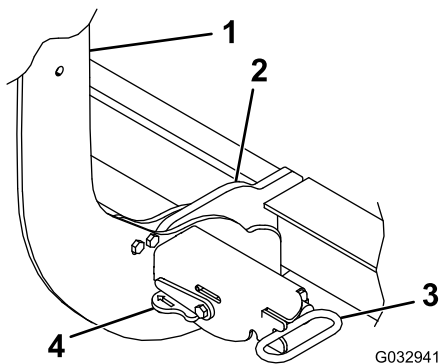

Figure 18

- | | |
|------------------|-----------------------|
| 1. Coupler tower | 3. Coupler spring-pin |
| 2. Pin receiver | 4. Coupler lever |

4. Remove the electrical-plug dust-covers and connect the plow wire harness to the vehicle wire harness (Figure 17).
5. Push the SmartHitch2 switch on the side of the coupler tower upward and raise the tower until the coupler spring pins snap in (Figure 19).

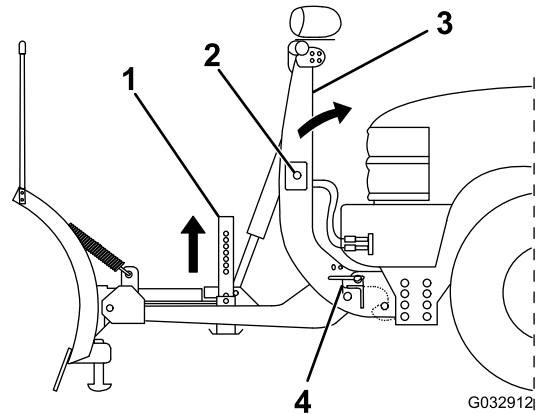

Figure 19

- | | |
|-----------------------|-----------------------|
| 1. Kickstand | 3. Coupler tower |
| 2. SmartHitch2 switch | 4. Coupler spring pin |

6. Ensure that both coupler spring pins have fully engaged the coupler (Figure 18).

Note: Move the coupler tower until the spring pins engage completely.

7. Pull the kickstand spring pin outward and raise the kickstand, then release the spring pin to secure it (Figure 19).
8. Switch the vehicle headlight switch to the PARK position.

Adjusting the Pushbeam Height

Optional

1. Measure the distance from the ground to the coupler spring-pin holes on the undercarriage pushbeam (Figure 20). The measurement should match the height listed for your plow in [Specifications \(page 17\)](#).
2. If the pushbeam is not at the correct height, remove the fasteners securing the pushbeam to the undercarriage (Figure 20).
3. Move the pushbeam up or down and secure it with the previously removed hardware.
4. Torque the fasteners to 76 N·m (56 ft-lb).

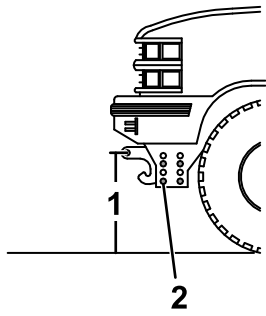

Figure 20

g230889

1. Measure this distance.
2. Fastener

Aiming the Headlights

Important: Certify that the installation of the snowplow lights conforms to applicable federal motor vehicle safety standards.

1. Park the vehicle on a level surface 7.5 m (25 ft) away from a matte white screen or garage door.

Note: The screen should be perpendicular to both the ground and the front of the vehicle.

2. Ensure that the vehicle is equipped for normal operation with the snowplow attached and in the raised position.
3. Perform the following actions to ensure optimal headlight alignment:
 - Remove any ice or mud from under the fenders.
 - Ensure that all tires are fully and evenly inflated.
 - Check vehicle springs for sag or broken leaves.
 - Check the function of any level ride controls.
 - Stabilize the suspension by rocking the vehicle sideways.
 - Ensure that there is no load in the vehicle other than the driver.
 - Clean the headlights and matte white screen.

4. Measure the distance between the ground and the center of the headlight. The center is indicated by a dot on the interior black housing.

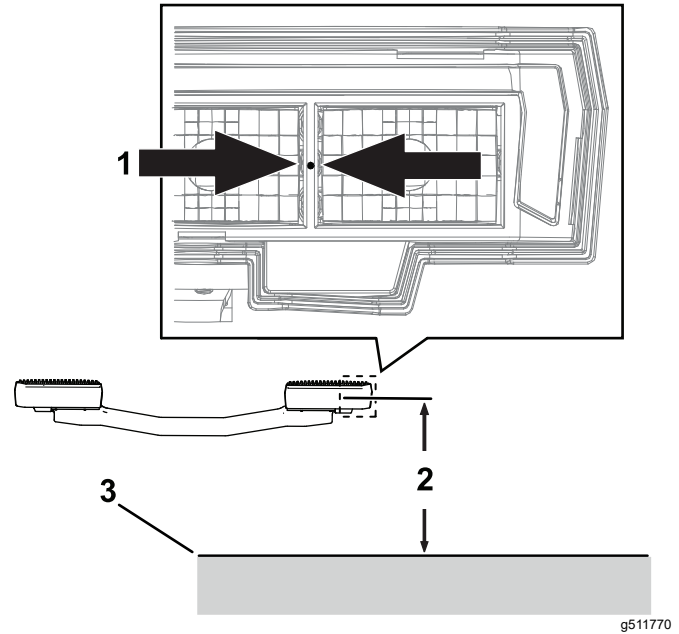

Figure 21

g511770

1. Center dot location
2. Measurement
3. Ground

5. Using the measurement from the previous step, mark a horizontal line starting from the ground on the screen.
6. With one headlight covered and only the low beam on, adjust the position of the light on the screen by pivoting the headlight front to back.

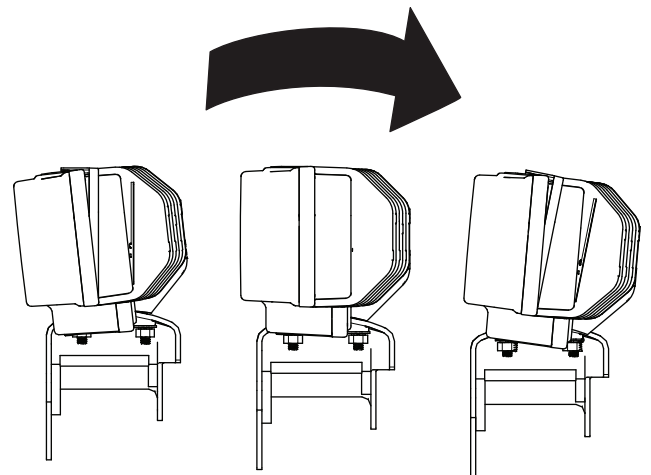

Figure 22

g511822

7. The headlight is in the correct position when the transition from the brightest portion of the light to the upper dark region is centered on the horizontal line as shown.

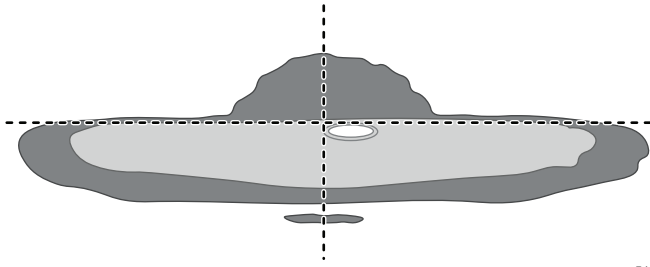

Figure 23

g511833

-
8. Torque the headlight to 8.1 N·m (6 ft-lb)
 9. Repeat steps 6 through 8 on the other headlight.
 10. The final illumination pattern on the screen should be a continuous horizontal line with no significant difference between the left and right light patterns.

Product Overview

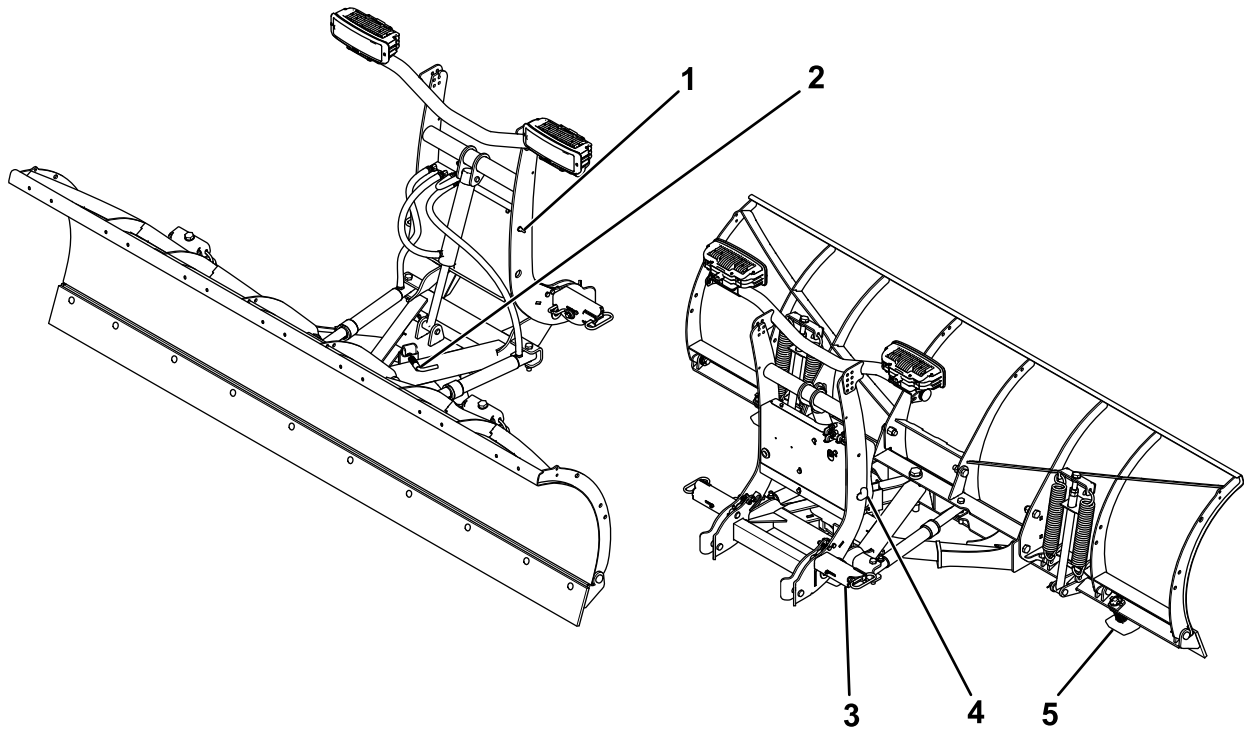

Figure 24

g272371

- 1. SmartHitch2 switch
- 2. Kickstand
- 3. Spring pin

- 4. Hydraulic fluid fill elbow
- 5. Plow shoe

Controls

SmartHitch2 Switch

The SmartHitch2 switch controls the movement of the coupler tower to facilitate plow attachment and removal. With the controller in the Float mode, press the switch up to raise the tower and down to lower the tower.

Spring Pins

The spring pins secure the plow to the vehicle pushbeam. Turn the levers toward the coupler tower to lock the spring pins. Turn the levers away from the coupler tower to unlock the spring pins.

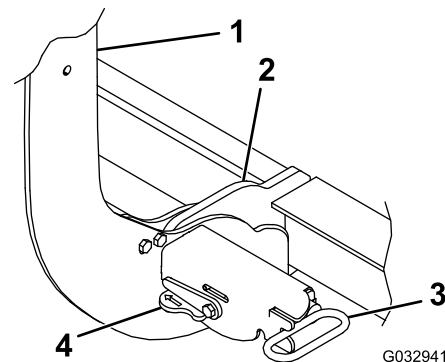

Figure 25

G032941

g032941

- 1. Coupler tower
- 2. Pin receiver
- 3. Spring pin
- 4. Lever

Truck Headlight Switch

The SmartLight 4 (SL4) plow headlights will remain on whenever the vehicles key switch is on. Federal law requires the vehicle headlights are disabled (off) when auxiliary plow lights are enabled (on). Ensure the vehicles headlight switch is set to PARK mode whenever plow lights are enabled.

SmartTouch+ Controller

The SmartTouch+ controller operates the movement of the snowplow.

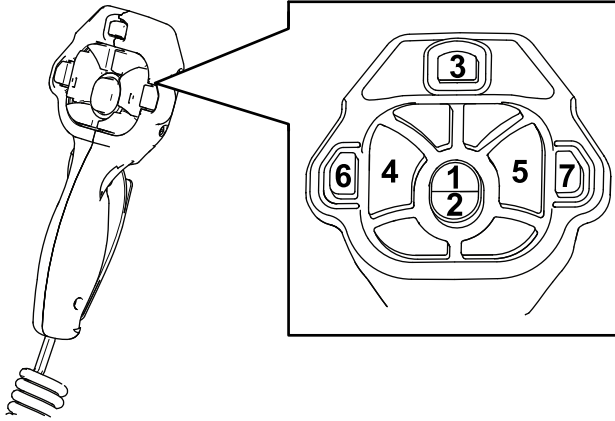
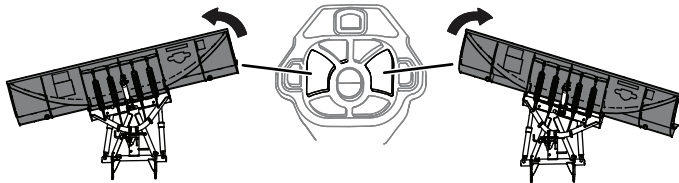

Figure 26

g506711

- | | |
|----------------------|-----------------------|
| 1. Raise button | 5. Right angle button |
| 2. Lower button | 6. AUX 1 button |
| 3. On/Off switch | 7. AUX 2 button |
| 4. Left angle button | |



g513995

Figure 27

Straight-blade plow articulations

- On/Off switch—turns the plow controller on and off. The controller illuminates solid green when the controller is on.

Note: Turn off the controller when not in use to prevent accidental activation of the plow.
- Raise button—raises the plow blade. Quickly pressing the raise button twice automatically raises the blade when express raise mode is enabled. To enable or disable express raise, refer to the product *Owner's Manual*.
- Lower button—lowers the plow blade and activates the FLOAT and D-FORCE features.
 - FLOAT—double tapping the button or holding it for 2 seconds automatically lowers the blade and activates the FLOAT feature, allowing the plow blade to follow the contour of the ground. A red light illuminates when the FLOAT feature is active.
 - D-FORCE (optional)—if your plow is equipped with the D-FORCE feature, double tapping the button a second time activates it, applying a downward force on the blade to improve back blading. An orange light illuminates when the D-FORCE feature is active.

Important: Only use the D-Force feature while back dragging to prevent damage to the plow or vehicle.

- Left button—angles the plow blade to the left
- Right button—angles the plow blade to the right
- AUX 1 and AUX 2 buttons—can be programmed to perform various functions; refer to the product *Owner's Manual*.
- Sleep mode—If you do not use the controller for 20 minutes, it enters sleep mode and the controller lights flash green and red. Turn the controller off to deactivate the sleep mode.

Kickstand

Pull the kickstand spring pin to raise and lower the kickstand.

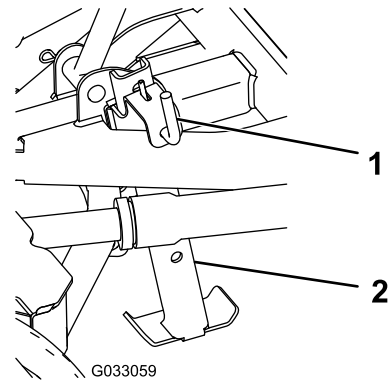

G033059

Figure 28

g033059

- | | |
|-------------------------|--------------|
| 1. Kickstand spring pin | 2. Kickstand |
|-------------------------|--------------|

Plow Shoes

Plow shoes control how much contact the cutting edge of the plow has with the surface being plowed. When plowing solid, level areas, such as parking lots, roads, or driveways, plow shoes should be raised to increase contact. When plowing loose or uneven surfaces, such as dirt, gravel, or grass, plow shoes should be lowered to decrease contact and prevent the surface from being dug up.

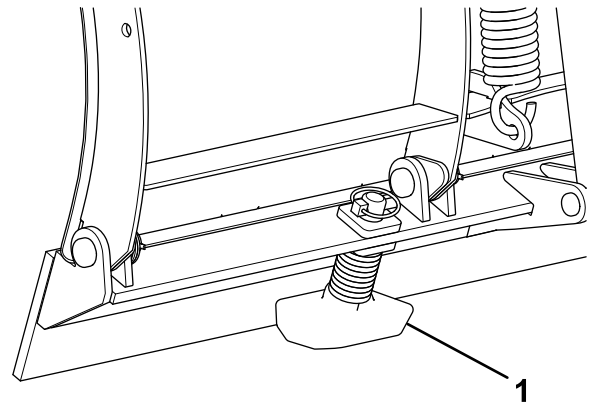

Figure 29

g272370

1. Plow shoe

Specifications

Blade width	Material	Blade height	Weight	Recommended pushbeam height
2.29 m (90 inches)	Steel	79 cm (31 inches)	350 kg (772 lb)	39.3 cm (15-1/2 inches)
2.44 m (96 inches)	Stainless steel		385 kg (849 lb)	
	Steel		357 kg (788 lb)	
2.74 m (108 inches)	Stainless steel		407 kg (897 lb)	
	Steel		376 kg (828 lb)	

Troubleshooting

Problem	Possible Cause	Corrective Action
Fluid leaks from the lift cylinders.	<ol style="list-style-type: none"> 1. The fittings are loose or the O-rings are damaged. 	<ol style="list-style-type: none"> 1. Tighten loose fittings.
The SmartHitch2 does not attach to the plow.	<ol style="list-style-type: none"> 1. The controller is not in the FLOAT position. 2. The controller is malfunctioning. 3. The valve block and SmartHitch2 switch are not properly connected. 	<ol style="list-style-type: none"> 1. Turn the vehicle on and put the controller in the FLOAT position. 2. Replace the controller. 3. Check valve block and the SmartHitch2 switch for proper connections; refer to the manifold wiring diagram included with your <i>Owner's Manual</i>.
The blade digs into the ground in the V position.	<ol style="list-style-type: none"> 1. The bumper stop is not in the correct position. 2. The pushbeam is installed too high. 	<ol style="list-style-type: none"> 1. Adjust the bumper-stop position. 2. Lower the pushbeam.
The blade does not lay flat on the ground in the scoop position.	<ol style="list-style-type: none"> 1. The bumper stop is not in the correct position. 2. The pushbeam is installed too low. 	<ol style="list-style-type: none"> 1. Adjust the bumper-stop position. 2. Raise the pushbeam. If the pushbeam is at the highest setting, adjust the bumper stop further into the center section.

Schematics

BOSS SNOWPLOW | RT3 STRAIGHT BLADE WITH SMARTHITCH2™

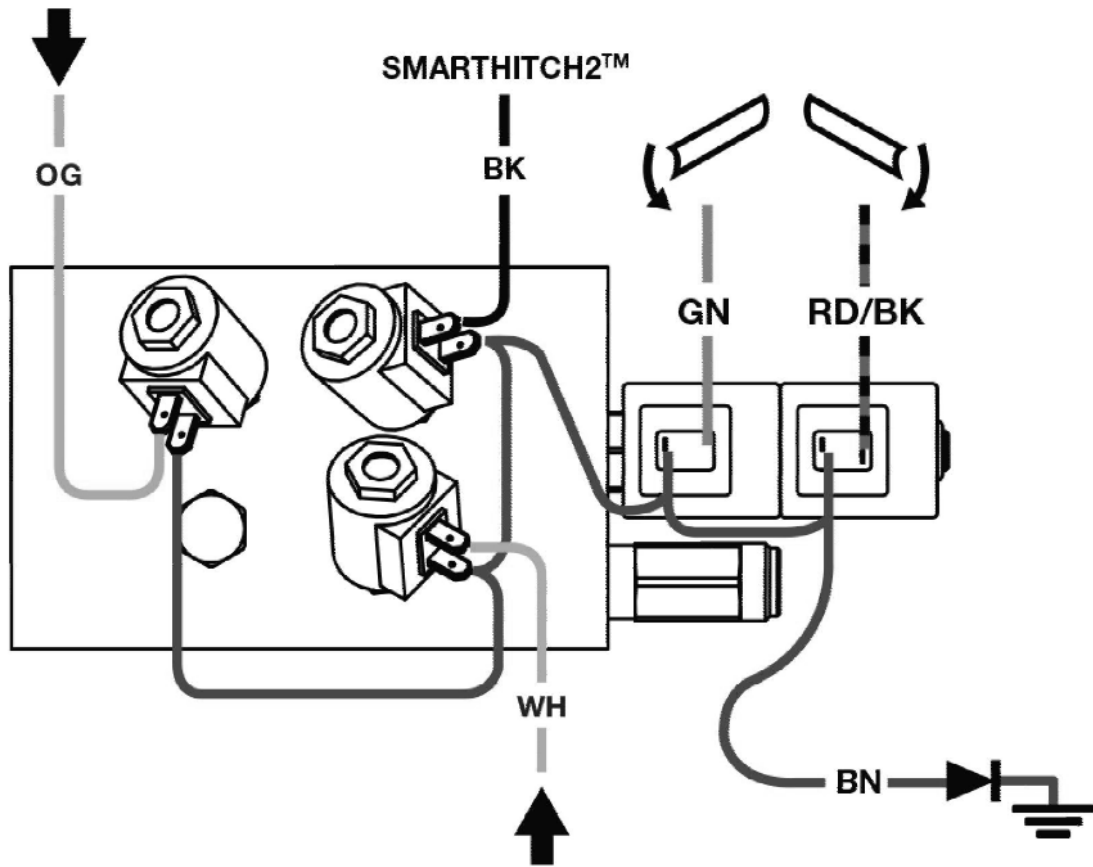

g535145

Wire Color	Function
Green	Blade left
Red	Blade right
White	Lift
Orange	Lower
Red/Black	Blade right
Blue	Blade left
Black	SmartHitch2
Brown	Ground

RT3 Straight Blade (Rev. 0)

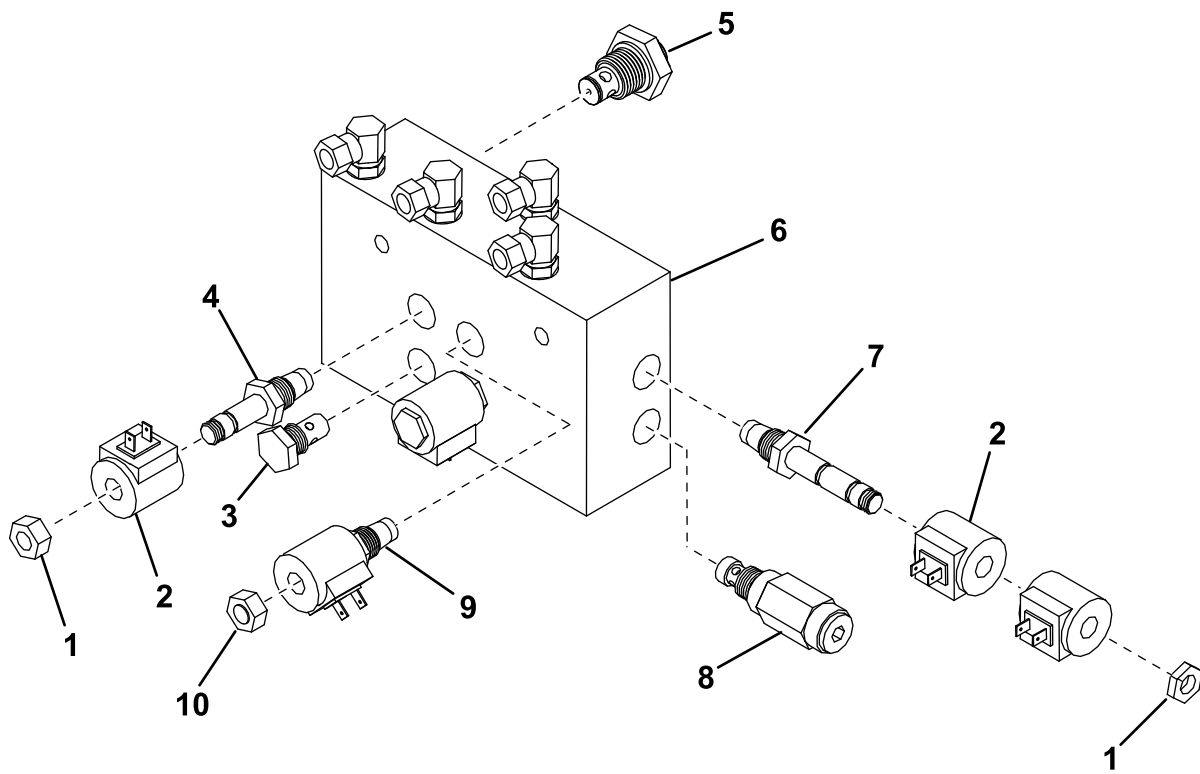

g212234

Ref.	Part Number	Qty.	Description
1	HYD07059	2	Nut, Coil — used with valve HYD01637 & HYD07100
2	HYD01638	5	Coil, Hydraulic Valve
3	HYD01640	1	Check Valve
4	HYD01637	2	Hydraulic Valve, Lift/Lower Cartridge
5	HYD07048	1	Hydraulic Valve, Flow Control Cartridge
6	HYD07122	1	Hydraulic Valve Assembly with SmartHitch2 (Red)
7	HYD07100	1	Hydraulic Valve, Angle Cartridge (3 Position - 4 Way Spool)
8	HYD07027	1	Relief Valve, Hydraulic Crossover (3,800 PSI)
9	HYD07047	1	Hydraulic Valve, SmartHitch2 Attach
10	HYD07060	1	Nut, Coil - used with valve HYD07047

Hydraulic Manifold Parts List (Rev. 0)

Notes:

Notes:

Notes:

BOSS
S N O W P L O W