

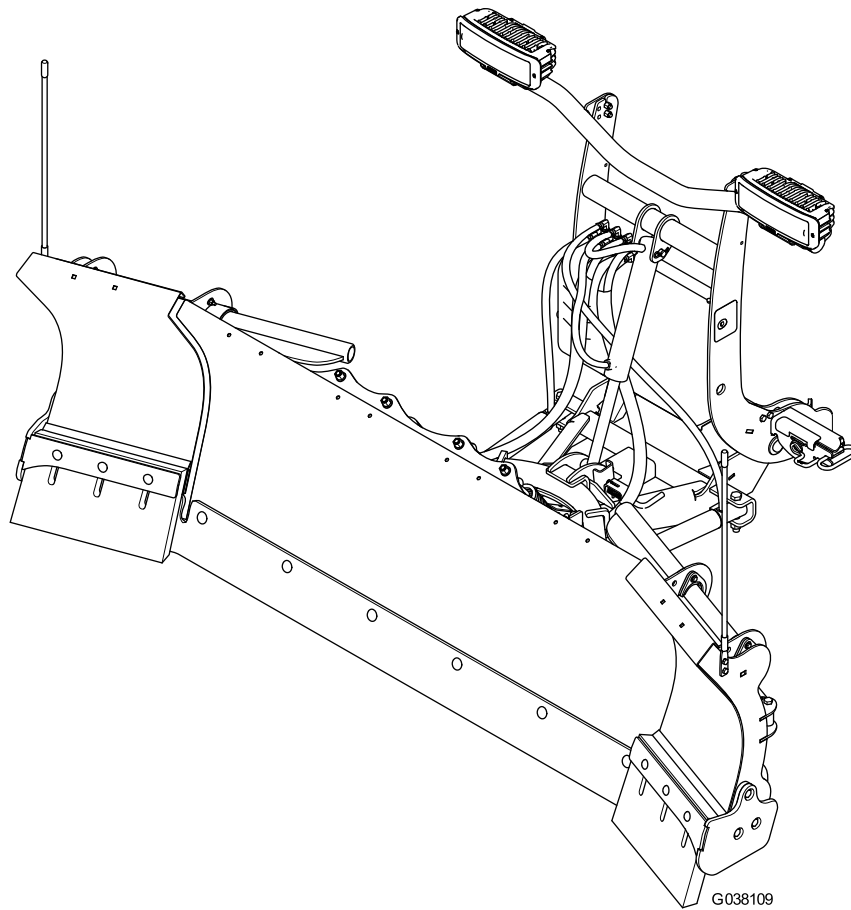

P.O. Box 787
Iron Mountain, MI 49801
United States

Installation Instructions

RT3 EXT Straight-Blade Plow



This product complies with all relevant European directives; for details, please see the separate product specific Declaration of Conformity (DOC) sheet.

BOSS Products limited consumer warranty and BOSS Products commercial warranty policies are located at www.BOSSPlow.com.

Patents pending.

Introduction

Note: Use this manual to assemble and install all BOSS EXT straight-blade plows. Illustrations may vary.

Read this information carefully to learn how to operate and maintain your product properly and to avoid injury and product damage. You are responsible for operating the product properly and safely.

Visit www.BOSSPlow.com for product safety and operation training materials, accessory information, help finding a dealer, or to register your product.

Whenever you need service, genuine BOSS parts, or additional information, contact an Authorized BOSS Dealer or BOSS Technical Service (1-800-286-4155) and have the model and serial numbers of your product ready. **Figure 1** identifies the location of the model and serial numbers on the product. Write the numbers in the space provided.

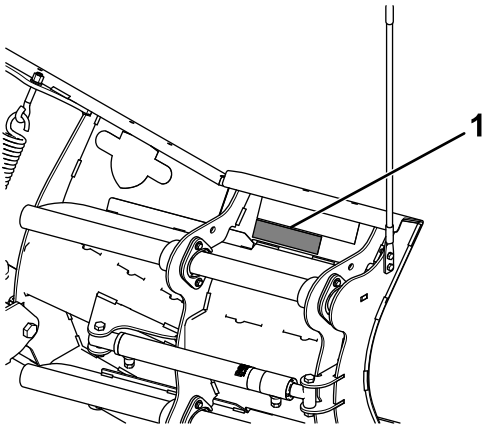

Figure 1

1. Model and serial number location

Date Purchased	_____
Model No.	_____
Serial No.	_____
Blade Crate Serial No.	_____

This manual identifies potential hazards and has safety messages identified by the safety-alert symbol (**Figure 2**), which signals a hazard that may cause serious injury or death if you do not follow the recommended precautions.



Figure 2

Safety-alert symbol

g000502

This manual uses 2 words to highlight information.

Important calls attention to special mechanical information and **Note** emphasizes general information worthy of special attention.

Contents

Safety	3
Preparation.....	3
Operation.....	3
Safety and Instructional Decals	4
Installation	7
Installing the Push Frame and Shock Absorber	7
Installing the Trip Springs and Coupler Tower	8
Installing the Hydraulic Hoses.....	9
Installing the Light Bar	11
Installing the Blade Guides and Filling the Hydraulic Reservoir.....	12
Installing the Wire Harness	13
Installing the Headlight Adapters	16
Mounting the Plow Controller	17
Adjusting the Pushbeam Height.....	18
Mounting the Snowplow.....	18
Adjusting the Angle of Attack	19
Aiming the Headlights.....	19
Product Overview	21
Controls	21
Specifications	22
Troubleshooting	23
Schematics	27

Safety

Improper use or maintenance by the operator or owner can result in injury. To reduce the potential for injury, comply with these safety instructions and always pay attention to the safety-alert symbol , which means *Caution, Warning, or Danger*—personal safety instruction. Failure to comply with the instruction may result in personal injury or death.

Preparation

- Read the *Owner's Manual* before operating or servicing the plow.
- Always follow the vehicle manufacturer's recommendations relating to snowplow installation. For recommended vehicle models, refer to the BOSS product selector tool at www.BOSSPlow.com.
- Ensure that only trained personnel install and perform maintenance on the equipment and hydraulic components.
- Never disable, remove, or relocate any sensors or other components related to the operation of the air bags in your vehicle.
- Keep your hands, feet, and clothing away from moving parts and mounting points.
- Ensure the plow is properly attached to the vehicle before moving it.
- To comply with federal regulations and to assure a safe vehicle, do not exceed the front gross-axle-weight rating (FGAWR), rear gross-axle-weight rating (RGAWR), and the gross-vehicle-weight rating (GVWR) at any time.
- Always wear appropriate personal protective equipment when operating and servicing the machine. Wear substantial, slip-resistant footwear, and cold-weather clothing.
- Use a 500 kg (1/2 ton) minimum lifting device to move heavy plow components.
- Material safety data sheets (MSDS) are available at www.BOSSPlow.com.

Operation

- Vehicles equipped with air bags are designed so that the air bags activate in a frontal collision equivalent to hitting a solid barrier (such as a wall) at approximately 22 km/h (14 mph) or more, or a frontal perpendicular collision with a parked car or truck of similar size at approximately 45 km/h (28 mph) or more. Careless or high-speed driving while plowing snow can deploy the air bag.
- When transporting the vehicle, position the plow so as not to block your vision or the plow headlights.
- Do not change the blade position when traveling.
- Do not exceed 64 km/h (40 mph) when transporting the plow.
- Do not exceed 22 km/h (14 mph) when plowing.
- Do not exceed 8 km/h (5 mph) when D-Force is activated (if equipped).
- Always lower the blade when the vehicle is not in use.
- Never put any part of your body between the plow and the vehicle.
- Do not operate the machine while ill, tired, or under the influence of alcohol or drugs.
- Use your full attention while operating the machine. Do not engage in any activity that causes distractions; otherwise, injury or property damage may occur.
- Always wear your seat belt while operating a motor vehicle.
- Due to the variety of equipment that you can install on the vehicle, do not exceed the front gross-axle-weight rating (FGAWR), rear gross-axle-weight rating (RGAWR), and the gross-vehicle-weight rating (GVWR) at any time. This may require weighing the vehicle and adding ballast as necessary. It may also limit the payload capacity of the vehicle.
- This machine has an operating sound level below 70 dBA.
- When transporting the machine, ensure that it is properly secured. Instructions are available at www.BOSSPlow.com.

Safety and Instructional Decals



Safety decals and instructions are easily visible to the operator and are located near any area of potential danger. Replace any decal that is damaged or missing.

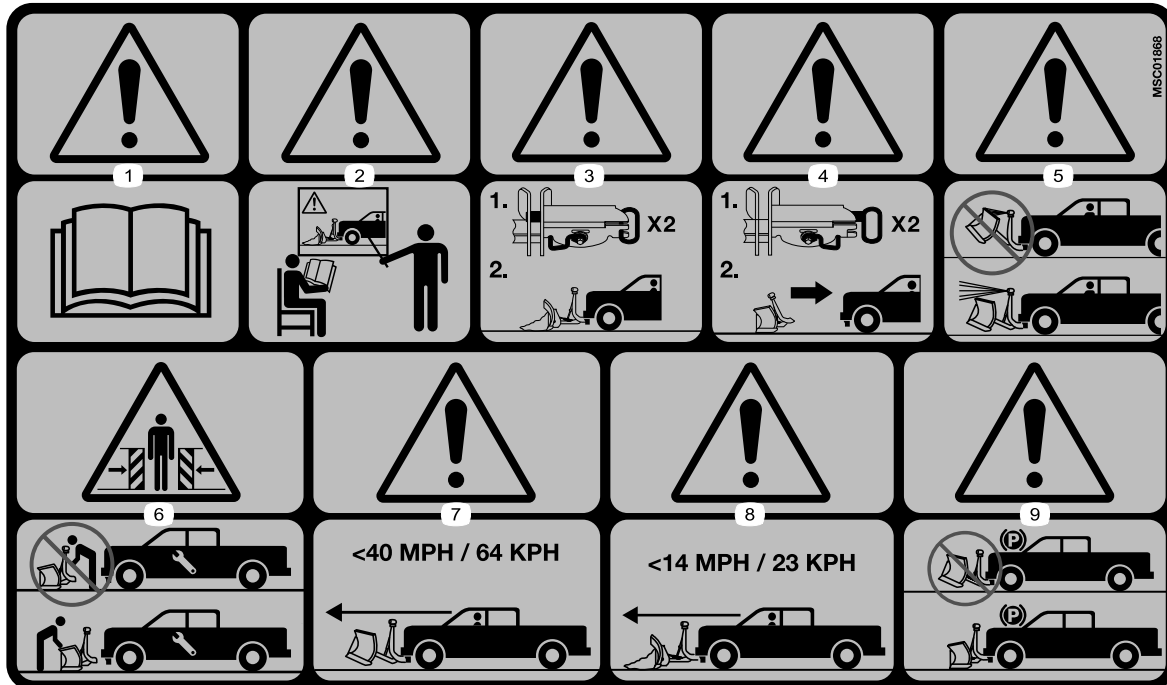

MSC01868

decalsc01868

1. Warning—read the *Owner's Manual*.
2. Warning—all operators should be trained before operating the machine.
3. Warning—coupler spring pins must be locked before plowing.
4. Warning—coupler spring pins must be unlocked to remove the plow.
5. Warning—do not block the vehicle headlights with the plow.
6. Crushing hazard—do not stand between the plow and vehicle during maintenance.
7. Warning—do not exceed 64 km/h (40 mph) when transporting the plow.
8. Warning—do not exceed 22 km/h (14 mph) when plowing.
9. Warning—lower the plow when the vehicle is not in use.

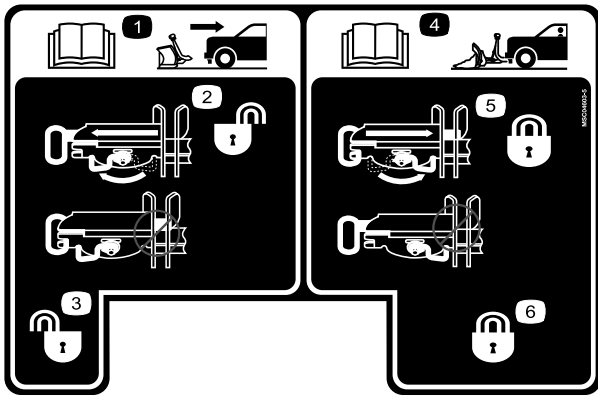

decalsmc04603-5

MSC04603-5

- | | |
|---|--|
| 1. Read the <i>Owner's Manual</i> for information on removing the plow. | 4. Read the <i>Owner's Manual</i> for information on attaching the plow. |
| 2. Coupler spring pin unlock | 5. Coupler spring pin lock |
| 3. Coupler spring pin unlock | 6. Coupler spring pin lock |

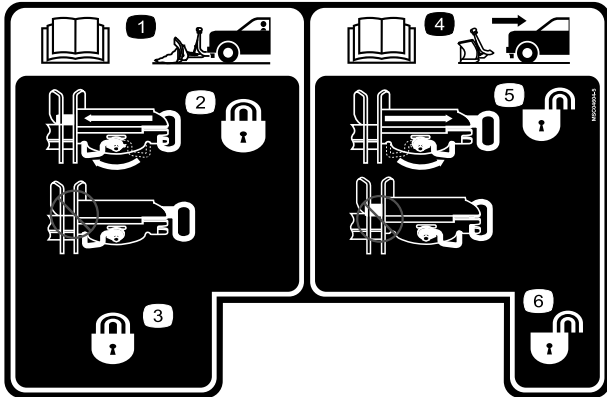

decalsmc04604-5

MSC04604-5

- | | |
|--|---|
| 1. Read the <i>Owner's Manual</i> for information on attaching the plow. | 4. Read the <i>Owner's Manual</i> for information on removing the plow. |
| 2. Coupler spring pin lock | 5. Coupler spring pin unlock |
| 3. Coupler spring pin lock | 6. Coupler spring pin unlock |

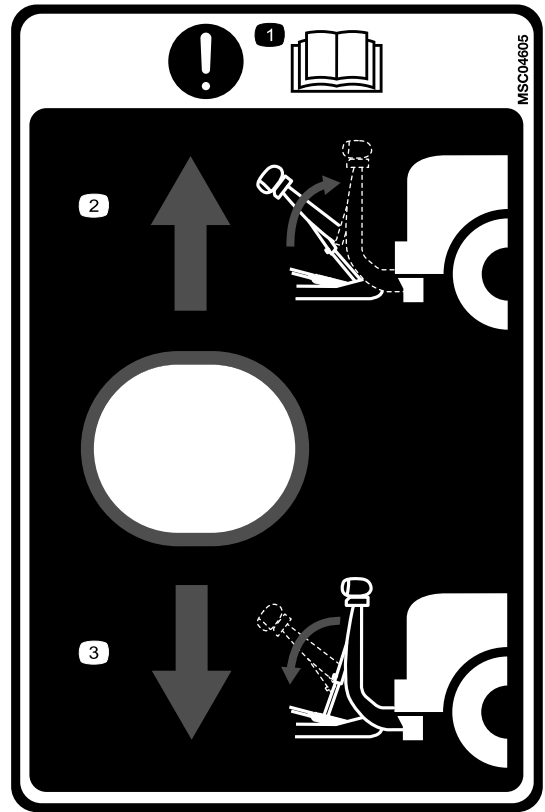

decalsmc04605

MSC04605

- | | |
|---|-----------------------------|
| 1. Important—read the <i>Owner's Manual</i> . | 3. Lower the coupler tower. |
| 2. Raise the coupler tower. | |

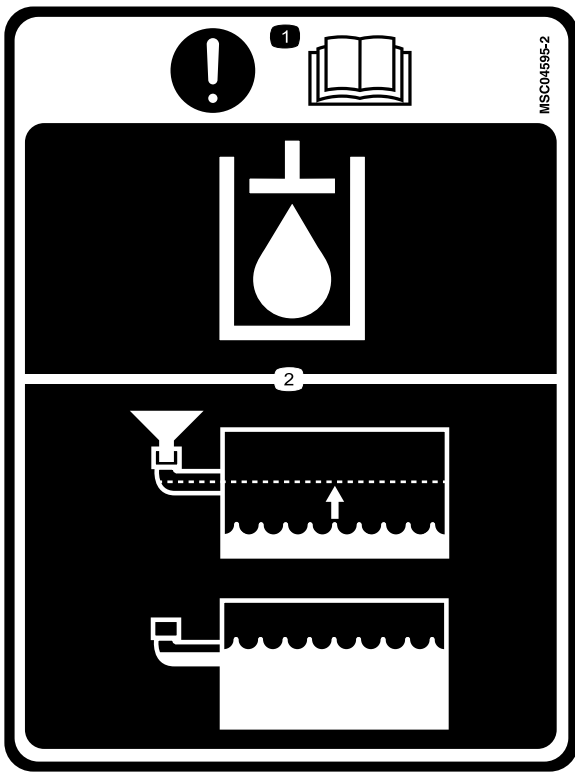

MSC04595-2

MSC04595

decalmsc04595

1. Important—read the *Owner's Manual*.
2. Fill the hydraulic fluid to the bottom of the fill elbow.

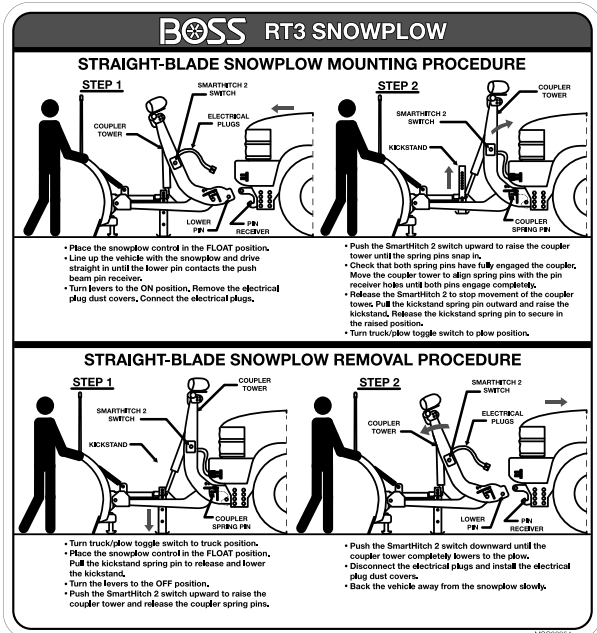

MSC06354

MSC06354

decalmsc06354

Installation

Determine the left and right sides of the machine from the normal operating position.

Installing the Push Frame and Shock Absorber

If desired, install optional plow shoes before starting this installation.

1. Attach the front of the push-frame assembly to the plow blade using 3 bolts (3/4 inch) and self-locking nuts (Figure 3).

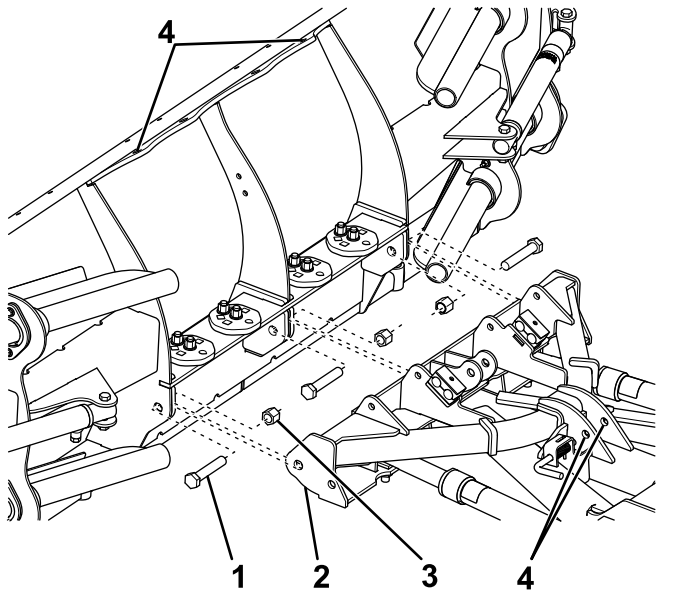

Figure 3

- | | |
|------------------------|--------------------------------|
| 1. Bolt (3/4 inch) | 3. Self-locking nut (3/4 inch) |
| 2. Push-frame assembly | 4. Lift point |

2. Pull the kickstand spring pin and insert the kickstand into the mounting bracket, then release the spring pin to lock the kickstand in place in the lowered position (Figure 4).

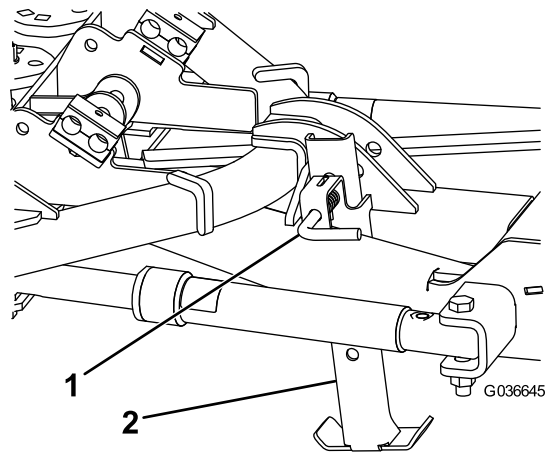

Figure 4

- | | |
|-------------------------|--------------|
| 1. Kickstand spring pin | 2. Kickstand |
|-------------------------|--------------|

3. Secure the end of the shock absorber to the push-frame assembly using a bolt (5/8 inch) and locknut as shown in Figure 5.

Note: Do not tighten the bolt and locknut at this time.

Note: Ensure that the bolt head is on the right side of the mounting bracket.

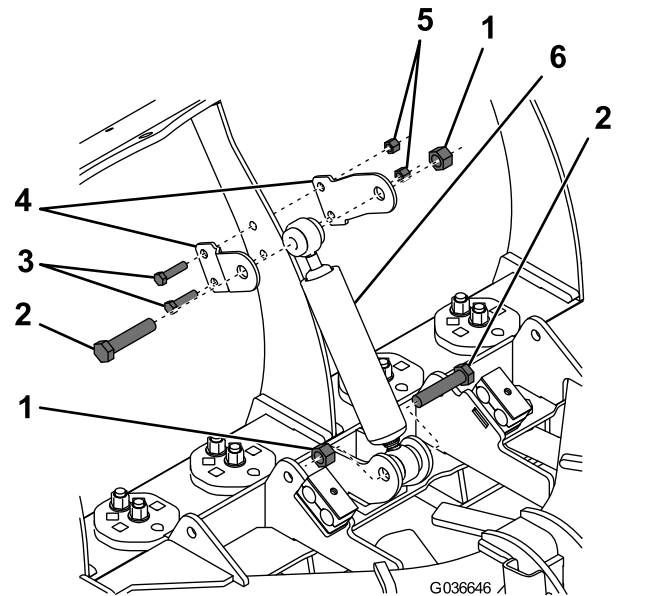

Figure 5

- | | |
|-----------------------------|--------------------------------|
| 1. Locknut (5/8 inch) | 4. Blade shock-mount |
| 2. Bolt (5/8 inch) | 5. Locknuts (3/8 x 1-1/2 inch) |
| 3. Bolts (3/8 x 1-1/2 inch) | 6. Shock absorber |

4. Attach the blade shock-mount to the top of the shock absorber using a bolt (5/8 inch) and locknut as shown in Figure 5.

Note: Do not tighten the bolt and locknut at this time.

- Slot the blade shock-mount onto the center rib of the plow and secure it using 2 bolts (3/8 x 1-1/2 inches) and locknuts (Figure 5).

Note: Do not tighten the bolts and locknuts at this time.

- Extend the shock absorber so that 6 mm (1/4 inch) of the rod is visible (Figure 5).
- Torque the 3/8 inch bolts on the shock mounting-bracket to 31 N·m (23 ft·lb).
- Tighten the 5/8 inch bolts on the top and bottom of the shock absorber until less than 12 mm (1/2 inch) of the bolt thread is visible.

Important: Do not overtighten.

Installing the Trip Springs and Coupler Tower

- Hook the 4 trip springs through the holes on the push-frame assembly (Figure 6).

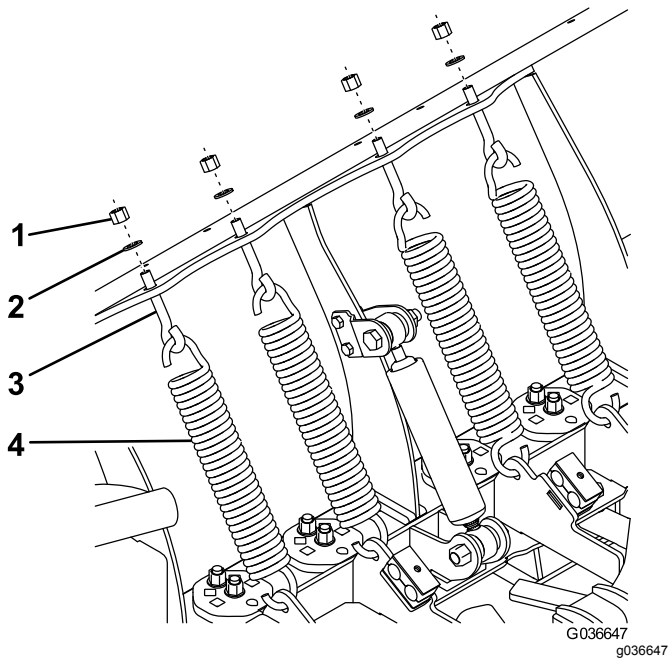

Figure 6

- Self-locking nut (1/2 inch)
- Washer (1/2 inch)
- Eyebolt
- Trip spring

- Hook the other ends of the trip springs to 4 eyebolts (Figure 6).
- Insert the threaded end of the eyebolts through the holes on the plow blade and secure them using 4 washers (1/2 inch) and 4 self-locking nuts (Figure 6).
- Tighten the self-locking nuts until there is a gap of 0.8 mm (1/32 inch) between the trip spring coils.

- Align the pivot holes of the coupler tower with the pivot holes on the push-frame assembly, and secure them as shown in Figure 7.

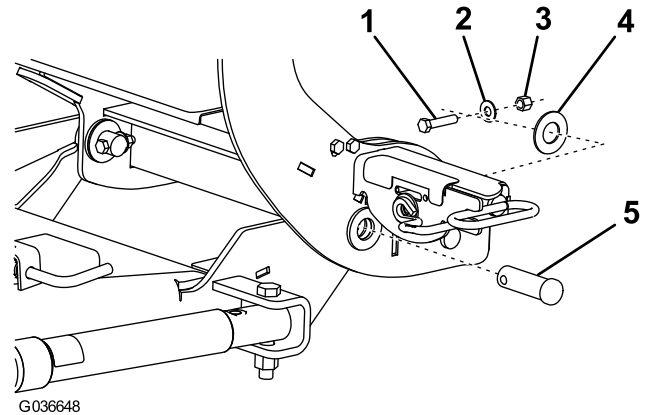

Figure 7

- Bolt (3/8 x 1-3/4 inch)
- Flat washer (3/8 inch)
- Locknut (3/8 inch)
- Flat washer (1 inch)
- Pivot pin

- Secure the rod end of the lift cylinder to the push-frame assembly using a clevis pin (5/8 inch) and hairpin cotter (Figure 8).

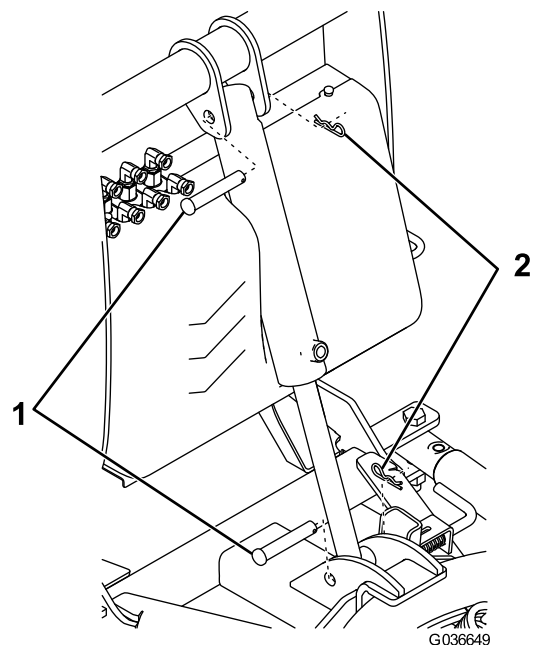

Figure 8

- Clevis pin (5/8 inch)
- Hairpin cotter

- Secure the free end of the lift cylinder to the coupler tower using a clevis pin and hairpin cotter (Figure 8).

Installing the Hydraulic Hoses

Refer to [Figure 9](#) when installing the hoses to the hydraulic shelf.

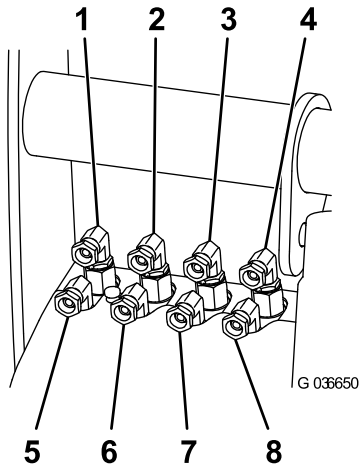

Figure 9

g036650

- | | |
|--|--|
| 1. C1 to the left push-frame cylinder | 5. C2 to the right push-frame cylinder |
| 2. Aux to the upper fitting on the lift cylinder | 6. L to the lower fitting on the lift cylinder |
| 3. XR2 to the outer fitting on the right wing-cylinder | 7. XR1 to the inner fitting on the right wing-cylinder |
| 4. XL2 to the outer fitting on the left wing-cylinder | 8. XL1 to the inner fitting on the left wing-cylinder |

1. Connect a 1.8 m (73-1/2 inch) hose to the XL2 port on the hydraulic shelf, and a 1.5 m (59-1/2 inch) hose to the XL1 port ([Figure 9](#)). Turn the fitting until it is finger tight, then turn it another 1/4 to 1/2 turn.

Important: Do not overtighten.

2. Slide the 2 hoses through 2 pieces of hose wrap as shown in [Figure 10](#).
3. Secure the hoses to the left hose-clamp using a bolt (5/16 x 2-1/2 inches) and nut between the 2 sections of hose wrap ([Figure 10](#)).
4. Using thread compound, install 90° fittings to the left wing extension cylinder ([Figure 10](#)).

Note: The fittings should point toward the center of the plow.

5. Connect the 1.5 m (59-1/2 inch) hose to the inner fitting on the left wing-cylinder ([Figure 10](#)). Turn the fitting until it is finger tight, then turn it another 1/4 to 1/2 turn.

Important: Do not overtighten.

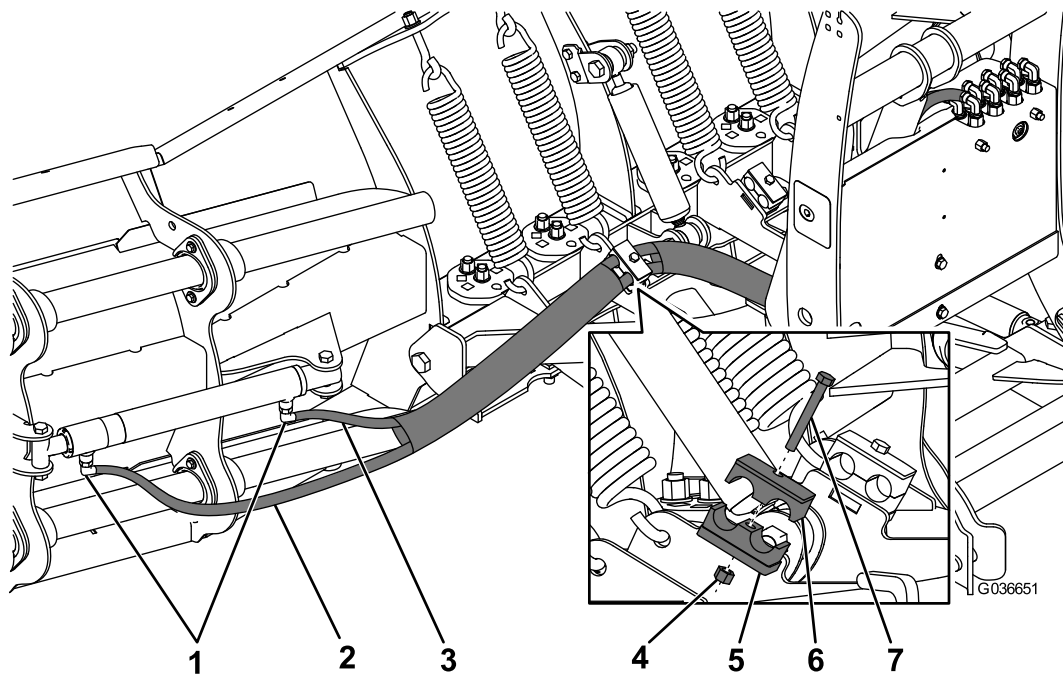

Figure 10

g036651

- | | |
|---|---|
| <ol style="list-style-type: none"> 1. 90° fittings 2. 1.8 m (73-1/2 inch) hose 3. 1.5 m (59-1/2 inch) hose 4. Nut (5/16 inch) | <ol style="list-style-type: none"> 5. Lower hose-clamp 6. Upper hose-clamp 7. Bolt (5/16 x 2-1/2 inches) |
|---|---|

6. Connect the 1.8 m (73-1/2 inch) hose to the outer fitting on the left wing-cylinder (Figure 10). Turn the fitting until it is finger tight, then turn it another 1/4 to 1/2 turn.

Important: Do not overtighten.

7. Repeat steps 1 through 6 for ports XR1 and XR2 on the right side of the machine.
8. Install the 45 cm (18 inch) hose to the L port on the hydraulic shelf and the lower fitting on the lift cylinder (Figure 11). Turn the fitting until it is finger tight, then turn it another 1/4 to 1/2 turn.

Important: Do not overtighten.

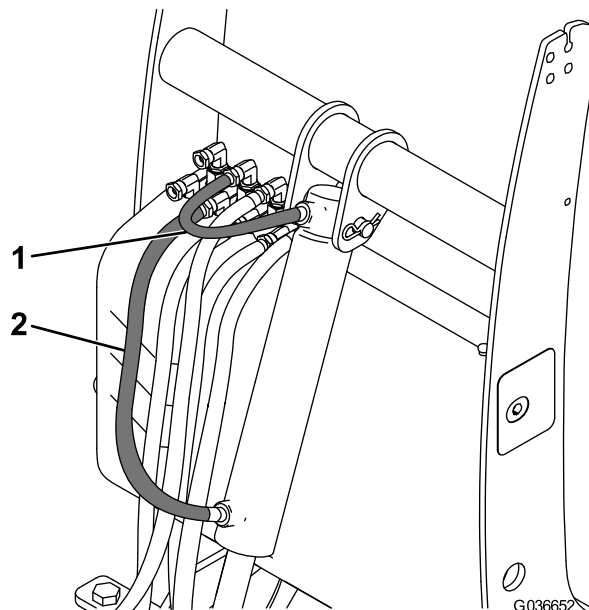

Figure 11

g036652

- | | |
|---|---|
| <ol style="list-style-type: none"> 1. 39 cm (15-1/2 inch) hose | <ol style="list-style-type: none"> 2. 45 cm (18 inch) hose |
|---|---|

9. Remove the plug on the upper fitting on the lift cylinder.
10. Install the 39 cm (15-1/2 inch) hose to the Aux port on the hydraulic shelf (Figure 11). Turn the fitting until it is finger tight, then turn it another 1/4 to 1/2 turn.

Important: Do not overtighten.

- Using thread compound, connect the other end of the hose to the upper fitting on the lift cylinder (Figure 11), and turn the fitting until it is finger tight, then turn it another 1-1/2 to 3 turns.

Important: Do not overtighten.

Important: Do not get thread-locking compound on the end of the hose as it will contaminate the hydraulic system.

- Install the 1 m (40 inch) hose to the C1 port on the hydraulic shelf, and turn the fitting until it is finger tight, then turn it another 1/4 to 1/2 turn.

Important: Do not overtighten.

- Using thread compound, connect the other end of the hose to the left push-frame cylinder (Figure 10), and turn the fitting until it is finger tight, then turn it another 1-1/2 to 3 turns.

Important: Do not overtighten.

Important: Do not get thread-locking compound on the end of the hose as it will contaminate the hydraulic system.

- Install the 86 cm (34 inch) hose to the C2 port on the hydraulic shelf and turn the fitting until it is finger tight, then turn it another 1/4 to 1/2 turn.

Important: Do not overtighten.

- Using thread compound, connect the other end of the hose to the right push-frame cylinder, and turn the fitting until it is finger tight, then turn it another 1-1/2 to 3 turns.

Important: Do not overtighten.

Important: Do not get thread-locking compound on the end of the hose as it will contaminate the hydraulic system.

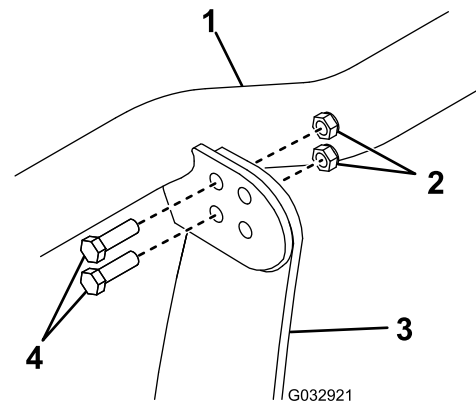

Figure 12

- | | |
|---------------------------------|-----------------------------|
| 1. Light bar | 3. Coupler tower |
| 2. Self-locking nuts (3/8 inch) | 4. Bolts (3/8 x 1-1/4 inch) |

- Ensure that the end caps are installed on the ends of the light bar (Figure 13).

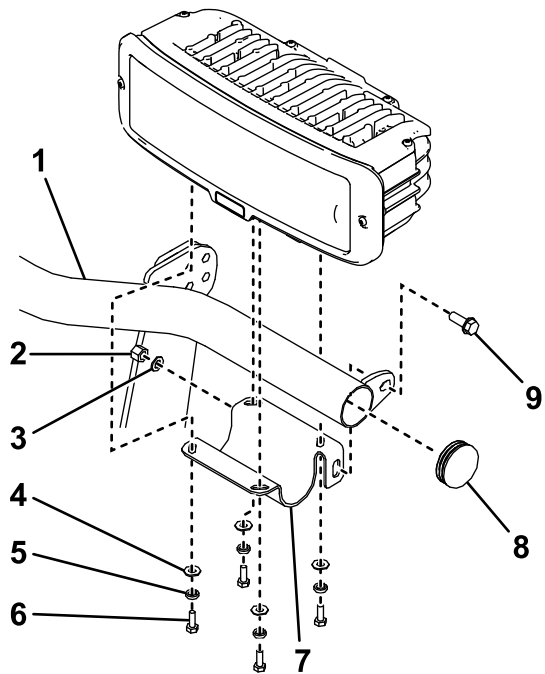

Figure 13

- | | |
|-----------------------------|------------------------------------|
| 1. Light bar | 6. Bolt (1/4 inch) |
| 2. Nylon locknut (3/8 inch) | 7. Headlight bracket |
| 3. Flat washer (3/8 inch) | 8. End cap |
| 4. Flat washer (1/4 inch) | 9. Flange-head bolt (3/8 x 1 inch) |
| 5. Split lock washer | |

- Secure the left headlight-bracket to the light bar using a flange-head bolt (3/8 x 1 inch), a flat washer, and a nylon locknut (Figure 13).

Important: Do not use thread locking compound on these bolts.

Note: Do not tighten the fasteners at this time.

Installing the Light Bar

- Secure the light bar to the top of the coupler tower through the rear holes using 4 bolts (3/8 x 1-1/4 inch) and self-locking nuts (3/8 inch) (Figure 12). Torque the bolts to 31 N·m (23 ft-lb).

Note: If the light bar or plow headlights comes in contact with the hood of your vehicle, install the bar using the front holes.

- Secure the left headlight to the headlight bracket using 4 bolts (1/4 inch), split lock washers, and flat washers (Figure 13).

Important: Do not use thread locking compound on these bolts.

Note: Do not tighten the fasteners at this time.

- Repeat steps 3 and 4 for the right headlight bracket and headlight.
- Insert the headlight connectors on the wire harness to the back of the headlight housing (Figure 14). The short length connects to the left headlight and the long length connects to the right headlight.

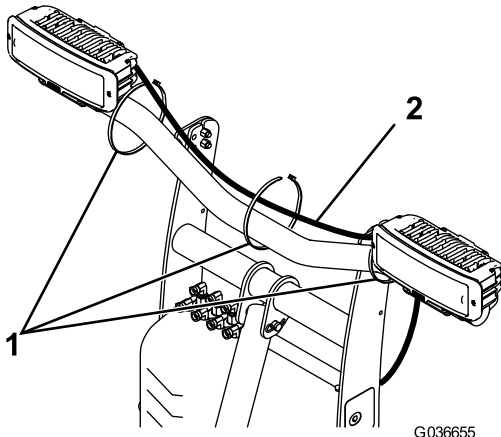

Figure 14

- Cable ties
- Short wire harness

- Secure the wire harness to the light bar using 3 cable ties as shown in Figure 14.

Installing the Blade Guides and Filling the Hydraulic Reservoir

- Attach the blade guides to the plow blade using 4 bolts (5/16 x 1 inch) and 4 self-locking nuts (Figure 15).

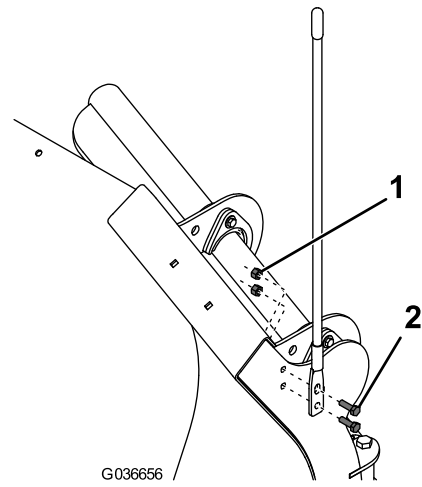

Figure 15

- Self-locking nut (5/16 inch)
- Blade guide
- Bolt (5/16 x 1 inch)

- Ensure that the lift cylinder is completely collapsed.

Note: The lights should tilt forward.

- Remove the fill cap from the hydraulic reservoir (Figure 16).

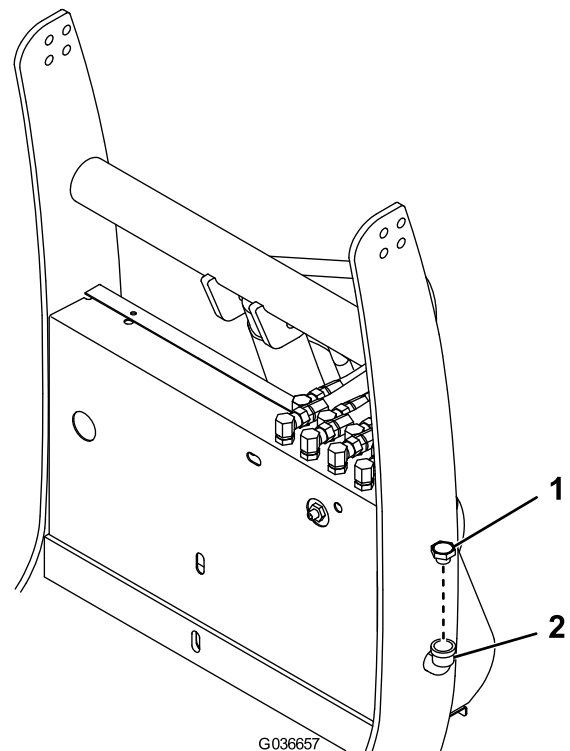

Figure 16

- Fill cap
- Hydraulic reservoir

- Slowly fill the reservoir with BOSS high-performance hydraulic fluid until it accepts no more.

Note: The reservoir holds approximately 1.9 L (2 US qt) of hydraulic fluid.

5. Install the previously removed fill cap.

Installing the Wire Harness

⚠ DANGER

Vehicle engines contain moving parts and can become extremely hot, capable of causing severe burns and serious bodily harm.

Shut off the engine and allow it sufficient time to cool down before installing this kit.

⚠ DANGER

Vehicle batteries can cause dangerous electrical shocks that could lead to severe burns or death.

Disconnect your battery before installing this kit. Remove the negative cable first, then remove the positive cable.

Note: Apply dielectric grease to all electrical connections.

Note: Some vehicles require a turn signal relay kit. Contact your Authorized BOSS Dealer for more information.

Note: If your vehicle requires a headlight adapter kit, refer to [Installing the Headlight Adapters](#) (page 16).

1. Disconnect the wire harness plug from the back of the left vehicle headlight ([Figure 17](#)).

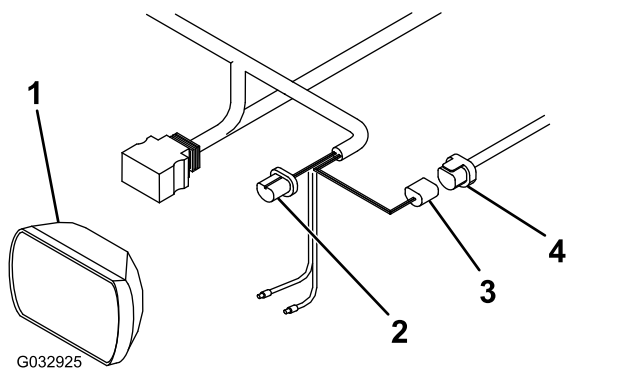

Figure 17

1. Vehicle headlight
2. Blue plug
3. Black plug
4. Vehicle wire-harness plug

2. Connect the blue plug from the long wire harness to the back of the left vehicle headlight ([Figure 17](#)).

3. Connect the black plug from the long wire harness to the previously disconnected plug on the vehicle wire harness ([Figure 17](#)).
4. Repeat steps 1 through 3 on the right vehicle headlight.
5. Connect the pink wire from the long wire harness to the right turn signal wire using a splice connector ([Figure 18](#)).

Important: Identify the circuit with a test lamp before splicing into any electrical circuit to prevent vehicle damage.

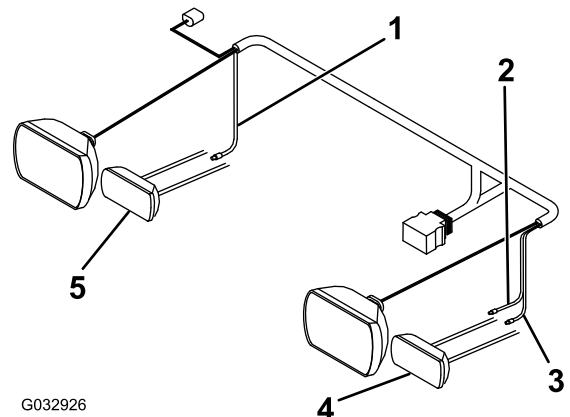

Figure 18

1. Pink wire
2. Violet wire
3. Yellow wire
4. Left turn signal
5. Right turn signal

6. Connect the violet wire from the long wire harness to the left turn signal wire using a splice connector ([Figure 18](#)).
7. Connect the yellow wire from the long wire harness to the left park light wire using a splice connector ([Figure 18](#)).

8. Ensure that the vehicle firewall is clear of obstructions.
9. Drill a 3 cm (1-1/4 inch) diameter hole through the firewall on the driver side of the vehicle.

Note: The hole should be in an easily accessible area.

10. Insert the split rubber grommet into the hole.
11. Pull the plow controller connector, black/red wire, and 2 black wires into the vehicle cab through the hole in the firewall ([Figure 19](#)).

Important: Ensure that all wiring is secured in a position that avoids hot or moving parts to prevent damage to the vehicle or plow.

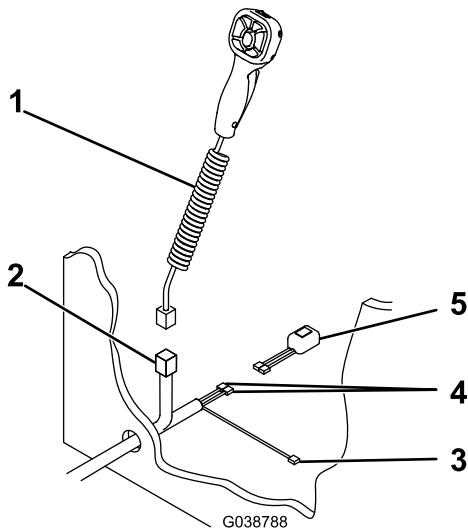

Figure 19

- | | |
|-------------------------|----------------------------|
| 1. Plow controller | 4. Black wires |
| 2. Controller connector | 5. Headlight toggle switch |
| 3. Black/red wire | |

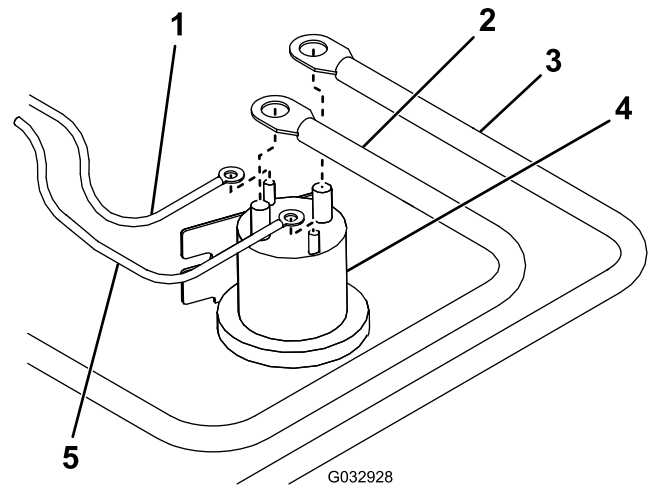

Figure 20

- | | |
|---------------------------|------------------|
| 1. White/black wire | 4. Pump solenoid |
| 2. Battery cable | 5. Brown wire |
| 3. Red power/ground cable | |

12. Connect the 2 black wires to the headlight toggle switch (Figure 19).

13. Determine where you will mount the headlight toggle switch and clean the area thoroughly.

Note: Allow the area to dry completely after cleaning.

14. Remove the adhesive backing and press the toggle switch to the clean area of the dashboard for 30 seconds.

15. Plug the controller connector into the plow controller.

16. Mount the plow controller; refer to [Mounting the Plow Controller](#) (page 17).

17. Connect the black/red wire to a keyed 12 V + ignition source.

Note: Connecting the wire to a source that is not keyed can cause the battery to drain.

18. Connect the white/black wire from the wire harness to the small post on the pump solenoid (Figure 20).

19. Connect the brown wire from the wire harness to the other small post on the pump solenoid (Figure 20).

Note: The wires may go on either small post, but should not share a post.

20. Mount the pump solenoid inside the engine compartment of the vehicle, ensuring that it stays in an upright position and does not contact the body, hood, or other conductive material on the vehicle.

21. Connect the red power/ground cable to the large post on the pump solenoid (Figure 20).

22. Connect the battery cable to the other large post on the pump solenoid (Figure 20).

Note: The wires may go on either large post, but should not share a post.

23. Connect the black power/ground cable to the negative (-) battery terminal (Figure 21).

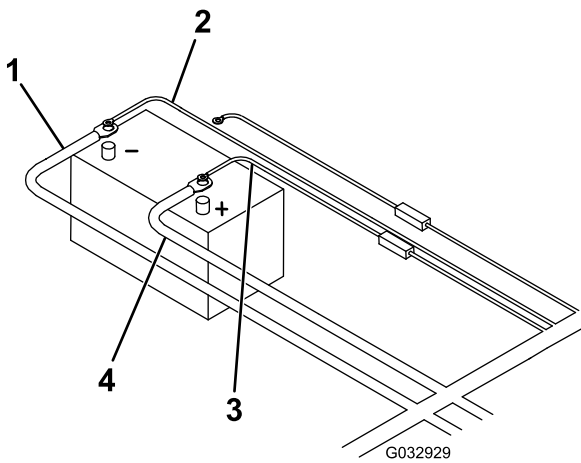

Figure 21

- 1. Black power/ground cable
- 2. Brown wire
- 3. Red/white fused wire
- 4. Red fused wire
- 5. Red power/ground cable

- 24. Connect the brown wire to the negative (-) battery terminal (Figure 21).
- 25. Connect the free end of the battery cable to the positive (+) battery terminal (Figure 21).
- 26. Connect the red, fused wire and the red/white fused wire to the positive (+) battery terminal (Figure 21).
- 27. Mount the truck-side, wire harness plow connector to the lower part of the bumper using the control harness mounting bracket (Figure 22).

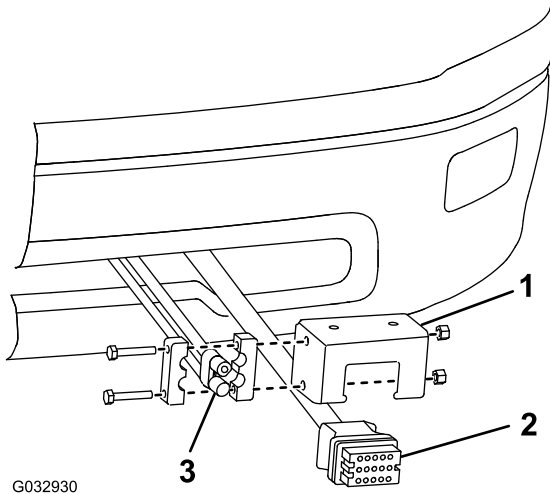

Figure 22

- 1. Control-harness mounting bracket
- 2. Plow connector
- 3. Power/ground connector bracket

- 28. Mount the black and red power/ground connector to the control harness mounting bracket (Figure 22).

- 29. Mount the relay pack to the inside of the engine compartment using a sheet-metal screw (Figure 23).

Note: Ensure that the relay pack is mounted in the upright position.

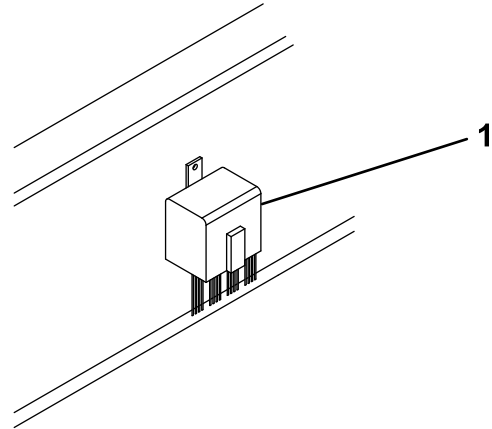

Figure 23

- 1. Relay pack

- 30. Locate the vehicle option connector and align it according to the table below:

Note: If your vehicle is not listed in the table, use the standard orientation.

Note: If the vehicle option connector is not properly oriented, the lights on the plow do not function correctly.

Models	Orientation
1992 and newer Ford models 1988 and newer GM models 2003 and newer Dodge models Dodge models with a 4-headlight system	<p>Standard Orientation</p> <p>1. Red/yellow wire 2. White/yellow wire</p> <p>3. Red/yellow wire 4. White/yellow wire</p>
1987 and older GM models with a 4-headlight system 1987 to 1991 Ford models (9004 bulb) 1994 to 2002 Dodge models with a 2-headlight system (9004 bulb)	<p>Reverse Orientation</p> <p>1. White/yellow wire 2. Red/yellow wire</p> <p>3. Red/yellow wire 4. White/yellow wire</p>

- 31. Connect the red/white wire to the battery according to the table below:

Note: If the red/white wire is installed incorrectly, the low beams do not illuminate when the plow high-beams are on.

Models	Wire Placement
1999 to 2002 Chevrolet and GMC models 1999 to 2002 Dodge models 2000 to 2006 Toyota models	Negative (-) battery terminal
All other vehicles	Positive (+) battery terminal

32. Secure the wire harness.
33. Attach the snowplow to the vehicle; refer to [Mounting the Snowplow \(page 18\)](#).
34. Test the wire harness installation as follows:

Note: Turn the ignition to the ON position before testing.

Note: If any of the lights fail to work, check the wiring and make any corrections.

- A. To test the vehicle low-beam lights, do the following:
 - Switch the vehicle headlights to the ON position.
 - Switch the plow headlight toggle switch to the TRUCK position.
 - Ensure that the low-beam light indicator on the vehicle is illuminated.

Only the vehicle low-beam lights should be illuminated.

- B. To test the vehicle high-beam lights, do the following:
 - Switch the vehicle headlights to the HIGH-BEAM position.
 - Switch the plow headlight toggle switch to the TRUCK position.
 - Ensure that the high-beam light indicator on the vehicle is illuminated.

Only the vehicle high-beam lights should be illuminated.

- C. To test the plow low-beam lights, do the following:
 - Switch the vehicle headlights to the ON position.
 - Switch the plow headlight toggle switch to the PLOW position.
 - Ensure that the low-beam light indicator on the vehicle is illuminated.

Only the plow low-beam lights should be illuminated.

- D. To test the plow high-beam lights, do the following:
 - Switch the vehicle headlights to the HIGH-BEAM position.

- Switch the plow headlight toggle switch to the PLOW position.
- Ensure that the high-beam light indicator on the vehicle is illuminated.

Only the plow high-beam and low-beam lights should be illuminated.

- E. To test the plow and vehicle turn signals, do the following:
 - Activate the left or right vehicle turn signal.
 - Ensure that the appropriate vehicle turn-signal indicator is illuminated.

Both the vehicle and plow turn signals should flash.

- F. To test the plow and vehicle park lights, activate the vehicle park lights.

All the plow and vehicle park lights should be on.

Installing the Headlight Adapters

Optional

For Two-Headlight Vehicles

1. Disconnect the wire harness plug from the back of the left vehicle headlight ([Figure 24](#)).

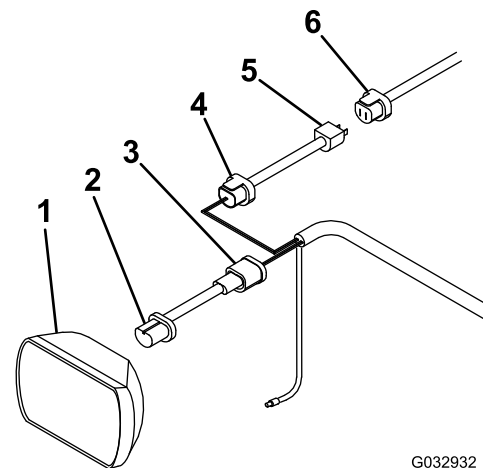

G032932

g032932

Figure 24

- | | |
|----------------------|------------------------------|
| 1. Vehicle headlight | 4. Blue plug |
| 2. Headlight adapter | 5. Headlight adapter |
| 3. Black plug | 6. Vehicle wire-harness plug |
-
2. Connect the headlight adapter to the back of the left vehicle headlight ([Figure 24](#)).
 3. Connect the black plug from the headlight adapter to the long wire harness ([Figure 24](#)).

4. Connect the blue plug from the headlight adapter to the blue plug on the long wire harness (Figure 24).
5. Connect the free end of the headlight adapter to the previously disconnected plug on the vehicle wire harness (Figure 24).
6. Repeat steps 1 through 5 on the right vehicle headlight.
7. Continue the wire harness installation from step 5 of [Installing the Wire Harness \(page 13\)](#).
8. Continue the wire harness installation from step 5 of [Installing the Wire Harness \(page 13\)](#).

For Four-Headlight Vehicles

1. Disconnect the wire harness plugs from the back of the left vehicle headlights (Figure 25).

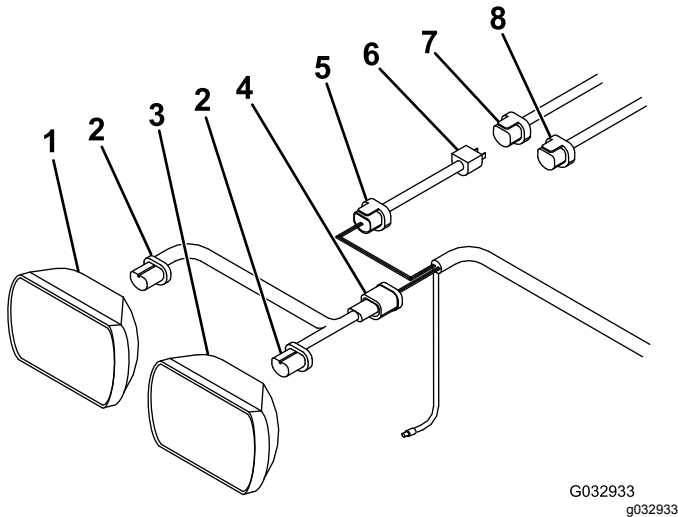

Figure 25

- | | |
|----------------------------|---------------------------|
| 1. Outer vehicle headlight | 5. Blue plug |
| 2. Headlight adapter | 6. Headlight adapter |
| 3. Inner vehicle headlight | 7. Vehicle low-beam plug |
| 4. Black plug | 8. Vehicle high-beam plug |

2. Connect the 2 ends of the headlight adapter to the back of the left vehicle headlights (Figure 25).
3. Connect the black plug from the headlight adapter to the long wire harness (Figure 25).
4. Connect the blue plug from the headlight adapter to the blue plug on the long wire harness (Figure 25).
5. Connect the free end of the headlight adapter to the previously disconnected low-beam plug on the vehicle wire harness (Figure 25).
6. Grease, tuck, and secure the previously disconnected high-beam plug on the vehicle wire harness (Figure 25).

Note: You will not use this connector.

7. Repeat steps 1 through 6 on the right vehicle headlights.

Mounting the Plow Controller

⚠ DANGER

The controller could cause serious injury if contacted during a crash.

Mount the controller in a location where vehicle occupants will not contact during a crash.

Note: Mount the controller in the cab in a dry area where it does not interfere with vehicle operation or visibility.

Important: Do not install the swivel mount when temperatures are below 16°C (60°F).

1. Determine the mounting location for the controller.
2. Clean the location with the provided alcohol wipe and dry it with a cloth or paper towel.
3. Clean the back of the swivel mount (Figure 26) with the alcohol wipe and then dry it.

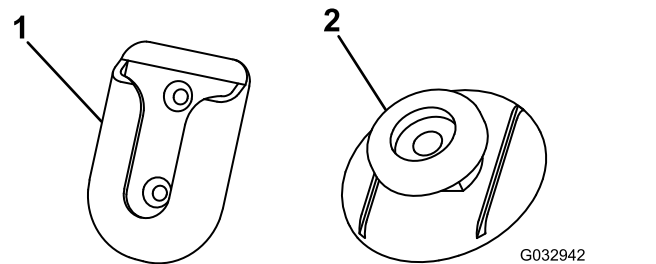

Figure 26

1. Swivel mount
2. Mounting tab

4. Remove the backing from 1 side of the adhesive and apply it to the back of the swivel mount.
5. Remove the remaining backing from the swivel-mount adhesive and press the swivel mount to the clean area of the dashboard for 30 seconds.

Important: Once the mount is placed, you cannot remove it without destroying the adhesive.

6. Clean the back of the controller with the alcohol wipe and then dry it.
7. Remove the backing from 1 side of the adhesive and apply it to the back of the mounting tab (Figure 26).

8. Remove the remaining backing from the controller adhesive and press the mounting tab to the controller for 30 seconds.
9. Let the swivel mount rest unused for 72 hours before sliding the controller into the mounting bracket.

Important: Mounting the controller immediately may cause the adhesive to fail.

10. Continue the wire harness installation from step 17 of [Installing the Wire Harness \(page 13\)](#).

Adjusting the Pushbeam Height

Optional

1. Measure the distance from the ground to the coupler spring-pin holes on the undercarriage pushbeam ([Figure 27](#)). The measurement should match the height listed for your plow in [Specifications \(page 22\)](#).
2. If the pushbeam is not at the correct height, remove the fasteners securing the pushbeam to the undercarriage ([Figure 27](#)).
3. Move the pushbeam up or down and secure it with the previously removed hardware.
4. Torque the fasteners to 76 N·m (56 ft-lb).

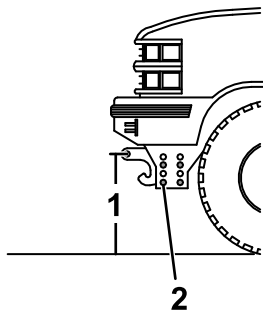

Figure 27

g230889

1. Measure this distance.
2. Fastener

Mounting the Snowplow

Note: The vehicle must be running before starting this procedure.

1. Activate the FLOAT feature on your plow controller.
2. Line up the vehicle with the snowplow and slowly drive forward until the lower pin contacts the push-beam pin receiver ([Figure 28](#)).

Note: Ensure that the pushbeam is at the correct height for your plow. Refer to

[Specifications \(page 22\)](#) for the recommended pushbeam height. Refer to [Adjusting the Pushbeam Height \(page 18\)](#) if the pushbeam is not at the correct height.

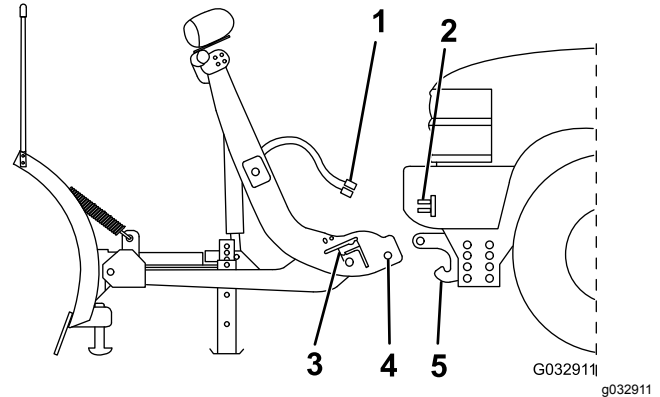

Figure 28

1. Plow wire harness
2. Vehicle wire harness
3. Coupler
4. Lower pin
5. Pin receiver

3. Turn the levers on the couplers to the ON position ([Figure 29](#)).

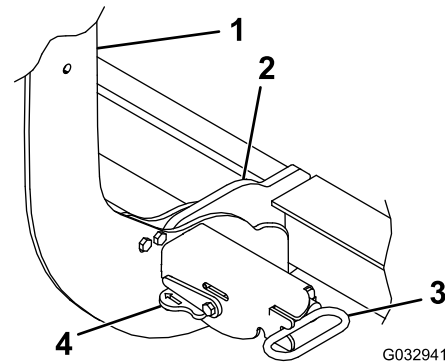

Figure 29

g032941

1. Coupler tower
2. Pin receiver
3. Coupler spring-pin
4. Coupler lever

4. Remove the electrical-plug dust-covers and connect the plow wire harness to the vehicle wire harness ([Figure 28](#)).
5. Push the SmartHitch2 switch on the side of the coupler tower upward and raise the tower until the coupler spring pins snap in ([Figure 30](#)).

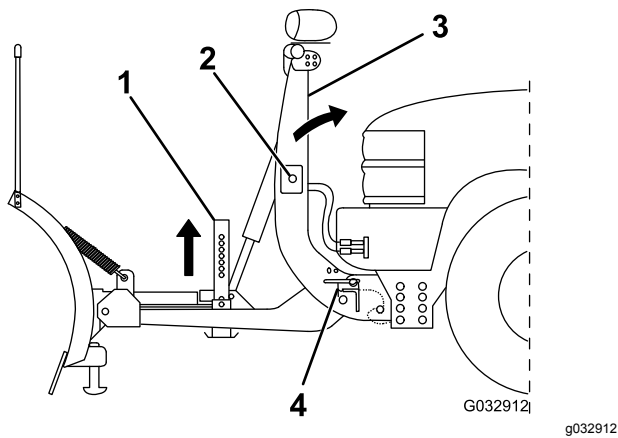

Figure 30

- | | |
|-----------------------|-----------------------|
| 1. Kickstand | 3. Coupler tower |
| 2. SmartHitch2 switch | 4. Coupler spring pin |

6. Ensure that both coupler spring pins have fully engaged the coupler (Figure 29).

Note: Move the coupler tower until the spring pins engage completely.

7. Pull the kickstand spring pin outward and raise the kickstand, then release the spring pin to secure it (Figure 30).
8. Switch the headlight toggle switch to the PLOW position.

Adjusting the Angle of Attack

1. Park the vehicle on a level surface and lower the plow completely. If the plow is not flush against the ground, adjust the angle of attack.
2. Loosen the trip springs.
3. On the cams, remove the bolt in the square hole and loosen the bolt in the center (Figure 31).

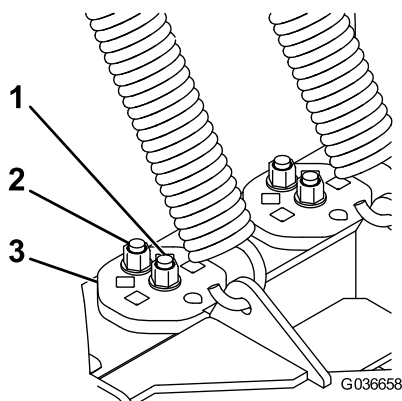

Figure 31

- | | |
|-------------------------|--------|
| 1. Center bolt (loosen) | 3. Cam |
| 2. Square bolt (remove) | |

4. Rotate the cam clockwise to angle the bottom of the blade back. Rotate the cam counterclockwise to angle the bottom of the blade forward.

Note: Use a 1/2 inch ratchet to help rotate the cams.

5. Insert the previously removed bolt, and torque it to 76 N·m (56 ft-lb).
6. Tighten the center bolt, and torque it to 76 N·m (56 ft-lb).
7. Tighten the trip springs until there is a gap of 0.8 mm (1/32 inch) between the trip spring coils.

Aiming the Headlights

Important: Certify that the installation of the snowplow lights conforms to applicable federal motor vehicle safety standards.

1. Park the vehicle on a level surface 7.5 m (25 ft) away from a matte white screen or garage door.

Note: The screen should be perpendicular to both the ground and the front of the vehicle.

2. Ensure that the vehicle is equipped for normal operation with the snowplow attached and in the raised position.
3. Perform the following actions to ensure optimal headlight alignment:
 - Remove any ice or mud from under the fenders.
 - Ensure that all tires are fully and evenly inflated.
 - Check vehicle springs for sag or broken leaves.
 - Check the function of any level ride controls.
 - Stabilize the suspension by rocking the vehicle sideways.
 - Ensure that there is no load in the vehicle other than the driver.
 - Clean the headlights and matte white screen.
4. Mark the vertical vehicle centerline on the screen (Figure 32).

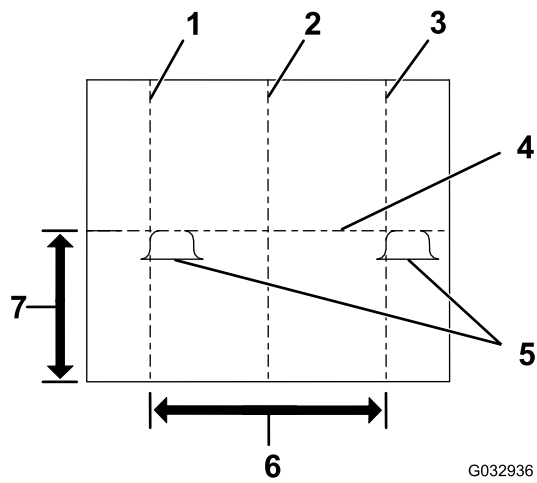

G032936

g032936

Figure 32

- | | |
|--|--|
| 1. Vertical left headlight centerline | 5. Brightest points |
| 2. Vehicle centerline | 6. Distance between headlight centers |
| 3. Vertical right headlight centerline | 7. Distance from ground to headlight centers |
| 4. Horizontal headlight centerline | |

-
5. Mark the vertical headlight centerline on the screen (Figure 32).
 6. Mark the horizontal headlight centerline on the screen (Figure 32).

Note: The horizontal headlight centerline should be the distance from the ground to the center of the headlight.

7. Adjust the plow headlights until the brightest part of the plow low-beam lights are aligned as shown in Figure 32.
8. Tighten the 4 bolts (1/4 x 3/4 inch) securing each headlight to the headlight brackets and torque them to 8 N·m (6 ft-lb).

Important: Do not use thread locking compound on these bolts.

9. Tighten the bolt (3/8 x 1 inch) securing each headlight-bracket to the light bar and torque them to 31 N·m (23 ft-lb).

Important: Do not use thread locking compound on these bolts.

Product Overview

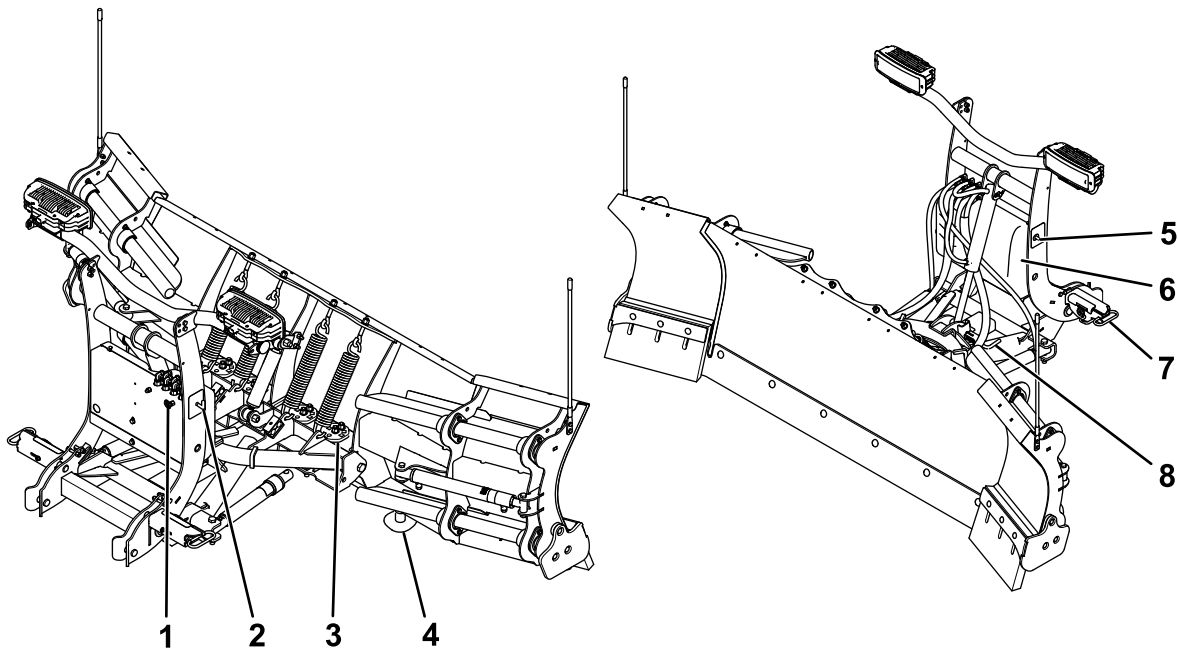

Figure 33

g230573

1. Hydraulic flow-control valve
2. Hydraulic reservoir fill elbow
3. Cam
4. Plow shoe
5. SmartHitch2 switch
6. Coupler-tower cover
7. Spring pin
8. Kickstand

Controls

Become familiar with all the controls before you operate the plow.

SmartHitch2 Switch

The SmartHitch2 switch controls the movement of the coupler tower to facilitate plow attachment and removal. With the controller in the Float mode, press the switch up to raise the tower and down to lower the tower.

Spring Pins

The spring pins secure the plow to the vehicle pushbeam. Turn the levers toward the coupler tower to lock the spring pins. Turn the levers away from the coupler tower to unlock the spring pins.

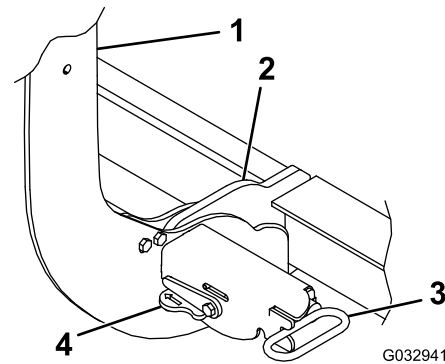

Figure 34

G032941

g032941

1. Coupler tower
2. Pin receiver
3. Spring pin
4. Lever

Headlight Toggle Switch

The headlight toggle switch controls which set of headlights is being used. Move the switch to the TRUCK position to use the headlights on the vehicle. Move the switch to the PLOW position to use the headlights on the plow.

SmartTouch2 Controller

The SmartTouch2 controller operates the movement of the snowplow.

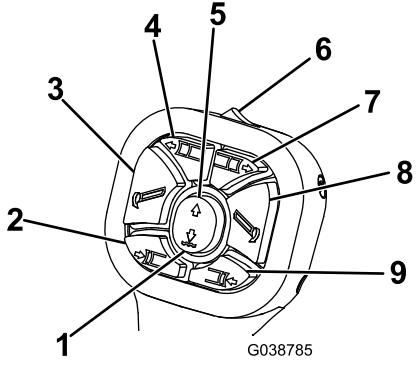

Figure 35

- | | |
|-----------------------------|------------------------------|
| 1. Lower/Float button | 6. On/Off switch |
| 2. Left wing retract button | 7. Right wing extend button |
| 3. Left button | 8. Right button |
| 4. Left wing extend button | 9. Right wing retract button |
| 5. Raise button | |

- On/Off switch—turns the plow controller on and off. A green light illuminates when the controller is on.

Note: Turn off the controller when not in use to prevent accidental activation of the plow.

- Raise button—raises the plow blade. Pressing the button quickly twice automatically raises the blade.
- Lower/Float button—lowers the plow blade and activates the FLOAT feature. Pressing the button quickly twice or holding it for 2 seconds automatically lowers the blade and activates the FLOAT feature, allowing the plow blade to follow the contour of the ground. A red light illuminates when the FLOAT feature is active.

- Left button—angles the plow blade to the left
- Right button—angles the plow blade to the right
- Left wing extend button—extends the left plow wing
- Right wing extend button—extends the right plow wing
- Left wing retract button—retracts the left plow wing
- Right wing retract button—retracts the right plow wing
- Sleep mode—If you do not use the controller for 20 minutes, it enters sleep mode and the controller lights flash green and red. Turn off the controller to deactivate the sleep mode.

Kickstand

Pull the kickstand spring pin to raise and lower the kickstand.

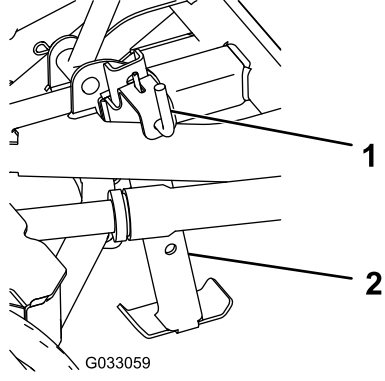

Figure 36

- | | |
|-------------------------|--------------|
| 1. Kickstand spring pin | 2. Kickstand |
|-------------------------|--------------|

Specifications

Blade width (wings retracted)	2.44 m (96 inches)
Blade width (wings expanded)	3.05 m (120 inches)
Blade height	76 cm (30 inches)
Recommended push beam height	39.3 cm (15-1/2 inches)
Weight	440 kg (970 lb)

Troubleshooting

Problem	Possible Cause	Corrective Action
The pump motor does not run.	<ol style="list-style-type: none"> 1. The power/ground cables or control cables are not connected. 2. The pump motor has failed or the pump has seized 3. The cable between the battery and the solenoid is disconnected or broken. 4. The solenoid has failed. 5. Power from the relay is disconnected. 	<ol style="list-style-type: none"> 1. Connect the cables. 2. Check for voltage at the pump motor while the ignition switch is on and the Raise button is pressed on the controller. If voltage is present, the motor brushes or pump/motor assembly may be replaced. 3. Check for power to the solenoid by testing for voltage between both large terminals and ground. If voltage is not present between one large terminal and ground, connect or replace the cable. 4. Check for voltage between the other large terminal of the solenoid and ground while jumping power to the small terminal with the white/black wire. If no voltage is present, replace the solenoid. If voltage is present, connect or replace the wire from the small terminal of the solenoid to ground. 5. Test the voltage between the black wire and ground at the white 9-pin connector. If no voltage is present, connect the relay. If voltage is present, check the wiring and controller switches.
The pump continues to run while the switch is in neutral.	<ol style="list-style-type: none"> 1. The solenoid has failed in the closed position. 2. There is a short between the black and white/black wire in the controller. 3. The switch has failed. 	<ol style="list-style-type: none"> 1. Disconnect the controller and turn the ignition on. If the pump continues to run, quickly remove power to the pump by disconnecting the power/ground cables to the plow and replace the solenoid. 2. Disconnect the controller and turn the ignition on. If the pump stops running, replace the wire. 3. Replace the switch.
The plow does not lower.	<ol style="list-style-type: none"> 1. The power/ground cables or control cables are not connected. 2. The flow-control valve is closed. 3. The wiring on the valve block is not connected. 4. The solenoid valve or valve coil has failed. 5. Power from the relays is disconnected. 	<ol style="list-style-type: none"> 1. Connect the cables if they are not connected. 2. Place the controller in neutral, then open the flow-control valve. 3. Refer to the wiring schematic. 4. Check for voltage between the solenoid valve terminal and ground while the ignition switch is on and the controller is in the Float position. If voltage is present, replace the valve or valve coil. 5. Check the voltage between the black wire and ground at the white 9-pin connector. If no voltage is present, connect the relays. If voltage is present, check the wiring and switch off the controller.
The plow lowers too fast.	<ol style="list-style-type: none"> 1. The flow-control valve is open too much. 	<ol style="list-style-type: none"> 1. Close the flow-control valve to the desired drop speed.

Problem	Possible Cause	Corrective Action
The plow does not raise or raises slowly.	<ol style="list-style-type: none"> 1. The hydraulic-fluid level is low. 2. The power/ground cables or the control cable are not connected. 3. The wiring on the valve block is not connected. 4. The battery is weak or needs replacing. 5. The motor brushes are bad. 6. The pump pressure relief valve is set to less than 172 bar (2,500 psi), contaminated, or damaged. 7. The pump is worn 8. The Raise control solenoid valve is not opening completely. 9. The Lower control solenoid valve is stuck open. 	<ol style="list-style-type: none"> 1. Check the hydraulic-fluid level; refer to the Checking the Hydraulic Fluid section. 2. Connect the cables. 3. Refer to the wiring schematic. 4. Load a test battery and replace it if necessary. 5. Check the motor brushes and replace them if necessary. 6. Ensure that the pressure is set to 172 bar (2,500 psi). Check the pressure again. If it is less than 172 bar (2,500 psi) at the end of the lift, clean or replace the pressure relief valve. 7. Replace the pump. 8. Replace the valve. 9. Replace the valve.
The plow angles while plowing.	<ol style="list-style-type: none"> 1. The ANGLE control solenoid valve is contaminated or damaged. 2. The pressure relief valve is contaminated or damaged. 3. The pressure relief valve is set incorrectly. 	<ol style="list-style-type: none"> 1. Clean or replace the ANGLE control solenoid valve. 2. Clean or replace the pressure relief valve. 3. Contact your authorized BOSS dealer.
The plow does not angle or angles slowly.	<ol style="list-style-type: none"> 1. The hydraulic-fluid level is incorrect. 2. The power/ground cables and/or the control cables are not connected properly. 3. The wiring connections on the valve block are not connected properly. 4. The battery is damaged or depleted. 5. The ANGLE control solenoid valve does not open completely. 	<ol style="list-style-type: none"> 1. Ensure that the hydraulic-fluid level should be within 2 cm (3/4 inch) of the top of the reservoir when the plow is lowered. 2. Connect the cables if they are not connected. 3. Refer to the manifold wiring schematic included with your <i>Owner's Manual</i>. 4. Load a test battery and replace it if necessary. 5. Replace the ANGLE control solenoid valve.
Fluid leaks from the lift cylinders.	<ol style="list-style-type: none"> 1. The fittings are loose or the O-rings are damaged. 2. The rods are pitted or rough. 	<ol style="list-style-type: none"> 1. Tighten loose fittings. See your authorized BOSS dealer for a seal kit. 2. Polish them with a copus cloth or extra fine steel wool.
The vehicle battery dies when the vehicle is turned off.	<ol style="list-style-type: none"> 1. The wire harness isn't connected to a keyed fuse source. 	<ol style="list-style-type: none"> 1. Connect the wire harness to a keyed fuse source; refer to the wire schematic.
The vehicle battery dies when all of the switches are in the Neutral position.	<ol style="list-style-type: none"> 1. There is a short in the controller wiring. 2. There is a short in the wire harness. 3. There is a short in the valve coils. 	<ol style="list-style-type: none"> 1. Repair or replace the controller. 2. Repair or replace the wire harness. 3. Replace the valve coils.

Problem	Possible Cause	Corrective Action
The plow lights are dim, do not come on, or flicker.	<ol style="list-style-type: none"> 1. The electrical connections are corroded or damaged.. 2. The wrong headlight adapters are being used. 3. The headlight adapters are not installed correctly. 4. The relays are corroded or broken. 	<ol style="list-style-type: none"> 1. Clean and repair the terminals. 2. Replace the headlight adapters with the correct ones. 3. Correctly install the headlight adapters. 4. Clean or replace the relays.
The turn signals flash at a rapid rate.	<ol style="list-style-type: none"> 1. The wrong headlight adapters are being used. 2. The headlight adapters are not installed correctly. 3. The wrong flasher is being used. 	<ol style="list-style-type: none"> 1. Replace the headlight adapters with the correct ones. 2. Correctly install the headlight adapters. 3. Replace the vehicle flasher with a heavy-duty 6 A flasher.
There is no high-beam indicator light, or it does not function properly.	<ol style="list-style-type: none"> 1. The wrong headlight adapters are being used. 2. The headlight adapters are not installed correctly. 	<ol style="list-style-type: none"> 1. Replace the headlight adapters with the correct ones. 2. Correctly install the headlight adapters.
The blade trips too easily.	<ol style="list-style-type: none"> 1. The trip springs are loose or damaged. 2. The pushbeam is not at the correct height. 	<ol style="list-style-type: none"> 1. Tighten the springs or replace them if they are damaged. 2. Adjust the push beam to the proper height.
The plow does not clean up snow from low areas.	<ol style="list-style-type: none"> 1. The controller is not in the FLOAT position. 	<ol style="list-style-type: none"> 1. Activate the FLOAT feature on the controller.
Fluid is running out of the fill cap of the hydraulic pump.	<ol style="list-style-type: none"> 1. The terrain is too steep. 2. The pump reservoir is overfilled. 3. The plow is hitting snowbanks too hard. 	<ol style="list-style-type: none"> 1. Avoid steeply sloped areas. 2. The hydraulic fluid level should be within 2 cm (3/4 inch) of the top of the reservoir. 3. Do not plow recklessly.
The pump chatters when raising or angling the plow.	<ol style="list-style-type: none"> 1. The hydraulic-fluid level is low. 	<ol style="list-style-type: none"> 1. Check the hydraulic-fluid level; refer to the Checking the Hydraulic Fluid section.
The SmartHitch2 does not attach to the plow.	<ol style="list-style-type: none"> 1. The controller is not in the FLOAT position. 2. The controller is malfunctioning. 3. The valve block and SmartHitch2 switch are not properly connected. 	<ol style="list-style-type: none"> 1. Turn the vehicle on and put the controller in the FLOAT position. 2. Replace the controller. 3. Check valve block and the SmartHitch2 switch for proper connections; refer to the manifold wiring diagram included with your <i>Owner's Manual</i>.
The plow lights and truck lights are on at the same time.	<ol style="list-style-type: none"> 1. The vehicle wire harness is plugged into the vehicle headlight. 	<ol style="list-style-type: none"> 1. Check the wiring connections; refer to the wiring diagram included with your <i>Owner's Manual</i>.
All of the plow and vehicle lights are on at the same time.	<ol style="list-style-type: none"> 1. The headlight adapters are not installed correctly. 	<ol style="list-style-type: none"> 1. Correctly install the headlight adapters.

Problem	Possible Cause	Corrective Action
The plow wings do not extend or retract.	<ol style="list-style-type: none"> 1. If the status light on the plow module is green but not blinking, the controller is not communicating correctly. 2. If the status light on the plow module is orange, the plow module may be wired incorrectly. 3. If the status light on the plow module is blinking orange or red, there is a problem with the module driver. 4. If the status light on the plow module is off, the plow module is not getting power. 	<ol style="list-style-type: none"> 1. Check the controller connections. Replace the controller if it is broken. 2. Refer to the wiring diagram included with your <i>Owner's Manual</i>. 3. Check the module connections for shorts. Replace the module if it is broken. 4. Check that the controller is on and that all of the plugs are connected.

Schematics

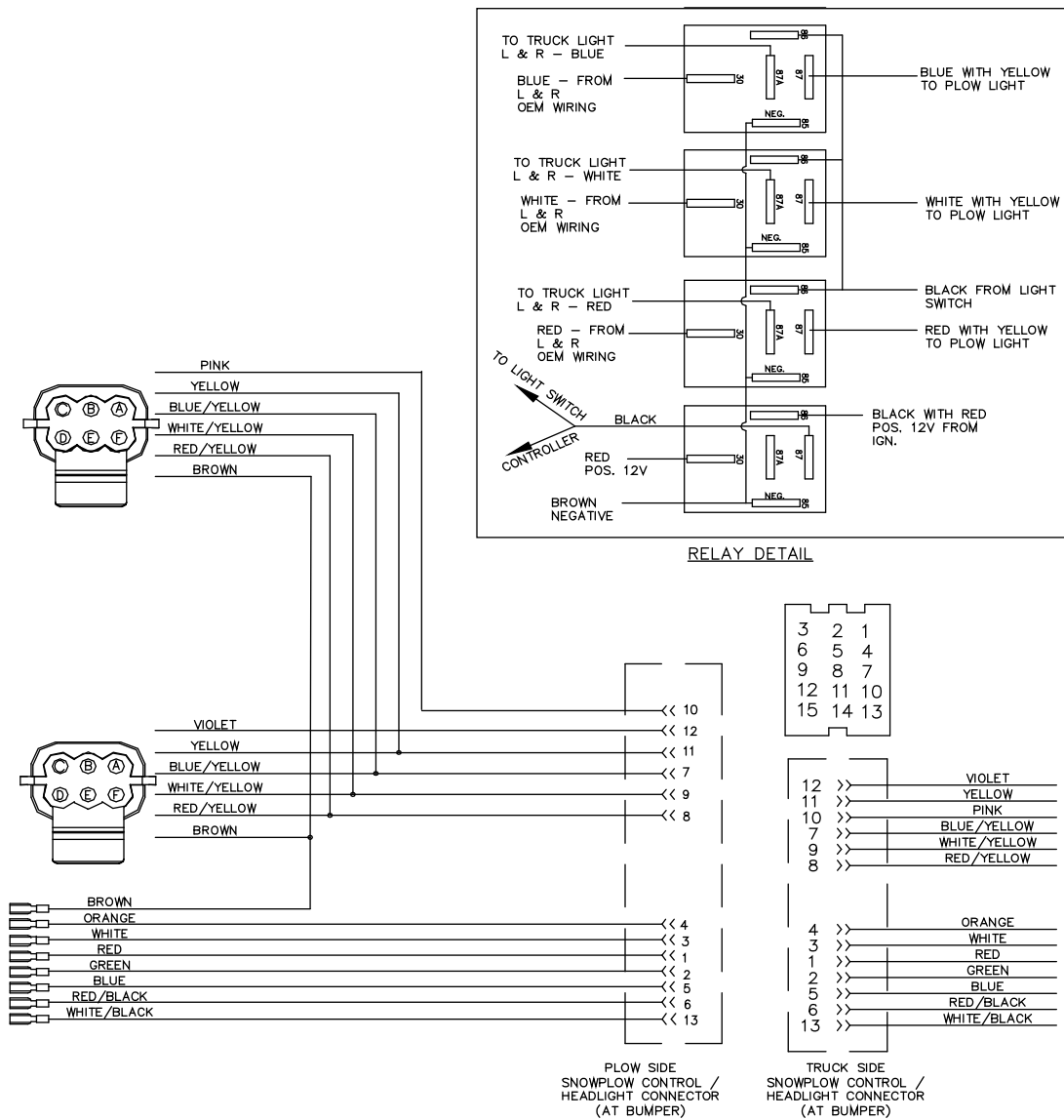

Plow Side Electrical Schematic (Rev. 0)

g272184

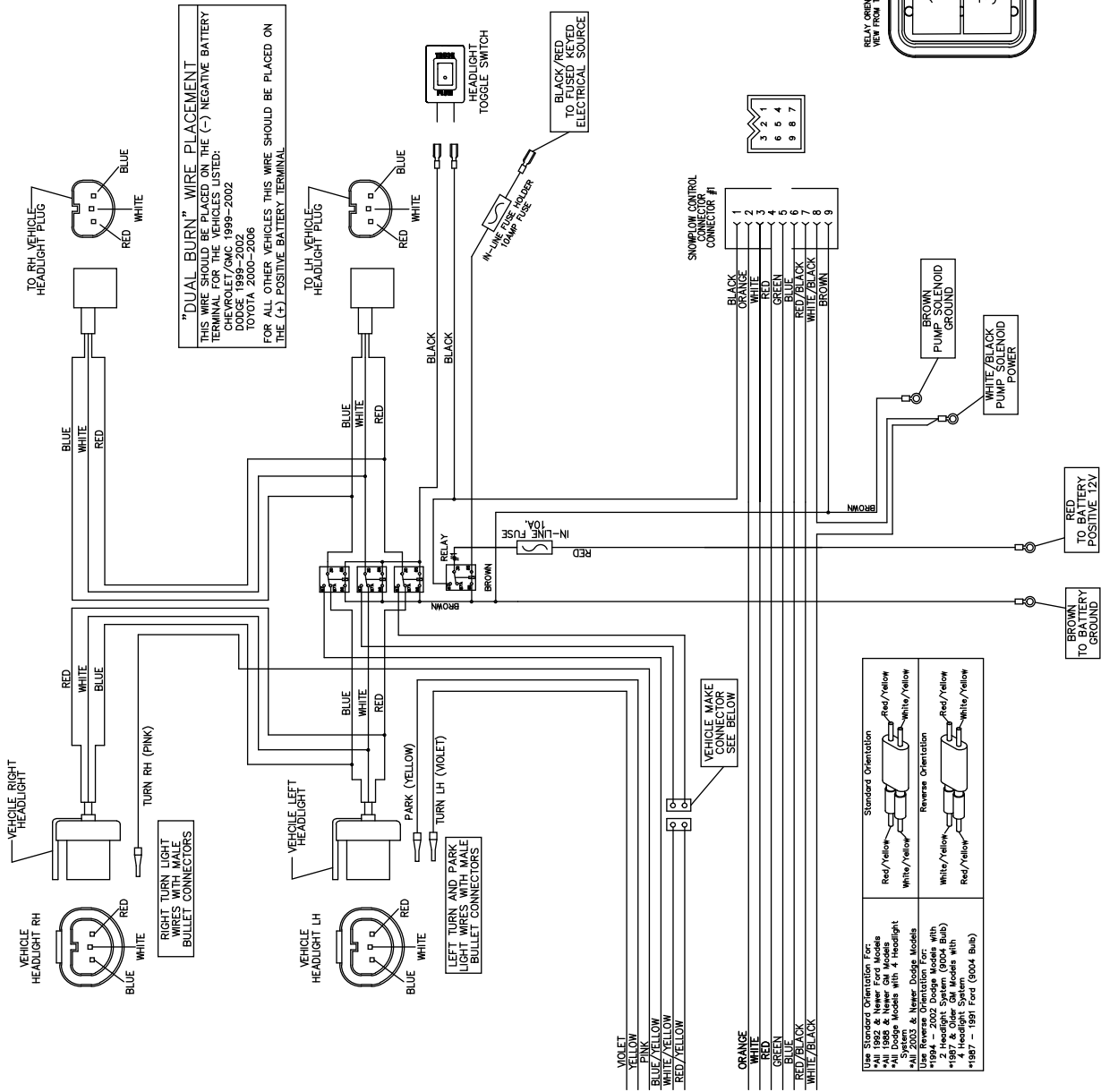

Truck Side Electrical Schematic (Rev. 0)

g272185

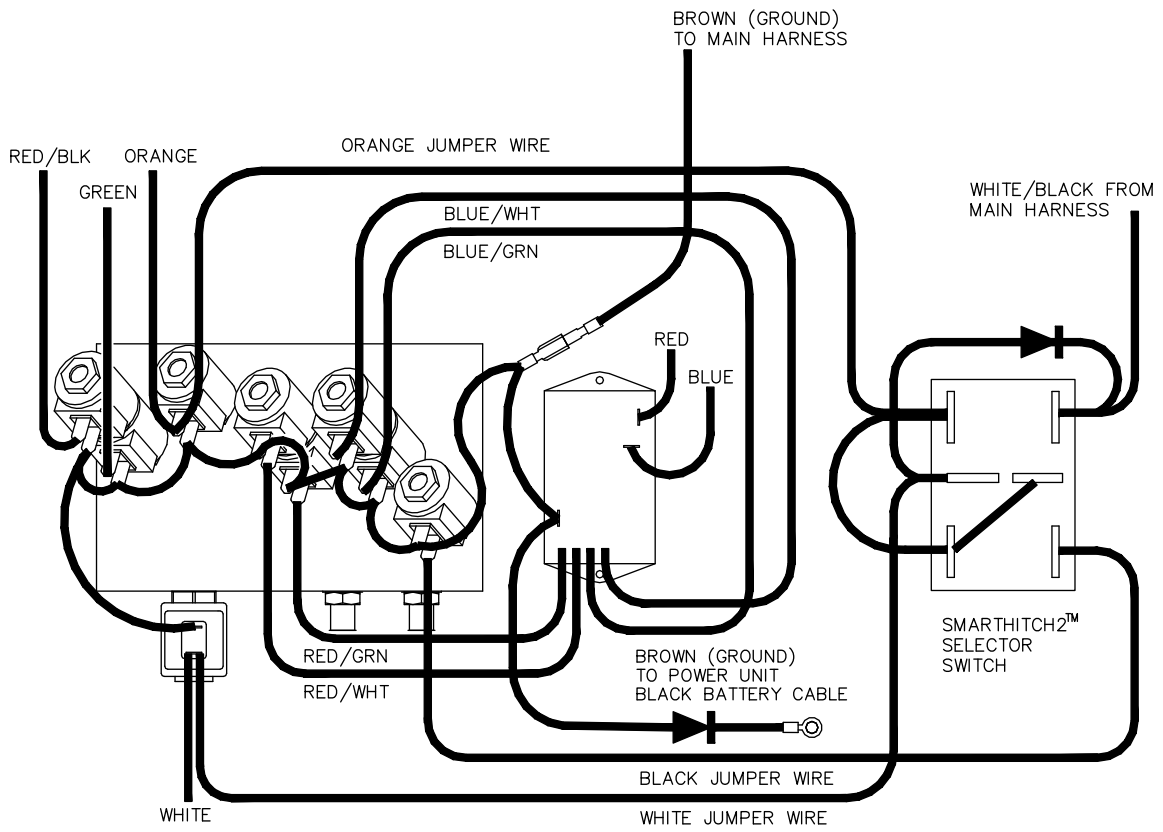

G038108

g038108

Wire Color	Function
Green	Blade Left
Red/Black	Blade Right
White	Lift
Orange	Lower
Red	Communication
Blue	Module Power
Black	SmartHitch2
Brown	Ground
Red/Green	Right wing retract
Red/White	Right wing extend
Blue/Green	Left wing retract
Blue/White	Left wing extend

Hydraulic Diagram (Rev. 0)

Notes:

Notes:

BOSS

S N O W P L O W