

### Installation Instructions

1. Secure the inner mounting plate to the inside of the spreader hopper using 4 long bolts for your spreader below and 3 lag bolts.

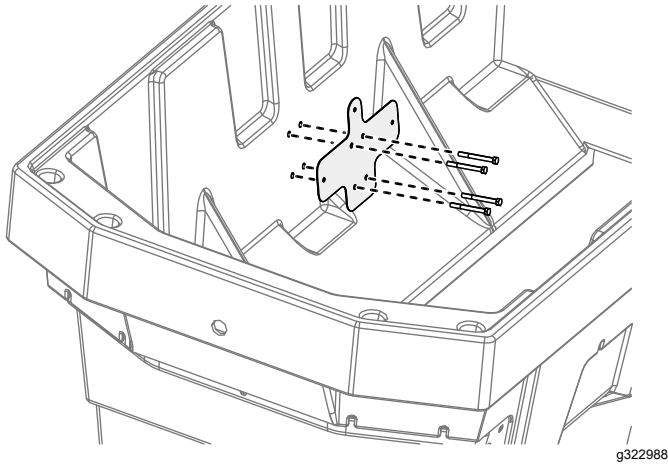

Figure 1

g322988

2. Place the front bracket onto the bolts.

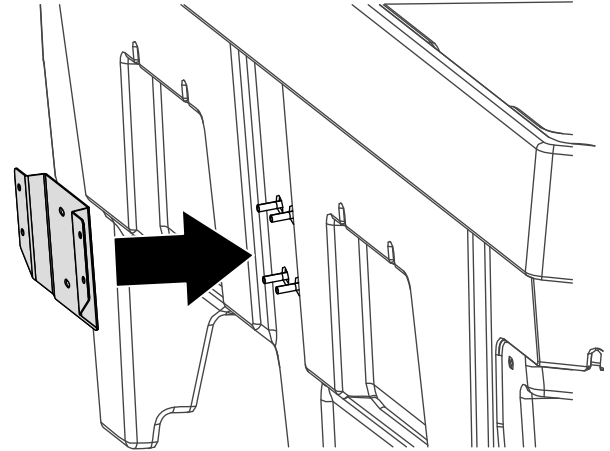

Figure 3

g322990

3. Slide the vibrator on to the 4 bolts and secure with 4 locknuts.

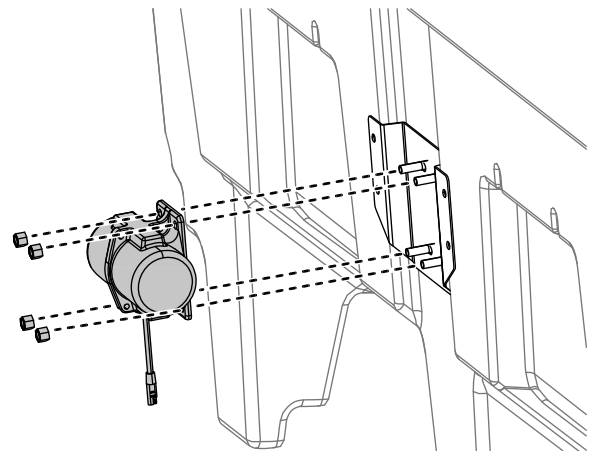
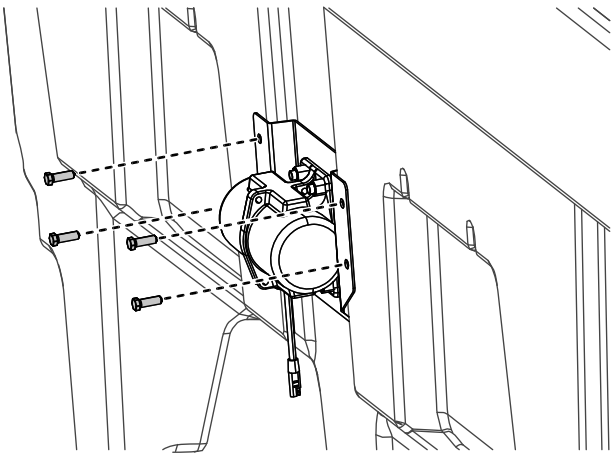

Figure 4

g322991

- Secure the outer mounting plate to the hopper using 4 lag bolts.



g322992

**Figure 5**

- Torque the 4 bolts securing the vibrator to 26 N·m (19 ft-lb).
- Connect the vibrator connector to the spreader wire harness.
- Repeat the installation on the other side of the spreader.

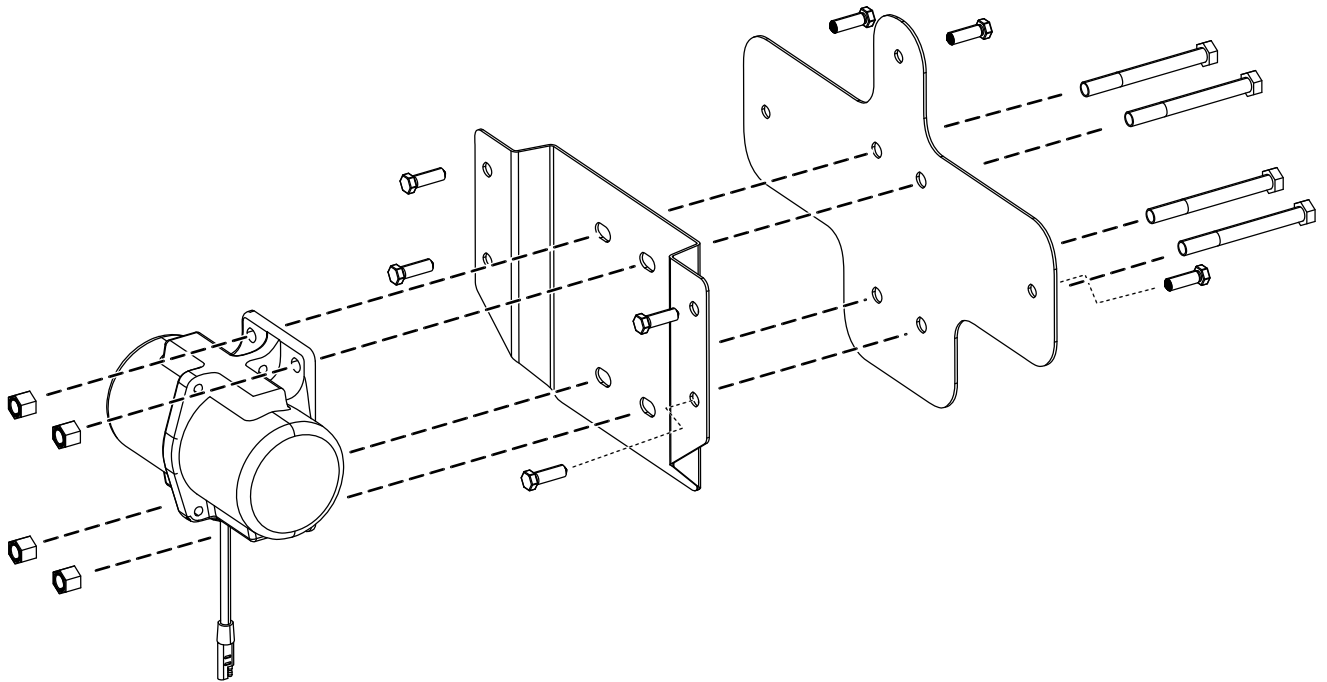

g322993

**Figure 6**