

BOSS PRODUCTS  
A Division of Northern Star Industries, Inc.  
P.O. Box 787 Iron Mountain MI 49801-0787  
[www.bosspow.com](http://www.bosspow.com)

**1999 - 2002 CHEVROLET/GMC  
1/2 TON RT3 UNDERCARRIAGE  
MOUNTING INSTRUCTIONS  
(PART NO. LTA03698)**

## **WARNING**

Many newer trucks are now equipped with air bags. DO NOT under any circumstances disable, remove or relocate any sensors or other components related to the operation of the air bags.

Always follow the vehicle manufacturers' recommendations relating to snowplow installation. For recommended vehicle models refer to the BOSS Snowplow Application Chart and Selection Guide.

To comply with Federal Regulations and to assure a safe vehicle, the Front Gross Axle Weight Rating (FGAWR), Rear Gross Axle Weight Rating (RGAWR), and the Gross Vehicle Weight Rating (GAWR) must not be exceeded at any time.

Due to the variety of equipment that can be installed on this vehicle, it is necessary to verify that the Front Gross Axle Weight Rating (FGAWR), Rear Gross Axle Weight Rating (RGAWR), and the Gross Vehicle Weight Rating (GAWR) are not exceeded at any time. This may require weighing the vehicle and adding ballast as necessary. It may also limit payload capacity of the vehicle. It is the operator's responsibility to verify that these ratings are not exceeded.

## **1999 & NEWER CHEVROLET/GMC ½ TON RT3 UNDERCARRIAGE MOUNTING INSTRUCTIONS**

The mounting procedure outlined below covers CHEVROLET/GMC (1999 and Newer) ½ ton 4 X 4 trucks. You will need to refer to the illustrations and familiarize yourself with each of the undercarriage components and their relative position to each other. Then proceed as follows:

1. Remove the existing tow hook bolts. Note: it may be necessary to remove the front bumper to remove the tow hooks. Position the PUSH BEAM SUPPORT PLATES (Ref. 62A and B, Fig. 1) to the front frame rails of the truck. Use the ½" – 13 x 6 bolts, the ½" – 13 hex head self locking nuts, the M12 x 40mm hex head bolts and the M12 lock washers to bolt the PUSH BEAM SUPPORT PLATES in place (see Fig. 1). Drill the frame rail for the rear bolt position on the PUSH BEAM SUPPORT PLATES. Lower the PUSH BEAM SUPPORT PLATES and insert the J-NUTS. Replace the PUSH BEAM SUPPORT PLATES and secure using the hardware already mentioned and the 3/8-16 x 1-1/4 bolts. Fasteners should only be finger tight.
2. Remove the existing plastic engine guard from the bottom front of the vehicle. Remove the four existing bolts holding the skid plate in place on the vehicle. Drill out the rear two existing positions in the vehicle crossmember as shown in Fig, 1, the bottom of the plastic engine guard and the front of the skid plate to 9/16". Using the ½" – 13 x 1- ½" bolts and ½" – 13 hex head self locking nuts mount the ANGLE BRACKET (Ref. 75, Fig. 1) into place under the plastic engine guard and the skid plate. The plastic engine guard will need to be slotted for the ANGLE BRACKET. Bolts should only be finger tight. The plastic engine guard will be re-attached to the crossmember in step 5. Re-install the bumper if removed in step 1.

3. Bolt the PUSH BEAM (Ref. 62, Fig. 1) in place using the  $\frac{1}{2}$ " – 13 x 1-  $\frac{1}{2}$ " hex head bolts and self locking nuts provided. Fasteners should only be finger tight. Use the  $\frac{1}{2}$ " – 13 x 1-  $\frac{1}{2}$ " grade 8 bolts and  $\frac{1}{2}$ " – 13 grade 8 hex head self locking nuts to attach the ANGLE BRACKET to the PUSHBEAM with at least 2 bolts on each leg. The grade 8 hardware is coated with yellow zinc to distinguish them from other fasteners. NOTE: the proper height adjustment for the PUSH BEAM is approximately 15- $\frac{1}{2}$ " from the ground to the center of the PUSH BEAM pin-receiving hole (See Figure 2). It may be necessary to cut two small slots in the bottom of the plastic air dam to provide relief for the pushbeam support plates and the pushbeam.
4. Align the lower holes of the plastic splash shield with the corresponding holes in the cross member and attach using the original hardware.
5. With all undercarriage parts in place, securely fasten all mounting hardware. It is important that all fasteners be properly torqued (see Fig. 3) to assure a safe operating plow. Retighten all fasteners after 2 hours of plowing.

## 1999 & NEWER CHEVROLET/GMC 1/2 TON RT3 UNDERCARRIAGE INSTALLATION PROCEDURE

REF. NO.	DESCRIPTION	PART NO.	QTY.
62	Push Beam Assembly	PBA07909	1
62A	Push Beam Support Plate (RH)	PBA04145	1
62B	Push Beam Support Plate (LH)	PBA04146	1
75	Angle Bracket	LTA04150	1
	FASTENER KIT, CHEVY 1/2 TON 99	HDW05581	1
Includes:			
A	1/2" – 13 x 1- 1/2" Hex Head Bolt	HDW01728	12
B	1/2" – 13 x 6" Hex Head Bolt	HDW05526	2
C	1/2" – 13 Hex Head Self Locking Nut	HDW01748	14
D	M12 x 1.75 x 40 MM Hex Head Bolt	HDW05584	2
E	M12 Lock Washer	HDW05585	2
F	3/8-16 J-NUT	HDW05578	2
G	3/8-16 x 1-1/4" Hex Head Bolt	HDW01771	2
H	3/8" Flat Washer	HDW01733	2
I	3/8" Split Lock Washer	HDW01718	2
J	1/2" – 13 x 1- 1/2" Hex Head Bolt Grade 8	HDW05553	4
K	1/2" – 13 Hex Head Self Locking Nut Grade 8	HDW05554	4

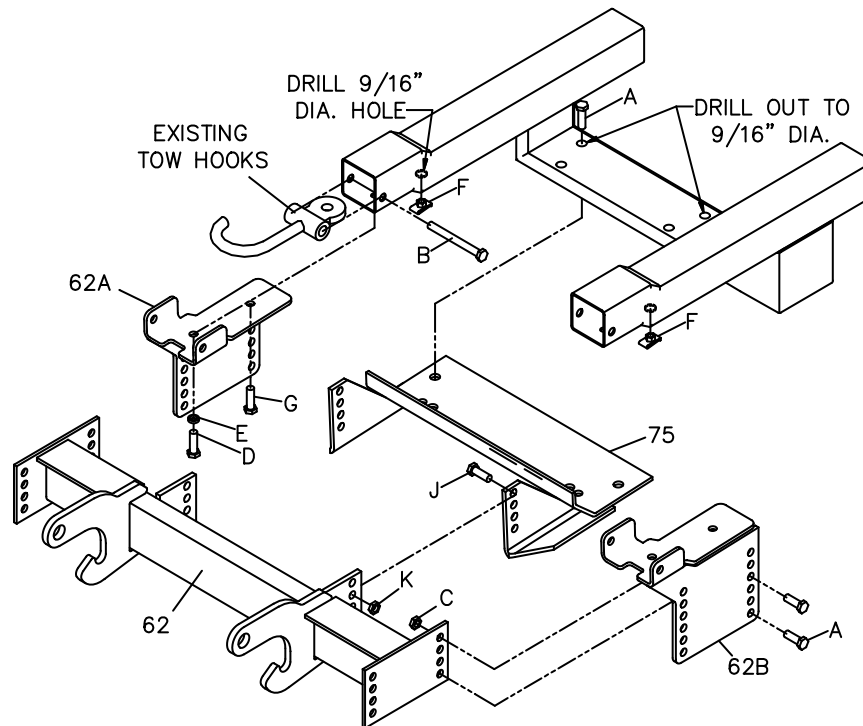
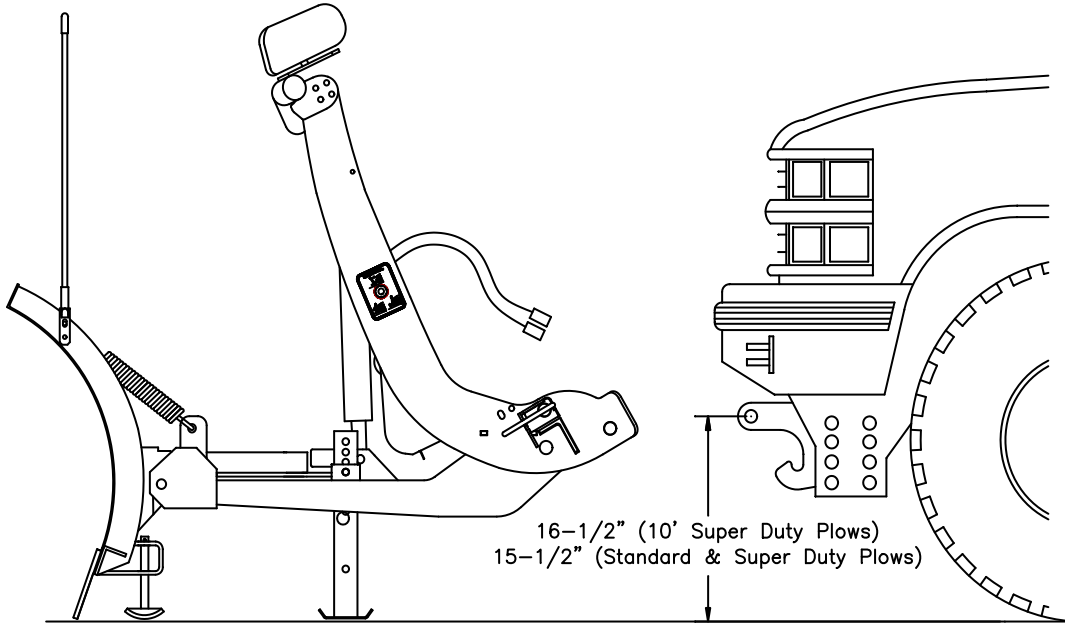

Figure 1

G10430

## RECOMMENDED PUSHBEAM HEIGHT



**Figure 2**

G10155

## GUIDE TO RECOMMENDED ASSEMBLY TORQUE



DIAMETER / PITCH	GRADE 5	GRADE 8	GRADE 8.8	GRADE 10.9
1/4-20	6	9		
5/16-18	14	19		
3/8-16	23	33		
7/16-14	38	53		
1/2-13	56	80		
9/16-12	82	116		
5/8-11	113	159		
3/4-10	201	283		
M10 X 1.25			36	
M10 X 1.5				49
M12 X 1.75				71
M14 X 2.0				80

ALL TORQUE VALUES ARE IN FOOT-POUNDS (FT.-LB.)

**Figure 3**

G10410

\* The torque values listed above are based on dry, coated bolts, variables such as oil, or other lubrications may appreciably alter these values and must be taken into consideration.

**NOTE:** IT IS IMPORTANT THAT ALL FASTENERS BE PROPERLY TORQUED TO ASSURE A SAFE OPERATING PLOW. RE-TIGHTEN ALL FASTENERS AFTER 2 HOURS OF PLOWING.