

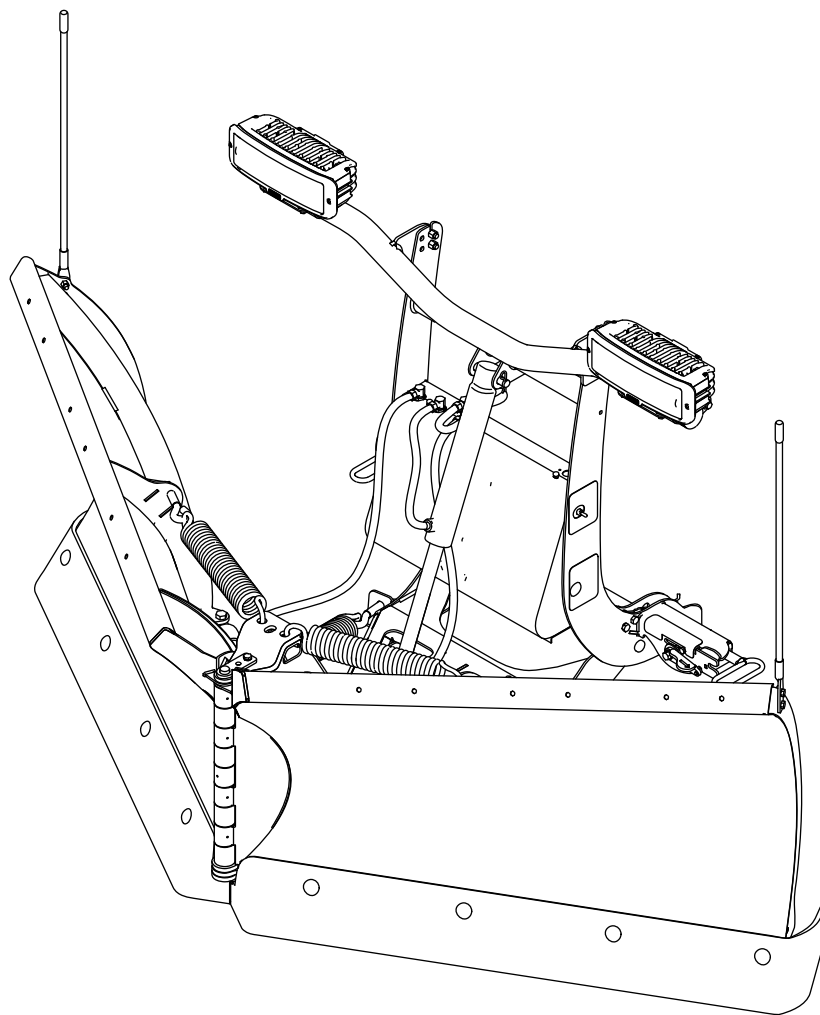

P.O. Box 787
Iron Mountain, MI 49801
United States

Installation Instructions

RT3 HTX V-Blade Plow



G038296



This product complies with all relevant European directives; for details, please see the separate product specific Declaration of Conformity (DOC) sheet.

BOSS Products limited consumer warranty and BOSS Products commercial warranty policies are located at www.BOSSPlow.com.

Patents pending.

Introduction

Note: Use this manual to assemble and install all BOSS HTX V-blade plows. Illustrations may vary.

Read this information carefully to learn how to operate and maintain your product properly and to avoid injury and product damage. You are responsible for operating the product properly and safely.

Visit www.BOSSPlow.com for product safety and operation training materials, accessory information, help finding a dealer, or to register your product.

Whenever you need service, genuine BOSS parts, or additional information, contact an Authorized BOSS Dealer or BOSS Technical Service (1-800-286-4155) and have the model and serial numbers of your product ready. **Figure 1** identifies the location of the model and serial numbers on the product. Write the numbers in the space provided.

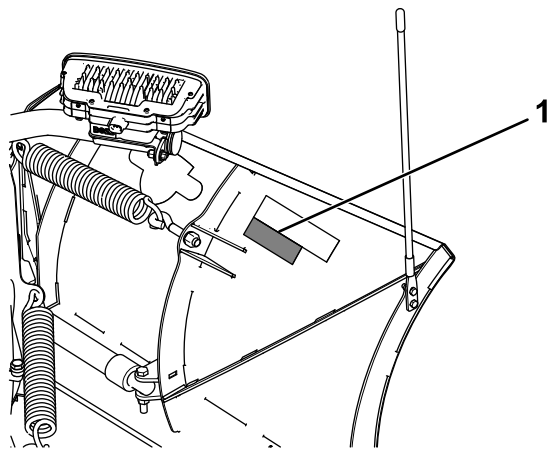

Figure 1

g270731

1. Model and serial number location

Date Purchased	_____
Model No.	_____
Serial No.	_____
Blade Crate Serial No.	_____

This manual identifies potential hazards and has safety messages identified by the safety-alert symbol (**Figure 2**), which signals a hazard that may cause serious injury or death if you do not follow the recommended precautions.



Figure 2

Safety-alert symbol

g000502

This manual uses 2 words to highlight information. **Important** calls attention to special mechanical information and **Note** emphasizes general information worthy of special attention.

Contents

Safety	3
Preparation.....	3
Operation.....	3
Safety and Instructional Decals	4
Installation	7
Installing the Push Frame and Angle Cylinders.....	7
Installing the Trip Springs and Coupler Tower	8
Installing the Hydraulic Hoses.....	9
Installing the Light Bar	9
Installing the Blade Guides and Filling the Hydraulic Reservoir.....	10
Installing the Wire Harness	11
Installing the Headlight Adapters	15
Mounting the Plow Controller	16
Mounting the Snowplow.....	17
Adjusting the Pushbeam Height.....	17
Leveling the Plow Blades	18
Aiming the Headlights.....	18
Product Overview	20
Controls	20
Specifications	22
Troubleshooting	23
Schematics	27

Safety

Improper use or maintenance by the operator or owner can result in injury. To reduce the potential for injury, comply with these safety instructions and always pay attention to the safety-alert symbol , which means **Caution, Warning, or Danger**—personal safety instruction. Failure to comply with the instruction may result in personal injury or death.

Preparation

- Read the *Owner's Manual* before operating or servicing the plow.
- Always follow the vehicle manufacturer's recommendations relating to snowplow installation. For recommended vehicle models, refer to the BOSS product selector tool at www.BOSSPlow.com.
- Ensure that only trained personnel install and perform maintenance on the equipment and hydraulic components.
- Never disable, remove, or relocate any sensors or other components related to the operation of the air bags in your vehicle.
- Keep your hands, feet, and clothing away from moving parts and mounting points.
- Ensure the plow is properly attached to the vehicle before moving it.
- To comply with federal regulations and to assure a safe vehicle, do not exceed the front gross-axle-weight rating (FGAWR), rear gross-axle-weight rating (RGAWR), and the gross-vehicle-weight rating (GVWR) at any time.
- Always wear appropriate personal protective equipment when operating and servicing the machine. Wear substantial, slip-resistant footwear, and cold-weather clothing.
- Use a 500 kg (1/2 ton) minimum lifting device to move heavy plow components.
- Material safety data sheets (MSDS) are available at www.BOSSPlow.com.
- When transporting the vehicle, position the plow so as not to block your vision or the plow headlights.
- Do not change the blade position when traveling.
- Do not exceed 64 km/h (40 mph) when transporting the plow.
- Do not exceed 22 km/h (14 mph) when plowing.
- Always lower the blade when the vehicle is not in use.
- Never put any part of your body between the plow and the vehicle.
- Do not operate the machine while ill, tired, or under the influence of alcohol or drugs.
- Use your full attention while operating the machine. Do not engage in any activity that causes distractions; otherwise, injury or property damage may occur.
- Always wear your seat belt while operating a motor vehicle.
- Due to the variety of equipment that you can install on the vehicle, do not exceed the front gross-axle-weight rating (FGAWR), rear gross-axle-weight rating (RGAWR), and the gross-vehicle-weight rating (GVWR) at any time. This may require weighing the vehicle and adding ballast as necessary. It may also limit the payload capacity of the vehicle.
- This machine has an operating sound level below 70 dBA.
- When transporting the machine, ensure that it is properly secured. Instructions are available at www.BOSSPlow.com.

Operation

- Vehicles equipped with air bags are designed so that the air bags activate in a frontal collision equivalent to hitting a solid barrier (such as a wall) at approximately 22 km/h (14 mph) or more, or a frontal perpendicular collision with a parked car or truck of similar size at approximately 45 km/h (28 mph) or more. Careless or high-speed driving while plowing snow can deploy the air bag.

Safety and Instructional Decals



Safety decals and instructions are easily visible to the operator and are located near any area of potential danger. Replace any decal that is damaged or missing.

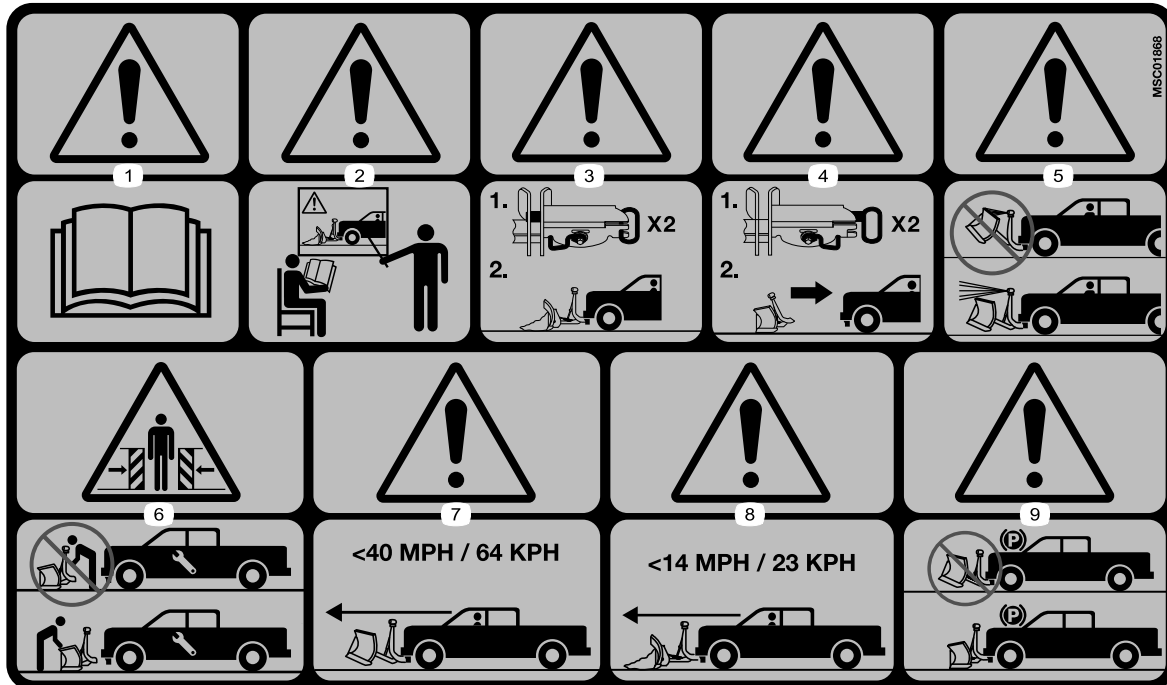

decalsc01868

MSC01868

1. Warning—read the *Owner's Manual*.
2. Warning—all operators should be trained before operating the machine.
3. Warning—coupler spring pins must be locked before plowing.
4. Warning—coupler spring pins must be unlocked to remove the plow.
5. Warning—do not block the vehicle headlights with the plow.
6. Crushing hazard—do not stand between the plow and vehicle during maintenance.
7. Warning—do not exceed 64 km/h (40 mph) when transporting the plow.
8. Warning—do not exceed 22 km/h (14 mph) when plowing.
9. Warning—lower the plow when the vehicle is not in use.

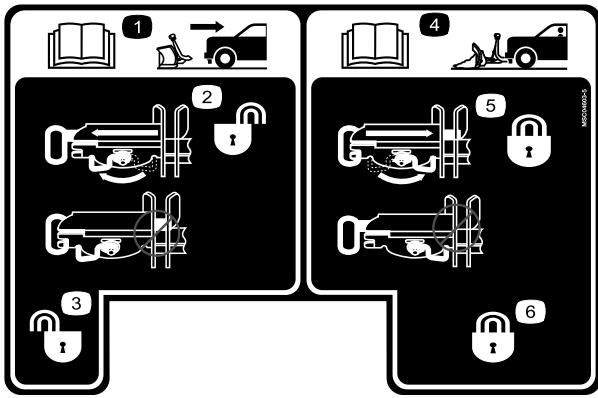

MSC04603-5

decalsmc04603-5

1. Read the *Owner's Manual* for information on removing the plow.
2. Coupler spring pin unlock
3. Coupler spring pin unlock
4. Read the *Owner's Manual* for information on attaching the plow.
5. Coupler spring pin lock
6. Coupler spring pin lock

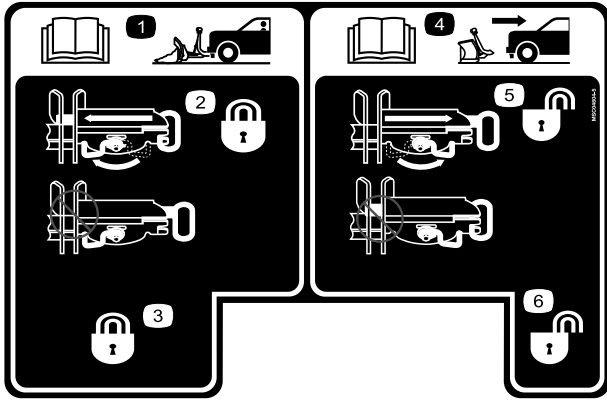

MSC04604-5

decalsmc04604-5

1. Read the *Owner's Manual* for information on attaching the plow.
2. Coupler spring pin lock
3. Coupler spring pin lock
4. Read the *Owner's Manual* for information on removing the plow.
5. Coupler spring pin unlock
6. Coupler spring pin unlock

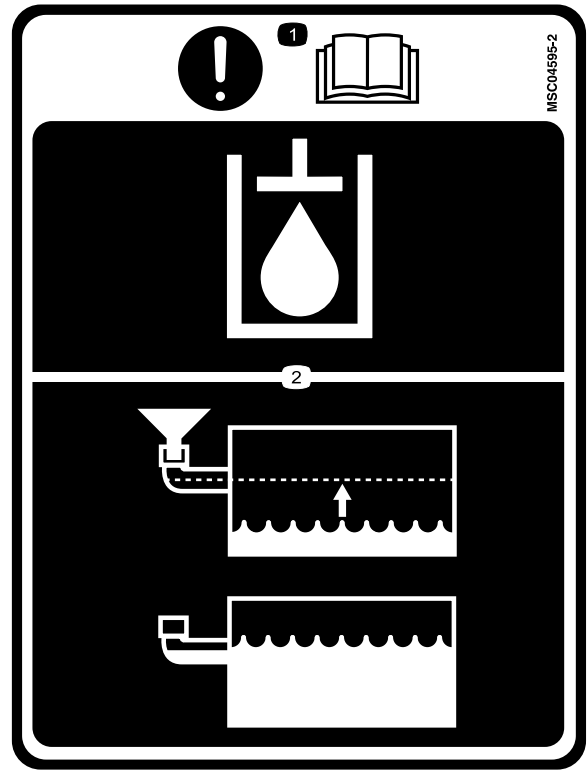

MSC04595

decalsmc04595

1. Important—read the *Owner's Manual*.
2. Fill the hydraulic fluid to the bottom of the fill elbow.

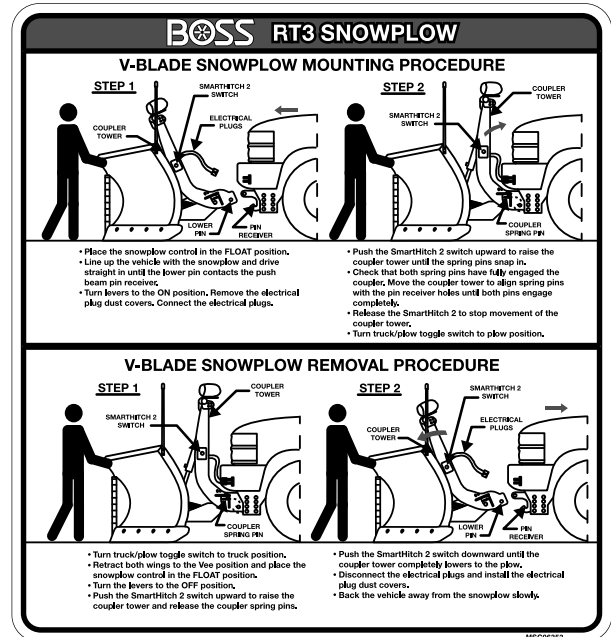

MSC06353

decalsmc06353

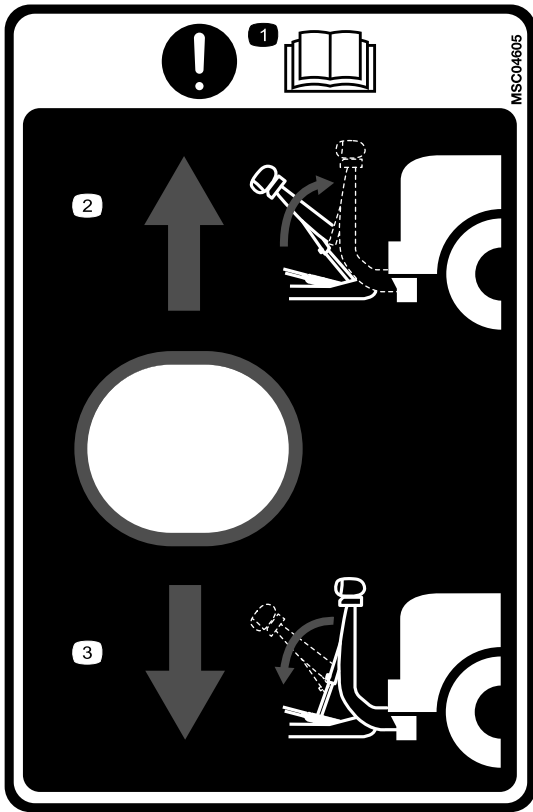

MSC04605

decalmsc04605

1. Important—read the *Owner's Manual*.
 2. Raise the coupler tower.
 3. Lower the coupler tower.
-

Installation

Determine the left and right sides of the machine from the normal operating position.

Installing the Push Frame and Angle Cylinders

If desired, install optional plow shoes before starting this installation.

1. Lay the left and right blades face down and bring them together so that the hinges interlock and the cutting edges are even (Figure 3).

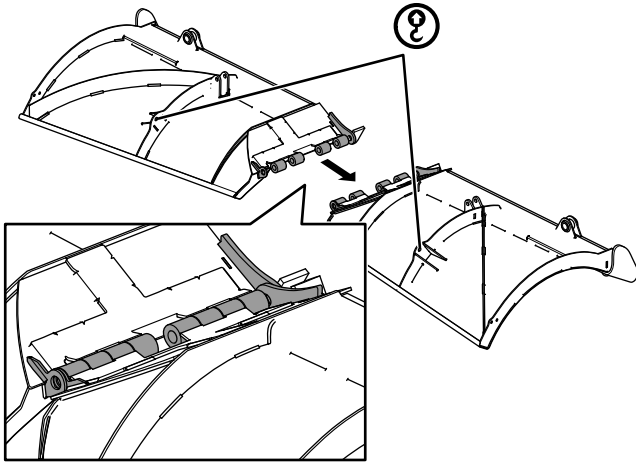

Figure 3

2. Insert the push-frame assembly between the blade hinges and secure all 3 pieces together with the center hinge pin, split lock washer (3/8 inch), and bolt (3/8 x 1-1/2 inches) with nylon lock patch (Figure 4).

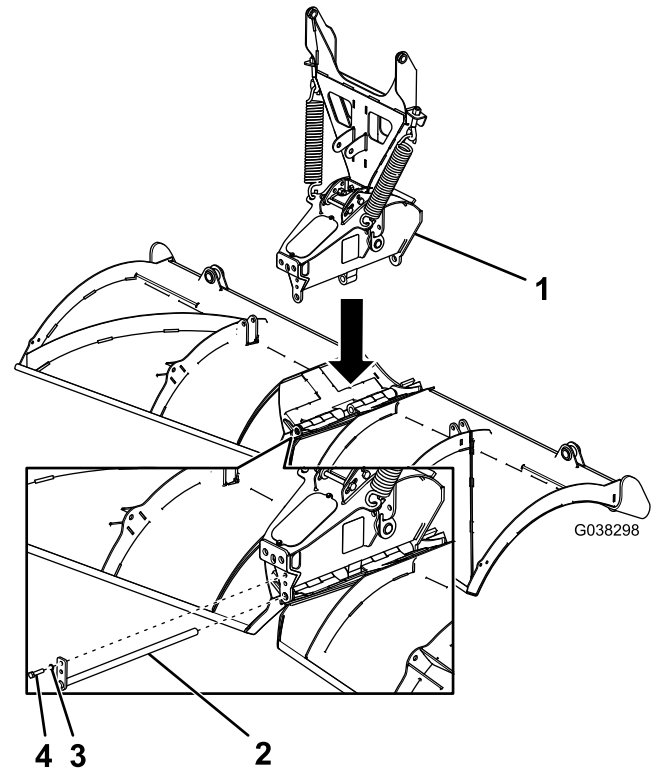

Figure 4

- | | |
|------------------------|---------------------------------|
| 1. Push-frame assembly | 3. Split lock washer (3/8 inch) |
| 2. Center hinge pin | 4. Bolt (3/8 x 1-1/2 inches) |

3. Stand the blade upright and position the sides into a "V" shape.
4. Attach the body end of the angle cylinders to the push-frame assembly using 2 hex-head bolts (3-1/2 inches) and top locknuts (Figure 5).

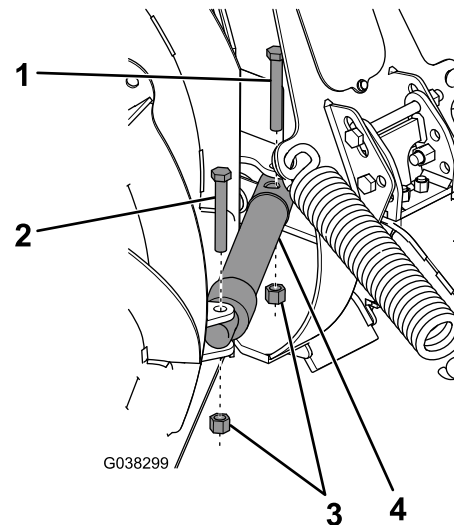

Figure 5

- | | |
|---------------------------------|-------------------|
| 1. Hex-head bolt (3-1/2 inches) | 3. Top locknuts |
| 2. Hex-head bolt (3 inches) | 4. Angle cylinder |

- Attach the rod end of the angle cylinders to the blades using 2 hex-head bolts (3 inches) and 2 top locknuts (Figure 5).

Installing the Trip Springs and Coupler Tower

- Hook the 2 trip springs through the holes on the top of the push-frame assembly (Figure 6).

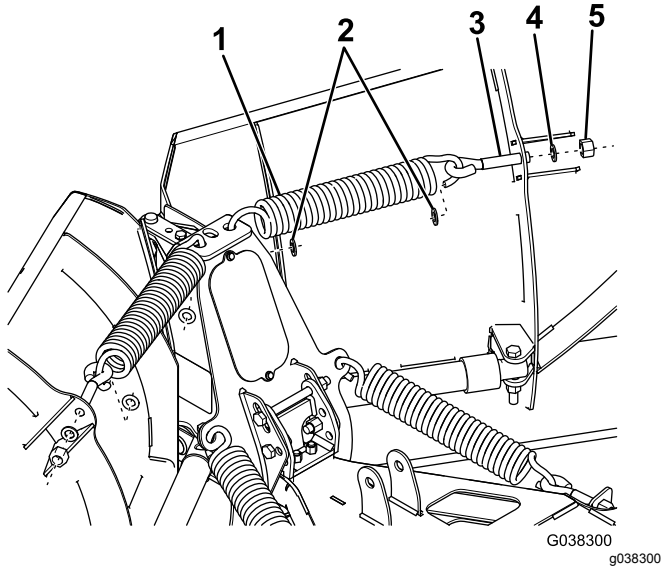

Figure 6

- Trip spring
- Push nut retainers
- Eyebolt
- Washer (1/2 inch)
- Self-locking nut (1/2 inch)

- Hook the other ends of the trip springs to 2 eyebolts (Figure 6).
- Insert the threaded end of the eyebolts through the holes on the plow blade and secure them using 2 washers (1/2 inch) and 2 self-locking nuts (Figure 6).
- Tighten the self-locking nuts until there is a gap of 0.8 mm (1/32 inch) between the trip spring coils.
- Slide a push nut retainer onto each end of the trip springs (Figure 6).
- Align the pivot holes of the coupler tower with the pivot holes on the push-frame assembly, and secure them as shown in Figure 7.

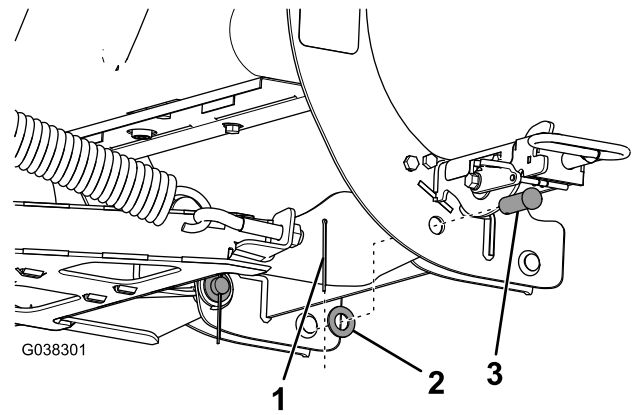

Figure 7

- Catter pin
- Flat washer (3/4 inch)
- Pivot pin

- Secure the rod end of the lift cylinder to the push-frame assembly using a clevis pin (5/8 inch) and hairpin catter (Figure 8).

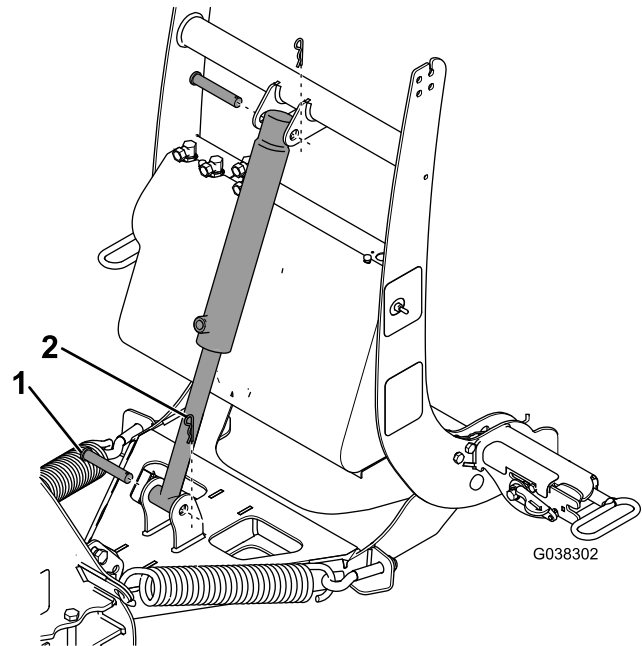

Figure 8

- Hairpin catter
- Clevis pin (5/8 inch)

- Secure the free end of the lift cylinder to the coupler tower using a clevis pin and hairpin catter (Figure 8).

Installing the Hydraulic Hoses

1. Install a swivel fitting to the lower port on the lift cylinder (Figure 9).
2. Install the 45 cm (18 inch) hydraulic hose to the middle fitting on the hydraulic shelf and the lower fitting on the lift cylinder (Figure 9). Turn the fitting until it is finger tight, then turn it 2 to 3 more times.

Important: Do not overtighten.

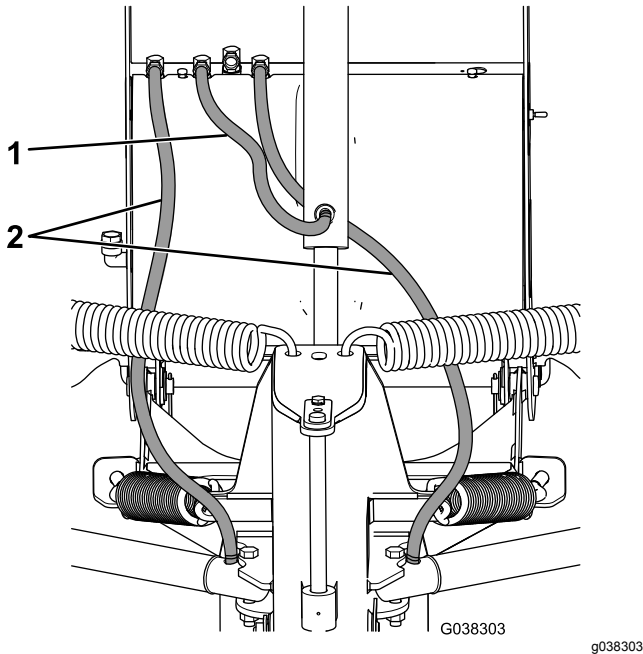

Figure 9

1. 45 cm (18 inch) hose
2. 106 cm (42 inch) hoses

3. Apply thread-locking compound to the threads on the O-ring end of the 106 cm (42 inch) hydraulic hoses.

Important: Do not get thread-locking compound on the end of the hose as it will contaminate the hydraulic system.

4. Install the O-ring end of the 106 cm (42 inch) hydraulic hose to the port on the right angle cylinder and the other end to the right fitting on the hydraulic shelf (Figure 9). Turn the fitting until it is finger tight, then turn it 2 to 3 more times.

Important: Do not overtighten.

5. Repeat step 4 on the left side.
6. Remove the plug on the upper fitting on the lift cylinder (Figure 10).

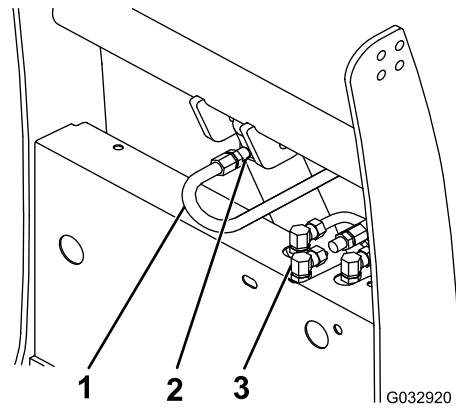

Figure 10

1. 39 cm (15-1/2 inch) hose
2. Upper lift-cylinder fitting
3. Rear fitting

7. Apply thread-locking compound to the threads on 1 end of the 39 cm (15-1/2 inch) hydraulic hose.
8. Install that end of the hose to the upper fitting on the lift cylinder (Figure 10). Turn the fitting until it is finger tight, then turn it 2 to 3 more times.

Important: Do not overtighten.

9. Creating an “S” shape with the hose, connect the free end of the hydraulic hose to the rear fitting on the hydraulic shelf (Figure 10). Turn the fitting until it is finger tight, then turn it 2 to 3 more times.

Important: Do not overtighten.

Installing the Light Bar

1. Secure the light bar to the top of the coupler tower through the rear holes using 4 bolts (3/8 x 1-1/4 inch) and self-locking nuts (3/8 inch) (Figure 11). Torque the bolts to 31 N·m (23 ft-lb).

Note: If the light bar or plow headlights comes in contact with the hood of your vehicle, install the bar using the front holes.

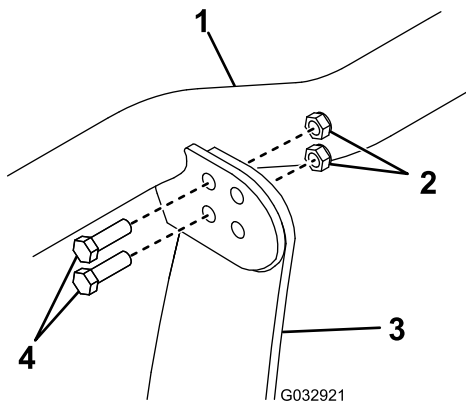

Figure 11

- | | |
|---------------------------------|-----------------------------|
| 1. Light bar | 3. Coupler tower |
| 2. Self-locking nuts (3/8 inch) | 4. Bolts (3/8 x 1-1/4 inch) |

2. Ensure that the end caps are installed on the ends of the light bar (Figure 12).

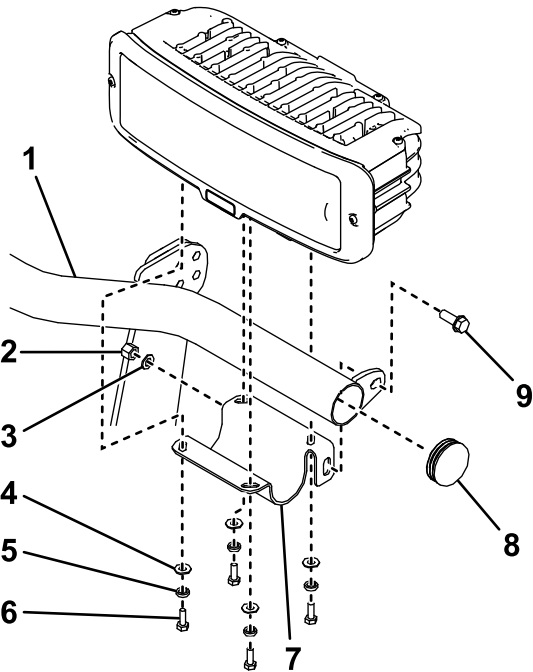

Figure 12

- | | |
|-----------------------------|------------------------------------|
| 1. Light bar | 6. Bolt (1/4 inch) |
| 2. Nylon locknut (3/8 inch) | 7. Headlight bracket |
| 3. Flat washer (3/8 inch) | 8. End cap |
| 4. Flat washer (1/4 inch) | 9. Flange-head bolt (3/8 x 1 inch) |
| 5. Split lock washer | |

3. Secure the left headlight-bracket to the light bar using a flange-head bolt (3/8 x 1 inch), a flat washer, and a nylon locknut (Figure 12).

Important: Do not use thread locking compound on these bolts.

Note: Do not tighten the fasteners at this time.

4. Secure the left headlight to the headlight bracket using 4 bolts (1/4 inch), split lock washers, and flat washers (Figure 12).

Important: Do not use thread locking compound on these bolts.

Note: Do not tighten the fasteners at this time.

5. Repeat steps 3 and 4 for the right headlight bracket and headlight.
6. Insert the headlight connectors on the wire harness to the back of the headlight housing (Figure 13). The short length connects to the left headlight and the long length connects to the right headlight.

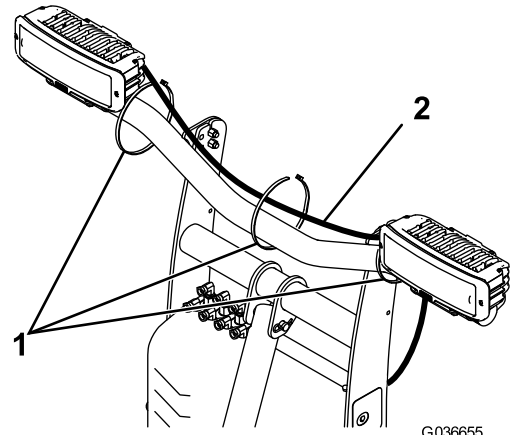

Figure 13

- | | |
|---------------|-----------------------|
| 1. Cable ties | 2. Short wire harness |
|---------------|-----------------------|

7. Secure the wire harness to the light bar using 3 cable ties as shown in Figure 13.

Installing the Blade Guides and Filling the Hydraulic Reservoir

1. Attach the blade guides to the plow blade using 4 bolts (5/16 x 1 inch) and 4 self-locking nuts (Figure 14).

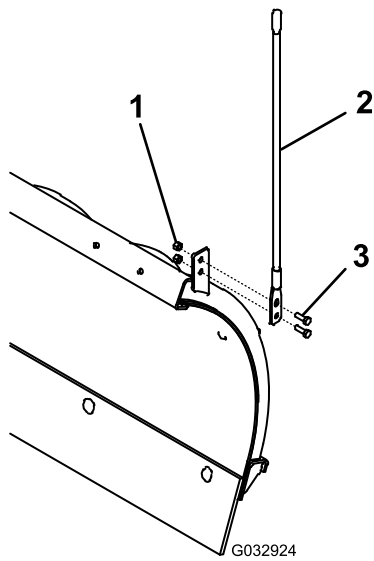

Figure 14

1. Self-locking nut (5/16 inch)
2. Blade guide
3. Bolt (5/16 x 1 inch)

2. Ensure that the lift cylinder is completely collapsed.

Note: The lights should tilt forward.

3. Remove the fill cap from the hydraulic reservoir (Figure 15).

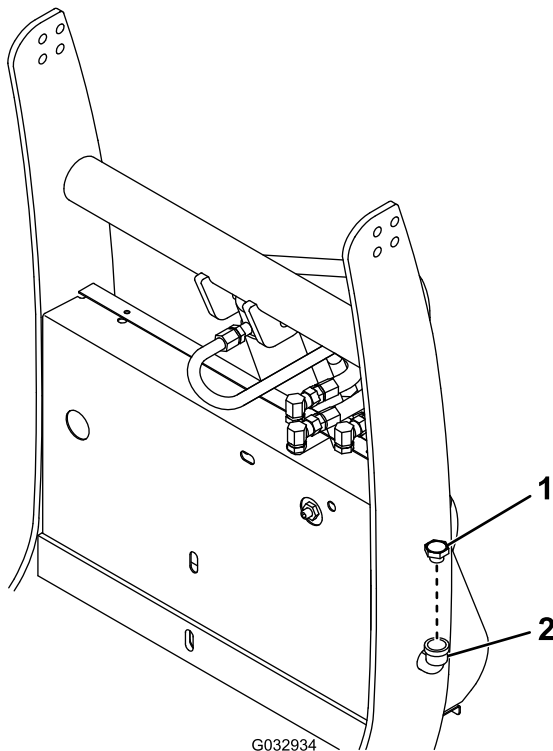

Figure 15

1. Fill cap
2. Hydraulic reservoir

4. Slowly fill the reservoir with BOSS high-performance hydraulic fluid until it accepts no more.

Note: The reservoir holds approximately 1.9 L (2 US qt) of hydraulic fluid.

5. Install the previously removed fill cap.

Installing the Wire Harness

⚠ DANGER

Vehicle engines contain moving parts and can become extremely hot, capable of causing severe burns and serious bodily harm.

Shut off the engine and allow it sufficient time to cool down before installing this kit.

⚠ DANGER

Vehicle batteries can cause dangerous electrical shocks that could lead to severe burns or death.

Disconnect your battery before installing this kit. Remove the negative cable first, then remove the positive cable.

Note: Apply dielectric grease to all electrical connections.

Note: Some vehicles require a turn signal relay kit. Contact your Authorized BOSS Dealer for more information.

Note: If your vehicle requires a headlight adapter kit, refer to [Installing the Headlight Adapters \(page 15\)](#).

1. Disconnect the wire harness plug from the back of the left vehicle headlight (Figure 16).

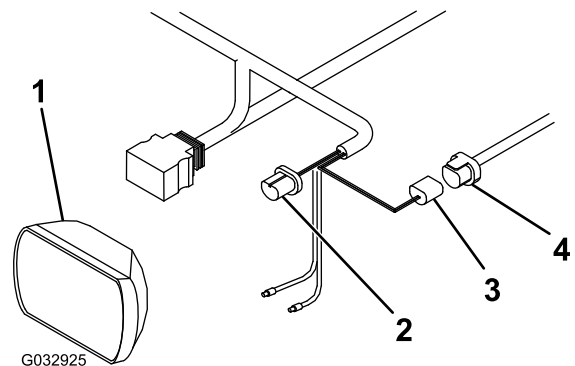

Figure 16

1. Vehicle headlight
2. Blue plug
3. Black plug
4. Vehicle wire-harness plug

2. Connect the blue plug from the long wire harness to the back of the left vehicle headlight (Figure 16).
3. Connect the black plug from the long wire harness to the previously disconnected plug on the vehicle wire harness (Figure 16).
4. Repeat steps 1 through 3 on the right vehicle headlight.
5. Connect the pink wire from the long wire harness to the right turn signal wire using a splice connector (Figure 17).

Important: Identify the circuit with a test lamp before splicing into any electrical circuit to prevent vehicle damage.

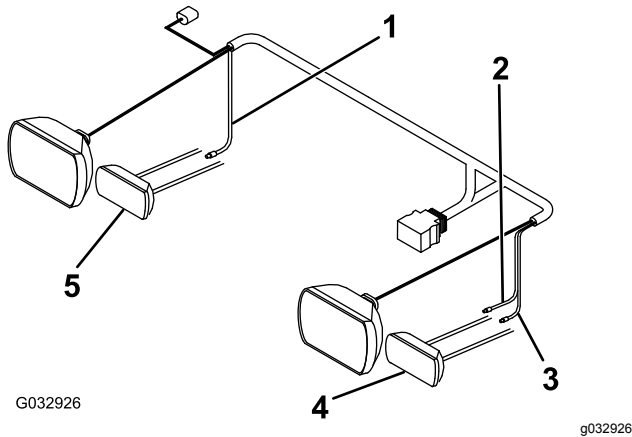

Figure 17

- | | |
|----------------|----------------------|
| 1. Pink wire | 4. Left turn signal |
| 2. Violet wire | 5. Right turn signal |
| 3. Yellow wire | |
-
6. Connect the violet wire from the long wire harness to the left turn signal wire using a splice connector (Figure 17).
 7. Connect the yellow wire from the long wire harness to the left park light wire using a splice connector (Figure 17).
 8. Ensure that the vehicle firewall is clear of obstructions.
 9. Drill a 3 cm (1-1/4 inch) diameter hole through the firewall on the driver side of the vehicle.

Note: The hole should be in an easily accessible area.
 10. Insert the split rubber grommet into the hole.
 11. Pull the plow controller connector, black/red wire, and 2 black wires into the vehicle cab through the hole in the firewall (Figure 18).

Important: Ensure that all wiring is secured in a position that avoids hot or moving parts to prevent damage to the vehicle or plow.

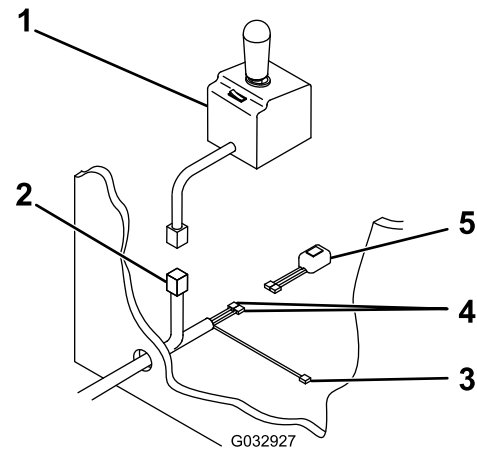

Figure 18

- | | |
|-------------------------|----------------------------|
| 1. Plow controller | 4. Black wires |
| 2. Controller connector | 5. Headlight toggle switch |
| 3. Black/red wire | |

-
12. Connect the 2 black wires to the headlight toggle switch (Figure 18).
 13. Determine where you will mount the headlight toggle switch and clean the area thoroughly.

Note: Allow the area to dry completely after cleaning.
 14. Remove the adhesive backing and press the toggle switch to the clean area of the dashboard for 30 seconds.
 15. Plug the controller connector into the plow controller.
 16. Mount the plow controller; refer to [Mounting the Plow Controller \(page 16\)](#).
 17. Connect the black/red wire to a keyed 12 V + ignition source.

Note: Connecting the wire to a source that is not keyed can cause the battery to drain.
 18. Connect the white/black wire from the wire harness to the small post on the pump solenoid (Figure 19).

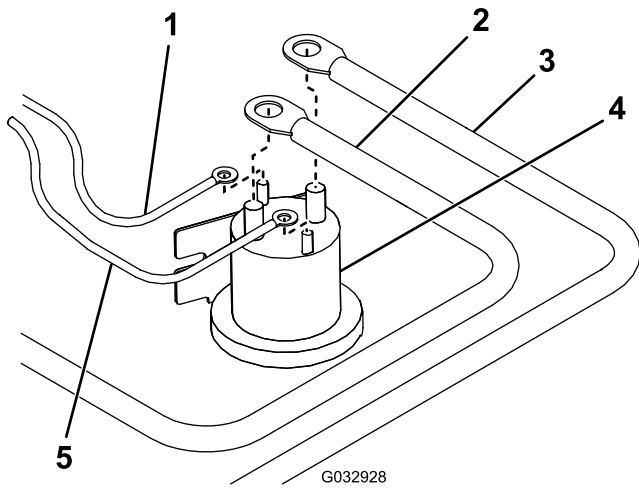

Figure 19

- | | |
|---------------------------|------------------|
| 1. White/black wire | 4. Pump solenoid |
| 2. Battery cable | 5. Brown wire |
| 3. Red power/ground cable | |

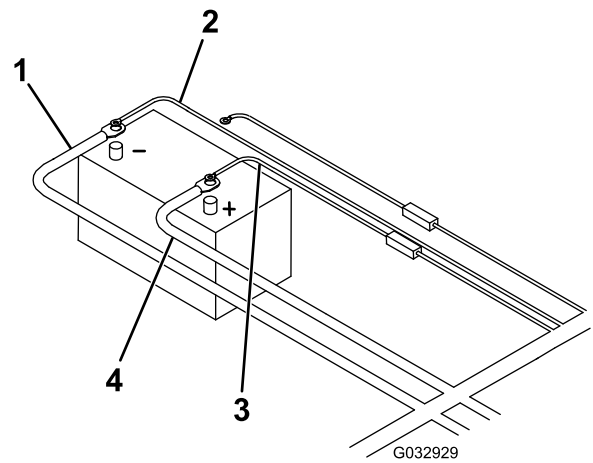

Figure 20

- | | |
|-----------------------------|---------------------------|
| 1. Black power/ground cable | 4. Red fused wire |
| 2. Brown wire | 5. Red power/ground cable |
| 3. Red/white fused wire | |

19. Connect the brown wire from the wire harness to the other small post on the pump solenoid (Figure 19).

Note: The wires may go on either small post, but should not share a post.

20. Mount the pump solenoid inside the engine compartment of the vehicle, ensuring that it stays in an upright position and does not contact the body, hood, or other conductive material on the vehicle.

21. Connect the red power/ground cable to the large post on the pump solenoid (Figure 19).

22. Connect the battery cable to the other large post on the pump solenoid (Figure 19).

Note: The wires may go on either large post, but should not share a post.

23. Connect the black power/ground cable to the negative (-) battery terminal (Figure 20).

24. Connect the brown wire to the negative (-) battery terminal (Figure 20).

25. Connect the free end of the battery cable to the positive (+) battery terminal (Figure 20).

26. Connect the red, fused wire and the red/white fused wire to the positive (+) battery terminal (Figure 20).

27. Mount the truck-side, wire harness plow connector to the lower part of the bumper using the control harness mounting bracket (Figure 21).

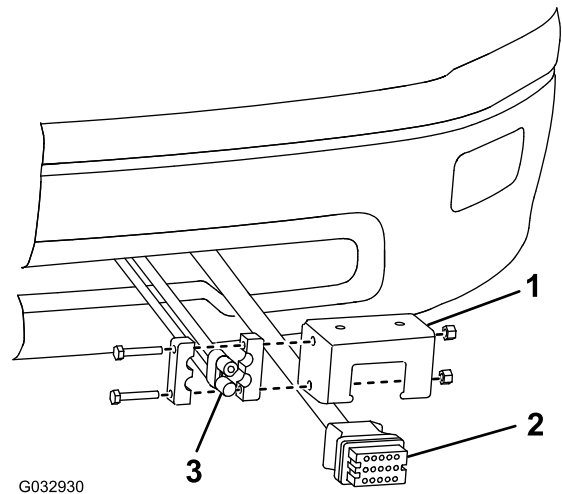

Figure 21

- | | |
|-------------------------------------|-----------------------------------|
| 1. Control-harness mounting bracket | 3. Power/ground connector bracket |
| 2. Plow connector | |

28. Mount the black and red power/ground connector to the control harness mounting bracket (Figure 21).

29. Mount the relay pack to the inside of the engine compartment using a sheet-metal screw (Figure 22).

Note: Ensure that the relay pack is mounted in the upright position.

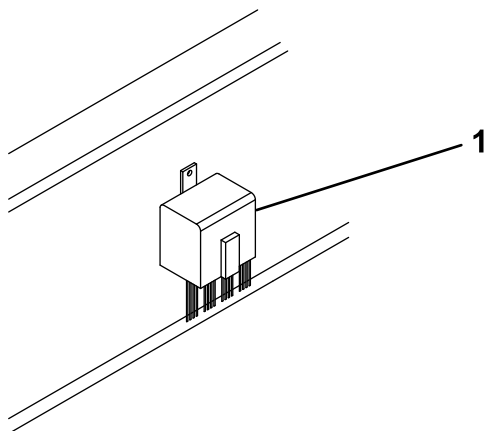

Figure 22

g270624

1. Relay pack

30. Locate the vehicle option connector and align it according to the table below:

Note: If your vehicle is not listed in the table, use the standard orientation.

Note: If the vehicle option connector is not properly oriented, the lights on the plow do not function correctly.

Models	Orientation
1992 and newer Ford models 1988 and newer GM models 2003 and newer Dodge models Dodge models with a 4-headlight system	<p>Standard Orientation</p> <p>1. Red/yellow wire 3. Red/yellow wire 2. White/yellow wire 4. White/yellow wire</p>
1987 and older GM models with a 4-headlight system 1987 to 1991 Ford models (9004 bulb) 1994 to 2002 Dodge models with a 2-headlight system (9004 bulb)	<p>Reverse Orientation</p> <p>1. White/yellow wire 3. Red/yellow wire 2. Red/yellow wire 4. White/yellow wire</p>

31. Connect the red/white wire to the battery according to the table below:

Note: If the red/white wire is installed incorrectly, the low beams do not illuminate when the plow high-beams are on.

Models	Wire Placement
1999 to 2002 Chevrolet and GMC models 1999 to 2002 Dodge models 2000 to 2006 Toyota models	Negative (-) battery terminal
All other vehicles	Positive (+) battery terminal

32. Secure the wire harness.

33. Attach the snowplow to the vehicle; refer to [Mounting the Snowplow \(page 17\)](#).

34. Test the wire harness installation as follows:

Note: Turn the ignition to the ON position before testing.

Note: If any of the lights fail to work, check the wiring and make any corrections.

A. To test the vehicle low-beam lights, do the following:

- Switch the vehicle headlights to the ON position.
- Switch the plow headlight toggle switch to the TRUCK position.
- Ensure that the low-beam light indicator on the vehicle is illuminated.

Only the vehicle low-beam lights should be illuminated.

B. To test the vehicle high-beam lights, do the following:

- Switch the vehicle headlights to the HIGH-BEAM position.
- Switch the plow headlight toggle switch to the TRUCK position.
- Ensure that the high-beam light indicator on the vehicle is illuminated.

Only the vehicle high-beam lights should be illuminated.

C. To test the plow low-beam lights, do the following:

- Switch the vehicle headlights to the ON position.
- Switch the plow headlight toggle switch to the PLOW position.
- Ensure that the low-beam light indicator on the vehicle is illuminated.

Only the plow low-beam lights should be illuminated.

D. To test the plow high-beam lights, do the following:

- Switch the vehicle headlights to the HIGH-BEAM position.

- Switch the plow headlight toggle switch to the PLOW position.
- Ensure that the high-beam light indicator on the vehicle is illuminated.

Only the plow high-beam and low-beam lights should be illuminated.

- E. To test the plow and vehicle turn signals, do the following:
- Activate the left or right vehicle turn signal.
 - Ensure that the appropriate vehicle turn-signal indicator is illuminated.

Both the vehicle and plow turn signals should flash.

- F. To test the plow and vehicle park lights, activate the vehicle park lights.

All the plow and vehicle park lights should be on.

Installing the Headlight Adapters

Optional

For Two-Headlight Vehicles

1. Disconnect the wire harness plug from the back of the left vehicle headlight (Figure 23).

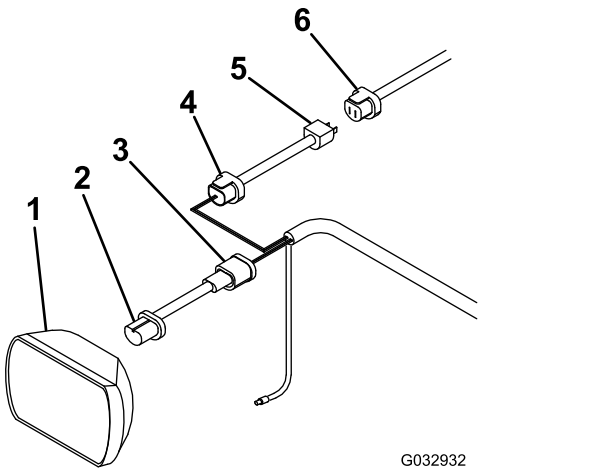

Figure 23

- | | |
|----------------------|------------------------------|
| 1. Vehicle headlight | 4. Blue plug |
| 2. Headlight adapter | 5. Headlight adapter |
| 3. Black plug | 6. Vehicle wire-harness plug |

2. Connect the headlight adapter to the back of the left vehicle headlight (Figure 23).
3. Connect the black plug from the headlight adapter to the long wire harness (Figure 23).

4. Connect the blue plug from the headlight adapter to the blue plug on the long wire harness (Figure 23).
5. Connect the free end of the headlight adapter to the previously disconnected plug on the vehicle wire harness (Figure 23).
6. Repeat steps 1 through 5 on the right vehicle headlight.
7. Continue the wire harness installation from step 5 of [Installing the Wire Harness](#) (page 11).

For Four-Headlight Vehicles

1. Disconnect the wire harness plugs from the back of the left vehicle headlights (Figure 24).

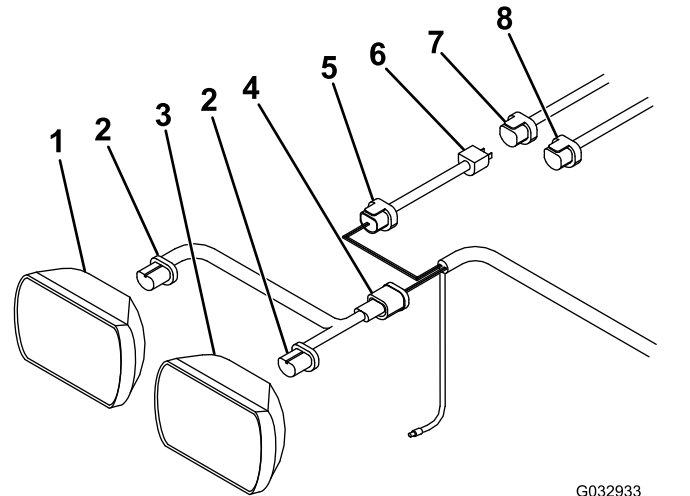

Figure 24

- | | |
|----------------------------|---------------------------|
| 1. Outer vehicle headlight | 5. Blue plug |
| 2. Headlight adapter | 6. Headlight adapter |
| 3. Inner vehicle headlight | 7. Vehicle low-beam plug |
| 4. Black plug | 8. Vehicle high-beam plug |

2. Connect the 2 ends of the headlight adapter to the back of the left vehicle headlights (Figure 24).
3. Connect the black plug from the headlight adapter to the long wire harness (Figure 24).
4. Connect the blue plug from the headlight adapter to the blue plug on the long wire harness (Figure 24).
5. Connect the free end of the headlight adapter to the previously disconnected low-beam plug on the vehicle wire harness (Figure 24).
6. Grease, tuck, and secure the previously disconnected high-beam plug on the vehicle wire harness (Figure 24).

Note: You will not use this connector.

7. Repeat steps 1 through 6 on the right vehicle headlights.

- Continue the wire harness installation from step 5 of [Installing the Wire Harness \(page 11\)](#).

Mounting the Plow Controller

Mounting the Joystick Controller

Note: Mount the controller in the cab in a dry area where it does not interfere with vehicle operation or visibility.

⚠ DANGER

The controller could cause serious injury if contacted during a crash.

Mount the controller in a location that vehicle occupants will not contact during a crash.

- Determine the best location and configuration for your controller mounting-bracket; refer to [Figure 25](#) for possible configurations.
- Secure the mounting brackets to the vehicle and joystick controller using 8 to 10 bolts (#8), washers (#10), and nuts (#8) as shown in [Figure 25](#).
- Continue the wire harness installation from step 17 of [Installing the Wire Harness \(page 11\)](#).

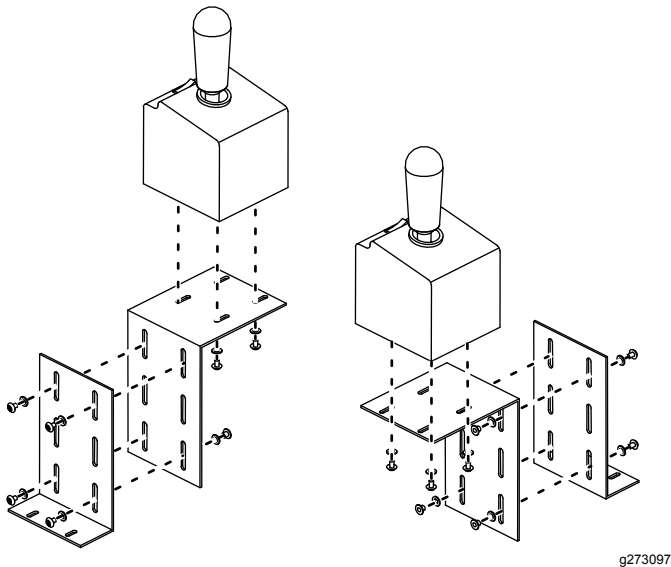

Figure 25

g273097

Mounting the SmartTouch2™ Controller

Note: Mount the controller in the cab in a dry area where it does not interfere with vehicle operation or visibility.

Important: Do not install the swivel mount when temperatures are below 16 °C (60 °F).

⚠ DANGER

The controller could cause serious injury if contacted during a crash.

Mount the controller in a location that vehicle occupants will not contact during a crash.

- Determine the mounting location for the controller.
- Clean the location with the provided alcohol wipe and dry it with a cloth or paper towel.
- Clean the back of the swivel mount ([Figure 26](#)) with the alcohol wipe and then dry it.

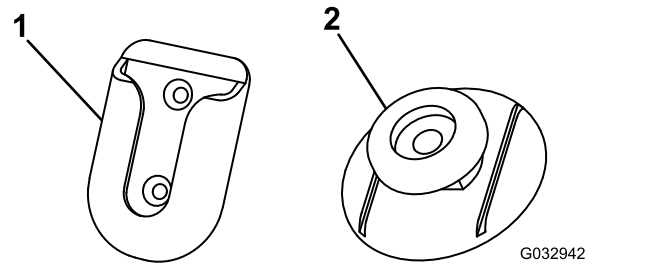

Figure 26

G032942
g032942

- Swivel mount
- Mounting tab

- Remove the backing from 1 side of the adhesive and apply it to the back of the swivel mount.
- Remove the remaining backing from the swivel-mount adhesive and press the swivel mount to the clean area of the dashboard for 30 seconds.

Important: Once the mount is placed, you cannot remove it without destroying the adhesive.

- Clean the back of the controller with the alcohol wipe and then dry it.
- Remove the backing from 1 side of the adhesive and apply it to the back of the mounting tab ([Figure 26](#)).
- Remove the remaining backing from the controller adhesive and press the mounting tab to the controller for 30 seconds.
- Let the swivel mount rest unused for 72 hours before sliding the controller into the mounting bracket.

Important: Mounting the controller immediately may cause the adhesive to fail.

- Continue the wire harness installation from step 17 of [Installing the Wire Harness \(page 11\)](#).

Mounting the Snowplow

Note: The vehicle must be running before starting this procedure.

1. Activate the FLOAT feature on your plow controller.
2. Line up the vehicle with the snowplow and slowly drive forward until the lower pin contacts the push-beam pin receiver (Figure 27).

Note: Ensure that the pushbeam is at the correct height for your plow. Refer to [Specifications \(page 22\)](#) for the recommended pushbeam height. Refer to [Adjusting the Pushbeam Height \(page 17\)](#) if the pushbeam is not at the correct height.

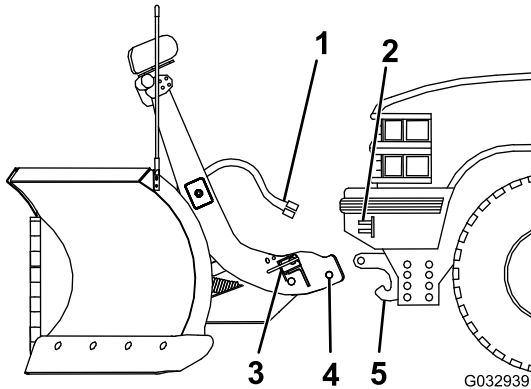

Figure 27

1. Plow wire harness
2. Vehicle wire harness
3. Coupler
4. Lower pin
5. Pin receiver

3. Turn the levers on the couplers to the ON position (Figure 28).

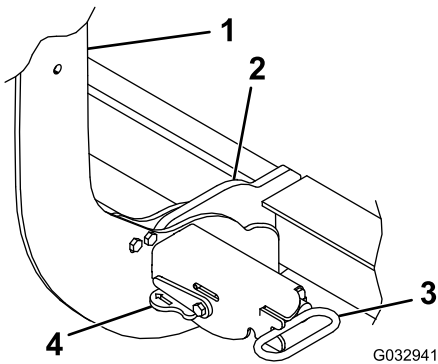

Figure 28

1. Coupler tower
2. Pin receiver
3. Coupler spring pin
4. Coupler lever

4. Remove the electrical-plug dust-covers and connect the plow wire harness to the vehicle wire harness (Figure 27).

5. Push the SmartHitch2 switch on the side of the coupler tower upward and raise the tower until the coupler spring pins snap in (Figure 29).

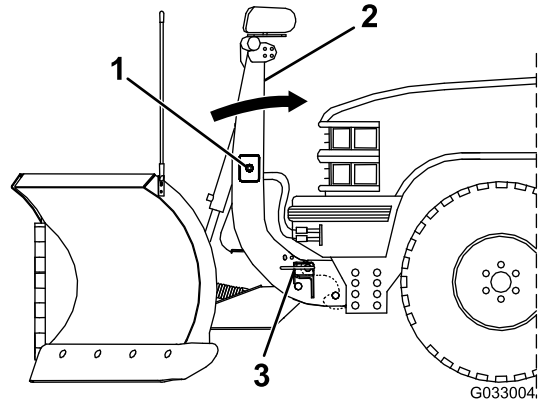

Figure 29

1. SmartHitch2 switch
2. Coupler tower
3. Coupler spring pin

6. Ensure that both coupler spring pins have fully engaged the coupler (Figure 28).

Note: Move the coupler tower until the spring pins engage completely.

7. Switch the headlight toggle switch to the PLOW position.

Adjusting the Pushbeam Height

Optional

1. Measure the distance from the ground to the coupler spring-pin holes on the undercarriage pushbeam (Figure 30). The measurement should match the height listed for your plow in [Specifications \(page 22\)](#).
2. If the pushbeam is not at the correct height, remove the fasteners securing the pushbeam to the undercarriage (Figure 30).
3. Move the pushbeam up or down and secure it with the previously removed hardware.
4. Torque the fasteners to 76 N·m (56 ft-lb).

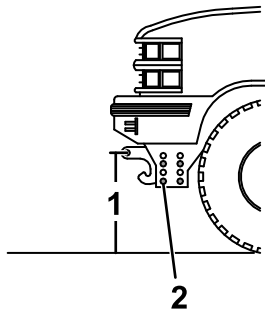

Figure 30

g230889

1. Measure this distance.
2. Fastener

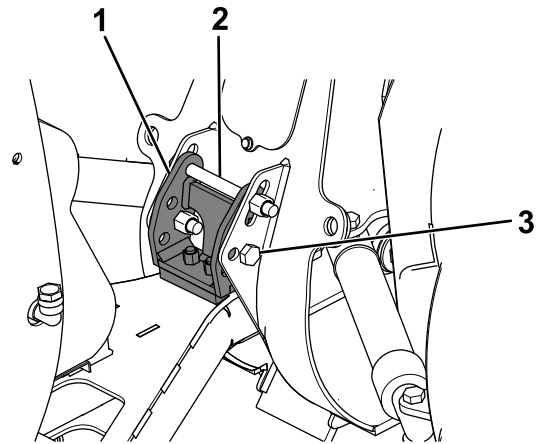

Figure 32

g270775

1. Bumper stop
2. Top fastener
3. Side fastener

Leveling the Plow Blades

1. Park the vehicle on a level surface and lower the plow in the V-position. If the plow is not flush against the ground, proceed to step 2. If the plow is flush against the ground, proceed to step 10.
2. Loosen and carefully remove the fasteners from the trip-spring eye bolts (Figure 31).

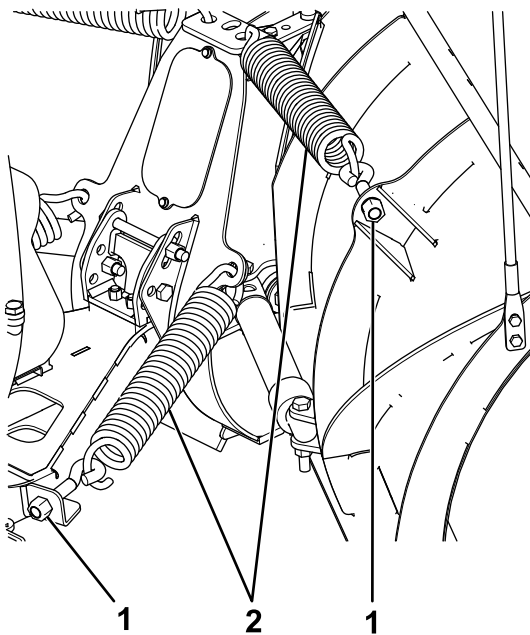

Figure 31

g270743

1. Fasteners
2. Trip spring

3. Loosen the fasteners securing the top of the bumper stop to the blade center section (Figure 32).

4. Remove the 2 fasteners securing the sides of the bumper stop to the blade center section (Figure 32).
5. Slide the bumper stop to the desired position and secure it to the blade center section using the previously removed side fasteners.

Note: Slide the bumper stop down to lower the center of the plow; slide the bumper stop up to raise the center of the plow.
6. Tighten the fasteners securing the top of the bumper stop.
7. Torque the fasteners to 76 N·m (56 ft-lb).
8. Secure the trip-spring eye bolts with the previously removed fasteners (Figure 31).
9. Tighten the fasteners until there is a gap of 0.8 mm (1/32 inch) between the trip spring coils.
10. Raise the plow, then lower the blade in the scoop position. If the plow is not flush against the ground, repeat steps 2 through 9.

Aiming the Headlights

Important: Certify that the installation of the snowplow lights conforms to applicable federal motor vehicle safety standards.

1. Park the vehicle on a level surface 7.5 m (25 ft) away from a matte white screen or garage door.

Note: The screen should be perpendicular to both the ground and the front of the vehicle.
2. Ensure that the vehicle is equipped for normal operation with the snowplow attached and in the raised position.
3. Perform the following actions to ensure optimal headlight alignment:

- Remove any ice or mud from under the fenders.
 - Ensure that all tires are fully and evenly inflated.
 - Check vehicle springs for sag or broken leaves.
 - Check the function of any level ride controls.
 - Stabilize the suspension by rocking the vehicle sideways.
 - Ensure that there is no load in the vehicle other than the driver.
 - Clean the headlights and matte white screen.
4. Mark the vertical vehicle centerline on the screen (Figure 33).

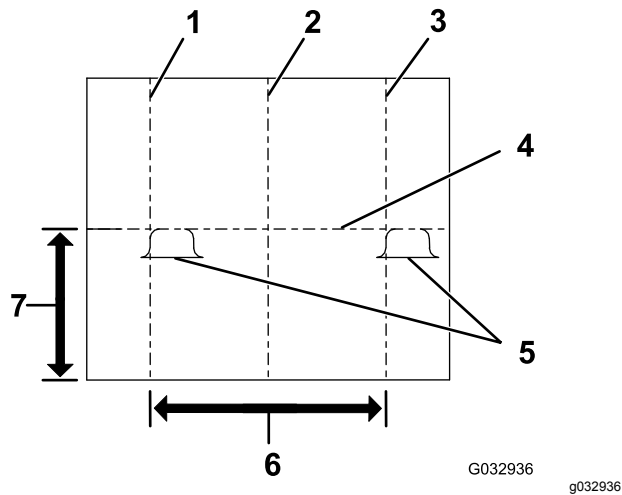

Figure 33

- | | |
|--|--|
| 1. Vertical left headlight centerline | 5. Brightest points |
| 2. Vehicle centerline | 6. Distance between headlight centers |
| 3. Vertical right headlight centerline | 7. Distance from ground to headlight centers |
| 4. Horizontal headlight centerline | |

5. Mark the vertical headlight centerline on the screen (Figure 33).
6. Mark the horizontal headlight centerline on the screen (Figure 33).

Note: The horizontal headlight centerline should be the distance from the ground to the center of the headlight.

7. Adjust the plow headlights until the brightest part of the plow low-beam lights are aligned as shown in Figure 33.
8. Tighten the 4 bolts securing each headlight to the headlight brackets and torque them to 8 N·m (6 ft-lb).

Product Overview

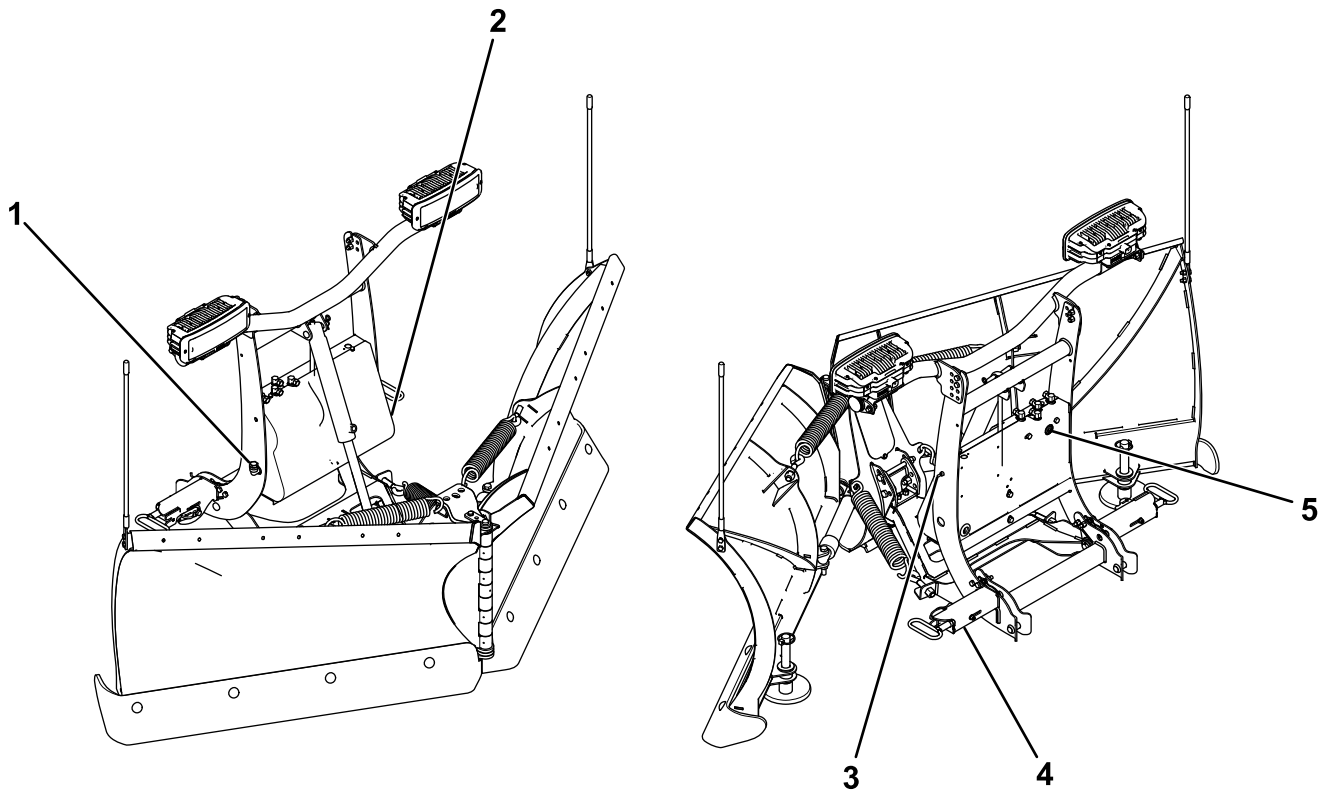

Figure 34

g270730

- 1. Hydraulic reservoir fill elbow
- 2. Coupler-tower cover
- 3. SmartHitch2 switch

- 4. Spring pin
- 5. Hydraulic flow-control valve

Controls

Become familiar with all the controls before you operate the plow.

SmartHitch2 Switch

The SmartHitch2 switch controls the movement of the coupler tower to facilitate plow attachment and removal. With the controller in the Float mode, press the switch up to raise the tower and down to lower the tower.

Headlight Toggle Switch

The headlight toggle switch controls which set of headlights is being used. Move the switch to the TRUCK position to use the headlights on the vehicle. Move the switch to the PLOW position to use the headlights on the plow.

Spring Pins

The spring pins secure the plow to the vehicle pushbeam. Turn the levers toward the coupler tower to lock the spring pins. Turn the levers away from the coupler tower to unlock the spring pins.

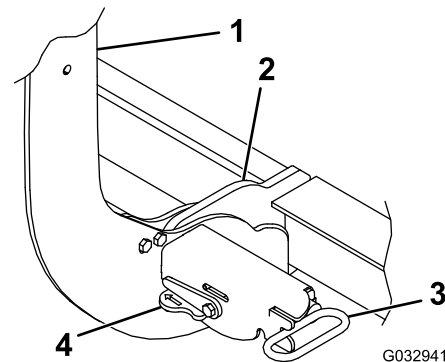

G032941

g032941

Figure 35

- 1. Coupler tower
- 2. Pin receiver
- 3. Spring pin
- 4. Lever

Joystick Controller

The joystick controller operates the movement of the snowplow. You can rotate the Raise/Lower switch for right or left hand operation by pulling up the joystick and rotating it to the desired position.

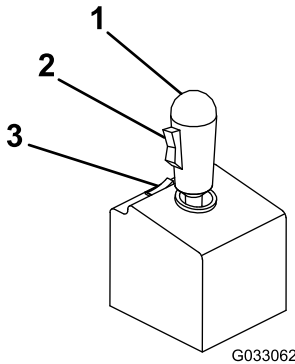

Figure 36

- 1. Joystick
- 2. Raise/Lower switch
- 3. On/Off switch

- On/Off switch—turns the plow controller on and off. A red light illuminates when the controller is on.

Note: Turn off the controller when not in use to prevent accidental activation of the plow.

- Raise/Lower switch—raises or lowers the plow blade. Press the switch up to raise the plow. Press the switch down to lower the plow.
- Directional joystick—controls the direction that the plow moves
 - To activate the Float feature, press the Raise/Lower switch down until it clicks into the detent position, allowing the plow blade to follow the contour of the ground. The switch stays in the Float position until it is pressed up again.
 - To move the right plow wing out, push the joystick diagonally right and forward.
 - To move the left plow wing out, push the joystick diagonally left and forward.
 - To make the scoop shape with the plow, move both wings out and push the joystick forward.
 - To make the V shape with the plow, move both wings in and pull the joystick backward.
 - To move the right plow wing in, pull the joystick diagonally right and backward.
 - To move the left plow wing in, pull the joystick diagonally left and backward.
 - To angle the entire plow blade right, move the right wing in, the left wing out, and push the joystick right.

- To angle the entire plow blade left, move the right wing out, the left wing in, and push the joystick left.

SmartTouch2 Controller

The SmartTouch2 controller operates the movement of the snowplow.

Note: Plows equipped with D-Force must have a SmartTouch2 controller with a red center button.

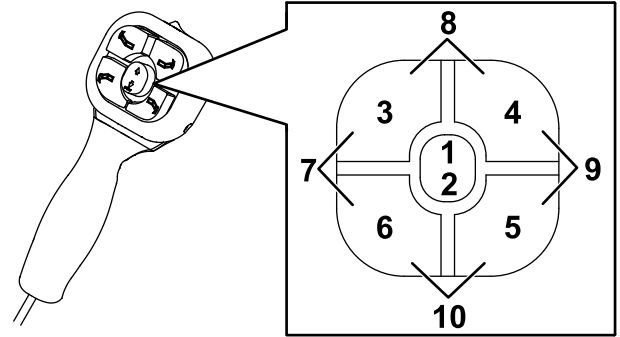

Figure 37

- 1. Raise button
- 2. Lower button
- 3. Left Wing Out button
- 4. Right Wing Out button
- 5. Right Wing In button
- 6. Left Wing In button
- 7. Angle left
- 8. Scoop
- 9. Angle right
- 10. V

- On/Off switch—turns the plow controller on and off. A green light illuminates when the controller is on.

Note: Turn off the controller when not in use to prevent accidental activation of the plow.

- Raise button—raises the plow blade. Pressing the button quickly twice automatically raises the blade when Express Raise mode is enabled.
- Lower button—lowers the plow blade and activates the FLOAT and D-FORCE features.
 - FLOAT—double tapping the button or holding it for 2 seconds automatically lowers the blade and activates the FLOAT feature, allowing the plow blade to follow the contour of the ground. A red light illuminates when the FLOAT feature is active.
 - D-FORCE (optional)—if your plow is equipped with the D-FORCE feature, double tapping the button a second time activates it, applying a downward force on the blade to improve back blading. An orange light illuminates when the D-FORCE feature is active.

Note: You can only activate the D-FORCE feature twice before the plow must be raised.

Important: Use the D-Force feature only while back dragging to prevent damage to the plow or vehicle.

- Left Wing Out button—moves the left wing out
 - Right Wing Out button—moves the right wing out
 - Left Wing In button—moves the left wing in
 - Right Wing In button—moves the right wing in
 - Sleep mode—If you do not use the controller for 20 minutes, it enters sleep mode and the controller lights flash green and red. Turn the controller off and on again to deactivate the sleep mode.
- To angle the entire plow blade right, press the Right Wing In and Right Wing Out buttons simultaneously until the blades are fully angled.
 - To angle the entire plow blade left, press the Left Wing In and Left Wing Out buttons simultaneously until the blades are fully angled.
 - To make the scoop shape with the plow, press the Left Wing Out and Right Wing Out buttons simultaneously until the blades are fully extended.
 - To make the “V” shape with the plow, press the Left Wing In and Right Wing In buttons simultaneously until the blades are fully retracted.

To perform different tasks, you can configure the plow wings as follows:

Specifications

Blade width	2.29 m (90 inches)
Blade height	81 cm (32 inches)
Recommended push beam height	36.8 cm (14-1/2 inches)
Weight	222 kg (490 lb)

Troubleshooting

Problem	Possible Cause	Corrective Action
The pump motor does not run.	<ol style="list-style-type: none"> 1. The power/ground cables or control cables are not connected. 2. The pump motor has failed or the pump has seized 3. The cable between the battery and the solenoid is disconnected or broken. 4. The solenoid has failed. 5. Power from the relay is disconnected. 	<ol style="list-style-type: none"> 1. Connect the cables. 2. Check for voltage at the pump motor while the ignition switch is on and the Raise button is pressed on the controller. If voltage is present, the motor brushes or pump/motor assembly may be replaced. 3. Check for power to the solenoid by testing for voltage between both large terminals and ground. If voltage is not present between one large terminal and ground, connect or replace the cable. 4. Check for voltage between the other large terminal of the solenoid and ground while jumping power to the small terminal with the white/black wire. If no voltage is present, replace the solenoid. If voltage is present, connect or replace the wire from the small terminal of the solenoid to ground. 5. Test the voltage between the black wire and ground at the white 9-pin connector. If no voltage is present, connect the relay. If voltage is present, check the wiring and controller switches.
The pump continues to run while the switch is in neutral.	<ol style="list-style-type: none"> 1. The solenoid has failed in the closed position. 2. There is a short between the black and white/black wire in the controller. 3. The switch has failed. 	<ol style="list-style-type: none"> 1. Disconnect the controller and turn the ignition on. If the pump continues to run, quickly remove power to the pump by disconnecting the power/ground cables to the plow and replace the solenoid. 2. Disconnect the controller and turn the ignition on. If the pump stops running, replace the wire. 3. Replace the switch.
The plow does not lower.	<ol style="list-style-type: none"> 1. The power/ground cables or control cables are not connected. 2. The flow-control valve is closed. 3. The wiring on the valve block is not connected. 4. The solenoid valve or valve coil has failed. 5. Power from the relays is disconnected. 	<ol style="list-style-type: none"> 1. Connect the cables if they are not connected. 2. Place the controller in neutral, then open the flow-control valve. 3. Refer to the wiring schematic. 4. Check for voltage between the solenoid valve terminal and ground while the ignition switch is on and the controller is in the Float position. If voltage is present, replace the valve or valve coil. 5. Check the voltage between the black wire and ground at the white 9-pin connector. If no voltage is present, connect the relays. If voltage is present, check the wiring and switch off the controller.
The plow lowers too fast.	<ol style="list-style-type: none"> 1. The flow-control valve is open too much. 	<ol style="list-style-type: none"> 1. Close the flow-control valve to the desired drop speed.

Problem	Possible Cause	Corrective Action
The plow does not raise or raises slowly.	<ol style="list-style-type: none"> 1. Check the hydraulic-fluid level. 2. Check that the power/ground cables and the control cable are connected properly. 3. Check the wiring on the valve block for proper connections. 4. Load a test battery. 5. Check the pressure at the pressure port of the pump. 6. Check the RAISE control solenoid valve. 	<ol style="list-style-type: none"> 1. The hydraulic-fluid level should be within 2 cm (3/4 inch) of the top of the reservoir when lowered and in the V position. 2. Connect the cables if they are not connected. 3. Refer to the manifold wiring diagram included with your <i>Owner's Manual</i>. 4. Replace the battery if it is weak or defective. 5. If the pressure is less than 2,500 psi (at the end of the lift), the motor brushes may be defective, the pump pressure relief valve may be contaminated, damaged, or set to less than 2,500 psi, or the pump may be worn. 6. If the RAISE solenoid valve is not opening completely, replace it.
The plow angles while plowing.	<ol style="list-style-type: none"> 1. The ANGLE control solenoid valve is contaminated or damaged. 2. The pressure relief valve is contaminated or damaged. 3. The pressure relief valve is set incorrectly. 	<ol style="list-style-type: none"> 1. Clean or replace the ANGLE control solenoid valve. 2. Clean or replace the pressure relief valve. 3. Contact your authorized BOSS dealer.
The plow does not angle or angles slowly.	<ol style="list-style-type: none"> 1. The hydraulic-fluid level is incorrect. 2. The power/ground cables and/or the control cables are not connected properly. 3. The wiring connections on the valve block are not connected properly. 4. The battery is damaged or depleted. 5. The ANGLE control solenoid valve does not open completely. 	<ol style="list-style-type: none"> 1. Ensure that the hydraulic-fluid level should be within 2 cm (3/4 inch) of the top of the reservoir when the plow is lowered. 2. Connect the cables if they are not connected. 3. Refer to the manifold wiring schematic included with your <i>Owner's Manual</i>. 4. Load a test battery and replace it if necessary. 5. Replace the ANGLE control solenoid valve.
Fluid leaks from the lift cylinders.	<ol style="list-style-type: none"> 1. The fittings are loose or the O-rings are damaged. 2. The rods are pitted or rough. 	<ol style="list-style-type: none"> 1. Tighten loose fittings. See your authorized BOSS dealer for a seal kit. 2. Polish them with a copus cloth or extra fine steel wool.
The vehicle battery dies when the vehicle is turned off.	<ol style="list-style-type: none"> 1. The wire harness isn't connected to a keyed fuse source. 	<ol style="list-style-type: none"> 1. Connect the wire harness to a keyed fuse source; refer to the wire schematic.
The vehicle battery dies when all of the switches are in the Neutral position.	<ol style="list-style-type: none"> 1. There is a short in the controller wiring. 2. There is a short in the wire harness. 3. There is a short in the valve coils. 	<ol style="list-style-type: none"> 1. Repair or replace the controller. 2. Repair or replace the wire harness. 3. Replace the valve coils.
The plow lights are dim, do not come on, or flicker.	<ol style="list-style-type: none"> 1. The electrical connections are corroded or damaged.. 2. The wrong headlight adapters are being used. 3. The headlight adapters are not installed correctly. 4. The relays are corroded or broken. 	<ol style="list-style-type: none"> 1. Clean and repair the terminals. 2. Replace the headlight adapters with the correct ones. 3. Correctly install the headlight adapters. 4. Clean or replace the relays.

Problem	Possible Cause	Corrective Action
The turn signals flash at a rapid rate.	<ol style="list-style-type: none"> 1. The wrong headlight adapters are being used. 2. The headlight adapters are not installed correctly. 3. The wrong flasher is being used. 	<ol style="list-style-type: none"> 1. Replace the headlight adapters with the correct ones. 2. Correctly install the headlight adapters. 3. Replace the vehicle flasher with a heavy-duty 6 A flasher.
There is no high-beam indicator light, or it does not function properly.	<ol style="list-style-type: none"> 1. The wrong headlight adapters are being used. 2. The headlight adapters are not installed correctly. 	<ol style="list-style-type: none"> 1. Replace the headlight adapters with the correct ones. 2. Correctly install the headlight adapters.
The blade trips too easily.	<ol style="list-style-type: none"> 1. The trip springs are loose or damaged. 2. The pushbeam is not at the correct height. 	<ol style="list-style-type: none"> 1. Tighten the springs or replace them if they are damaged. 2. Adjust the push beam to the proper height.
The plow does not clean up snow from low areas.	<ol style="list-style-type: none"> 1. The controller is not in the FLOAT position. 	<ol style="list-style-type: none"> 1. Activate the FLOAT feature on the controller.
Fluid is running out of the fill cap of the hydraulic pump.	<ol style="list-style-type: none"> 1. The terrain is too steep. 2. The pump reservoir is overfilled. 3. The plow is hitting snowbanks too hard. 	<ol style="list-style-type: none"> 1. Avoid steeply sloped areas. 2. The hydraulic fluid level should be within 2 cm (3/4 inch) of the top of the reservoir. 3. Do not plow recklessly.
The pump chatters when raising the plow or extending the wing(s).	<ol style="list-style-type: none"> 1. Make sure that the vehicle is on and the controller is in the FLOAT position. 2. Make sure that the controller is in the FLOAT position. 3. Check valve block and the SmartHitch2 switch for proper connections. 	<ol style="list-style-type: none"> 1. Turn the vehicle on and put the controller in the FLOAT position. 2. If the controller comes out of the FLOAT position when using the SmartHitch2 controller, replace the controller. 3. Refer to the manifold wiring diagram included with your <i>Owner's Manual</i>.
The SmartHitch2 does not attach to the plow.	<ol style="list-style-type: none"> 1. The controller is not in the FLOAT position. 2. The controller is malfunctioning. 3. The valve block and SmartHitch2 switch are not properly connected. 	<ol style="list-style-type: none"> 1. Turn the vehicle on and put the controller in the FLOAT position. 2. Replace the controller. 3. Check valve block and the SmartHitch2 switch for proper connections; refer to the manifold wiring diagram included with your <i>Owner's Manual</i>.
The plow lights and truck lights are on at the same time.	<ol style="list-style-type: none"> 1. The vehicle wire harness is plugged into the vehicle headlight. 	<ol style="list-style-type: none"> 1. Check the wiring connections; refer to the wiring diagram included with your <i>Owner's Manual</i>.
All of the plow and vehicle lights are on at the same time.	<ol style="list-style-type: none"> 1. The headlight adapters are not installed correctly. 	<ol style="list-style-type: none"> 1. Correctly install the headlight adapters.
While trying to raise the plow, the wing(s) extend prior to raising the plow and do(es) not retract.	<ol style="list-style-type: none"> 1. The pressure or return lines are incorrectly routed. 	<ol style="list-style-type: none"> 1. Ensure that the pressure line is connected from the "P" on the pump to the "P" on the valve manifold, and the return line is connected from the "T" on the pump to the "T" on the valve manifold.
The wings drift back when extended.	<ol style="list-style-type: none"> 1. The wing-return-solenoid valve on the manifold is contaminated. 2. The pressure-relief valve is contaminated. 	<ol style="list-style-type: none"> 1. Clean or replace it. 2. Clean or replace it.

Problem	Possible Cause	Corrective Action
The wing(s) do(es) not extend or extend slowly when the motor runs.	<ol style="list-style-type: none"> 1. The hydraulic-fluid level is low. 2. The power/ground cables or the control cable are not connected. 3. The wiring on the valve block is not connected. 4. The battery if it is weak or needs replacing. 5. The motor brushes are bad. 6. The pump pressure relief valve is set to less than 172 bar (2,500 psi), contaminated, or damaged. 7. The pump is worn 8. The Wing Out control solenoid valve is not opening completely. 9. The wiring or control box is not connected. 	<ol style="list-style-type: none"> 1. Check the hydraulic-fluid level; refer to the Checking the Hydraulic Fluid section. 2. Connect the cables. 3. Refer to the wiring schematic. 4. Load a test battery and replace it if necessary. 5. Check the motor brushes and replace them if necessary. 6. Ensure that the pressure is set to 172 bar (2,500 psi). Check the pressure again. If it is less than 172 bar (2,500 psi) at the end of the lift, clean or replace the pressure relief valve. 7. Replace the pump. 8. Replace it. 9. Refer to the wiring schematic.
The wing(s) extend, but do(es) not retract or retract slowly.	<ol style="list-style-type: none"> 1. The power/ground cables or control cable are not connected. 2. The wiring on the valve block is not connected. 3. The solenoid valve or valve coil has failed. 	<ol style="list-style-type: none"> 1. Connect the cables. 2. Refer to the wiring schematic. 3. Check for voltage between the solenoid valve terminal and ground while the ignition switch is on and the controller is in the Wing In position. If voltage is present, replace the valve or valve coil.
The plow wings do not extend or retract.	<ol style="list-style-type: none"> 1. If the status light on the plow module is green but not blinking, the controller is not communicating correctly. 2. If the status light on the plow module is orange, the plow module may be wired incorrectly. 3. If the status light on the plow module is blinking orange or red, there is a problem with the module driver. 4. If the status light on the plow module is off, the plow module is not getting power. 	<ol style="list-style-type: none"> 1. Check the controller connections. Replace the controller if it is broken. 2. Refer to the wiring diagram included with your <i>Owner's Manual</i>. 3. Check the module connections for shorts. Replace the module if it is broken. 4. Check that the controller is on and that all of the plugs are connected.
The wing(s) retract too easily while plowing.	<ol style="list-style-type: none"> 1. The pressure-relief valve pressure is set too low. 	<ol style="list-style-type: none"> 1. See an authorized BOSS dealer for pressure-relief-valve adjustment.
The blade digs into the ground in the V position.	<ol style="list-style-type: none"> 1. The bumper stop is not in the correct position. 2. The pushbeam is installed too high. 	<ol style="list-style-type: none"> 1. Adjust the bumper-stop position. 2. Lower the pushbeam.
The blade does not lay flat on the ground in the scoop position.	<ol style="list-style-type: none"> 1. The bumper stop is not in the correct position. 2. The pushbeam is installed too low. 	<ol style="list-style-type: none"> 1. Adjust the bumper-stop position. 2. Raise the pushbeam. If the pushbeam is at the highest setting, adjust the bumper stop further into the center section.

Schematics

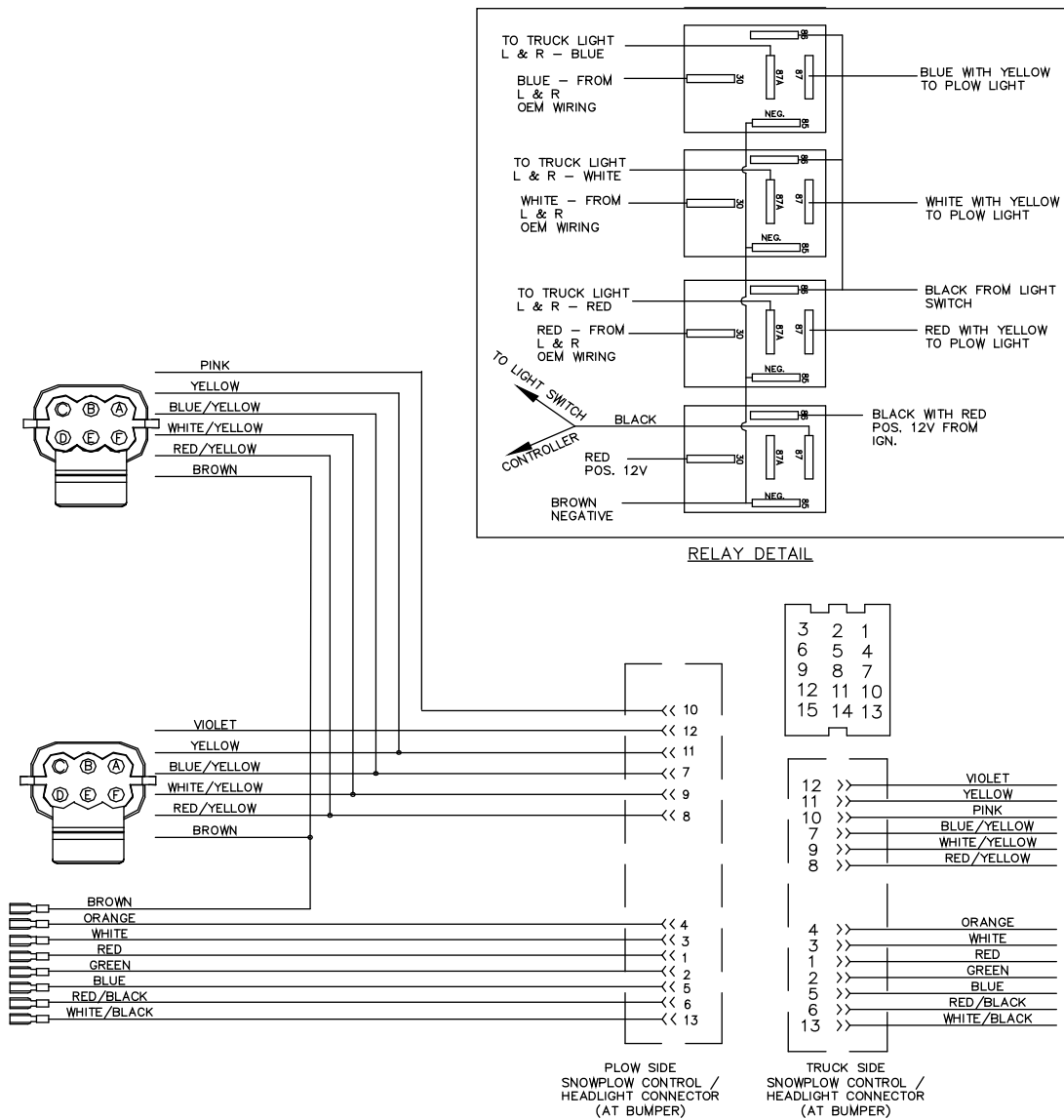

Plow Side Electrical Schematic (Rev. 0)

g272184

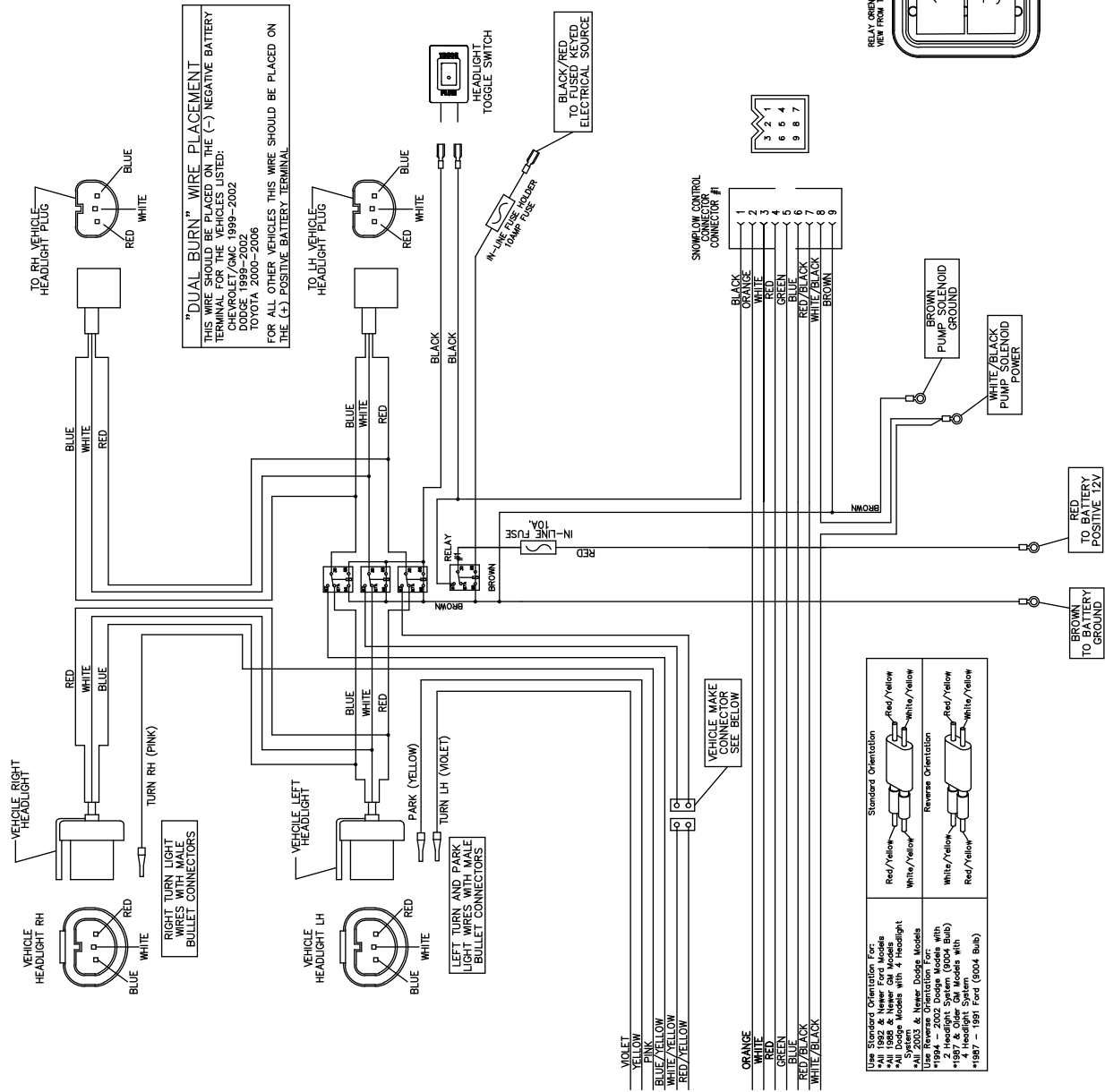

Truck Side Electrical Schematic (Rev. 0)

g272185

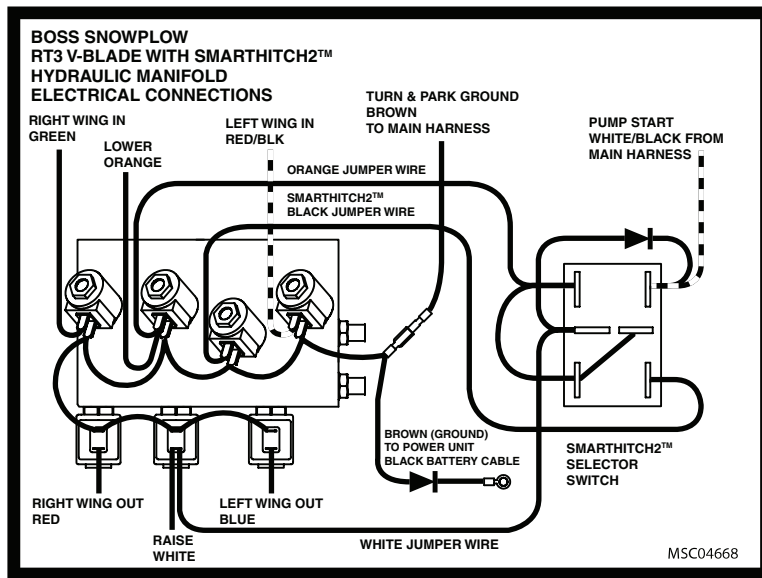

g286377

Wire Color	Function
Green	Right Wing In
Red	Right Wing Out
White	Raise
Orange	Lower
Red/Black	Left Wing In
Blue	Left Wing Out
Black	SmartHitch2
White/Black	Pump Solenoid
Brown	Ground

Hydraulic Manifold Wiring (Rev. 0)

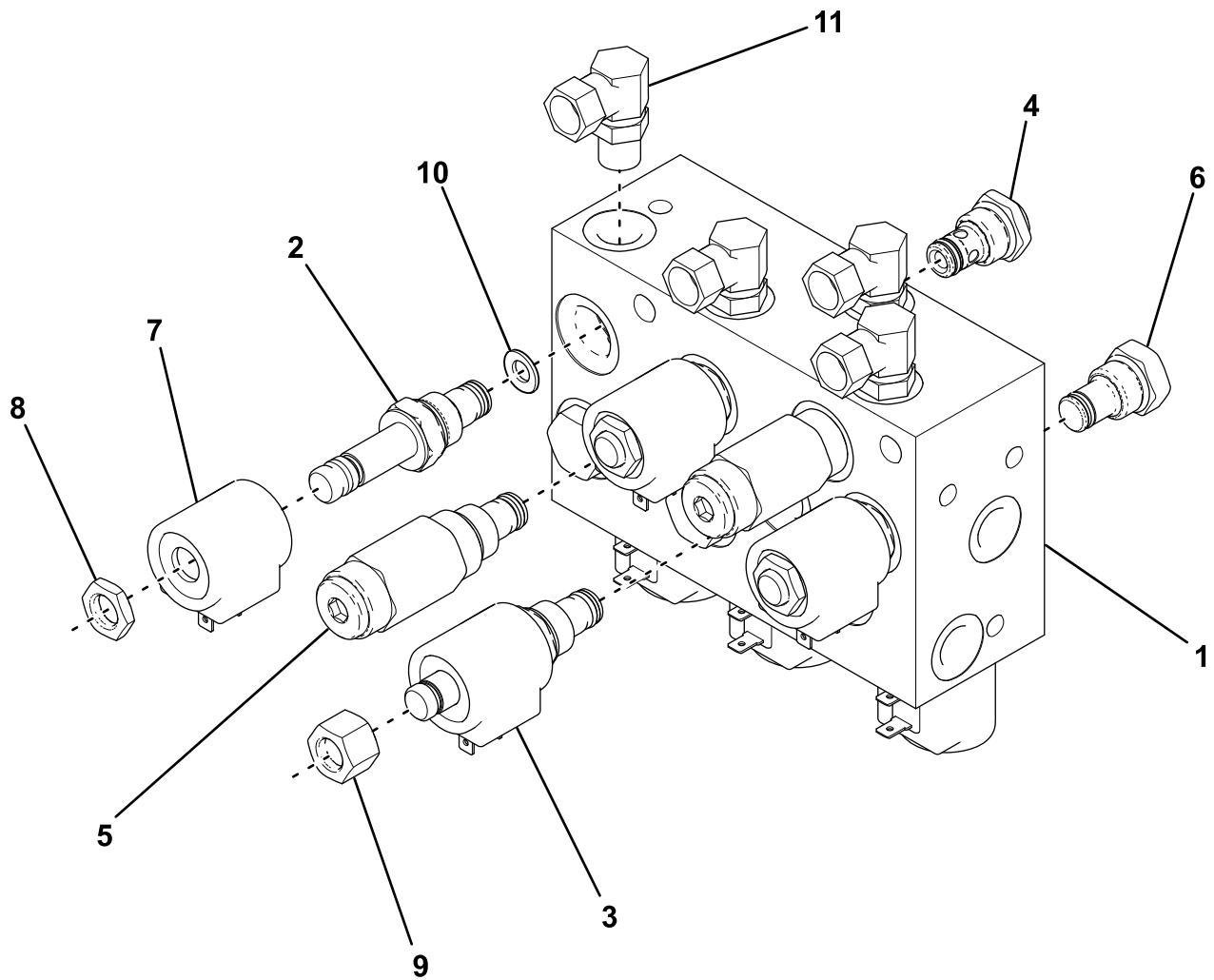

g286022

Ref.	Part Number	Qty.	Description
1	HYD07123	1	VALVE ASM, RT3, V-BL, W/ SH2, 16
2	HYD01637	6	VALVE, LIFT/ANGLE
3	HYD07047	1	VALVE, SMARTHITCH2 TM ATTACH
4	HYD07048	1	VALVE, FLOW CONTROL
5	HYD01639	2	VALVE, RELIEF V-BLADE (2800 PSI)
6	HYD01640	4	VALVE, CHECK
7	HYD01638	7	VALVE, COIL
8	HYD07059	6	COIL NUT
9	HYD07060	1	COIL NUT (SMART HITCH2 TM VALVE)
10	HYD07108	2	ORIFICE DISC, 0.08" ID
11	HYD01620	4	HYDRAULIC 90 DEG SWIVEL FITTING

Hydraulic Manifold Parts List (Rev. 0)

Notes:

BOSS
S N O W P L O W