

#### ⚠ WARNING

#### CALIFORNIA Proposition 65 Warning

This product contains a chemical or chemicals known to the State of California to cause cancer, birth defects, or reproductive harm.

## Safety

- Always follow the vehicle manufacturer's recommendations relating to system installation.
- Due to the variety of equipment that you can install using the undercarriage, ensure that the gross-vehicle-weight rating (GVWR) is not exceeded at any time. You may need to weigh the vehicle and add ballast or limit the payload of the vehicle to compensate.

## Installation

1. Park the machine on level ground, engage the parking brake, shut off the engine, and remove the key.
2. Remove the front vehicle skid plate.
3. Secure the rear of the plow skid plate to the vehicle frame bracket using 2 bolts (3/8 x 1-1/4 inch), 2 washers, and 2 locknuts (3/8 inch) as shown in [Figure 1](#).

**Note:** Torque the fasteners to 31 N·m (23 ft-lb).

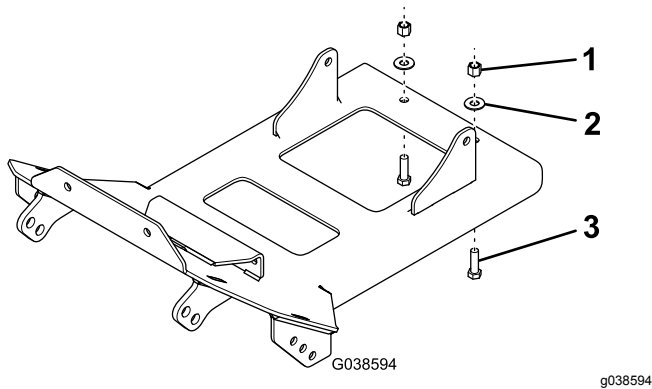

Figure 1

1. Locknut (3/8 inch)
2. Washer
3. Bolt (3/8 x 1-1/4 inch)

4. Align the cross brace bracket with the vehicle cross brace and secure it to the vehicle and plow skid plate using 4 bolts (3/8 x 1-1/4 inch) and 4 locknuts (3/8 inch) as shown in [Figure 2](#).

**Note:** Torque the fasteners to 31 N·m (23 ft-lb).

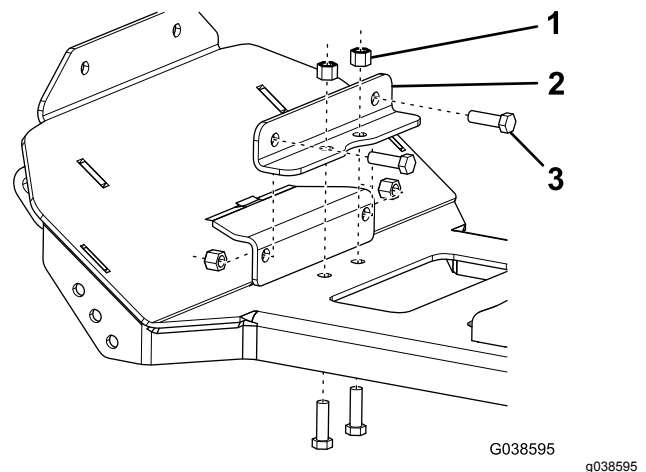
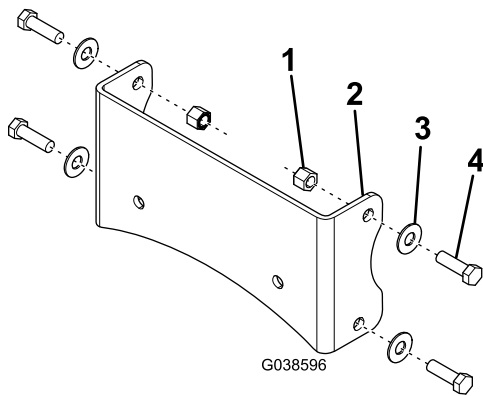

Figure 2

1. Locknut (3/8 inch)
2. Cross brace bracket
3. Bolt (3/8 x 1-1/4 inch)

5. Loosely secure the rear winch bracket to the vehicle front A-arm uprights using 4 bolts (3/8 x 1-1/4 inch), 4 washers, and 4 locknuts (3/8 inch) as shown in [Figure 3](#).

**Note:** Ensure that the curved edge of the bracket is towards the bottom.



**Figure 3**

- |                       |                            |
|-----------------------|----------------------------|
| 1. Locknut (3/8 inch) | 3. Washer                  |
| 2. Rear winch bracket | 4. Bolt (3/8 x 1-1/4 inch) |

g038596

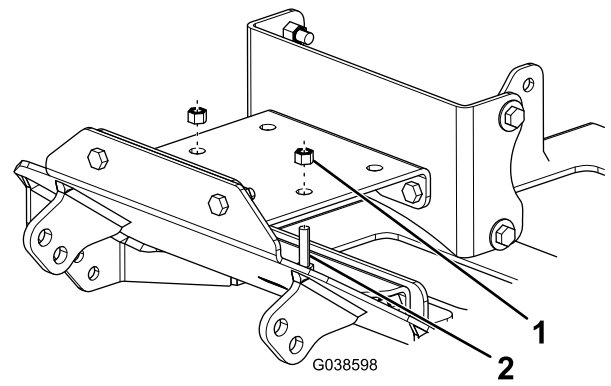
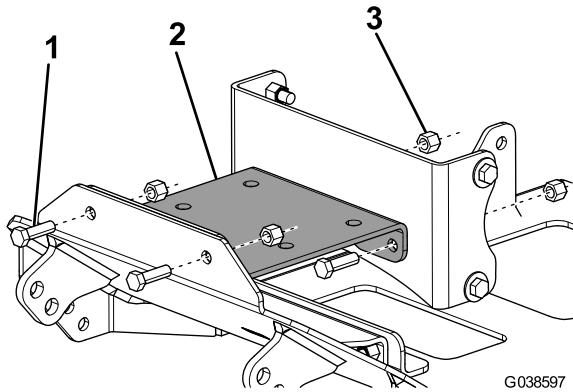

**Figure 5**

- |                        |                     |
|------------------------|---------------------|
| 1. Locknut (5/16 inch) | 2. Bolt (5/16 inch) |
|------------------------|---------------------|

g038598

6. Loosely secure the front winch bracket to the plow skid plate and rear winch bracket using 4 bolts (3/8 x 1-1/4 inch) and 4 locknuts (3/8 inch) as shown in [Figure 4](#).

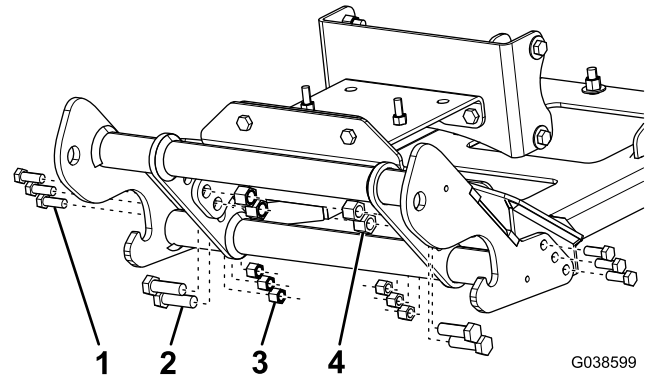

**Figure 4**

- |                            |                       |
|----------------------------|-----------------------|
| 1. Bolt (3/8 x 1-1/4 inch) | 3. Locknut (3/8 inch) |
| 2. Front winch bracket     |                       |

g038597

8. Tighten the bolts on the front and rear winch brackets and torque them to 31 N·m (23 ft-lb).
9. Mount the pushbeam to the plow skid plate using 4 bolts (1/2 inch), 4 locknuts (1/2 inch), 6 bolts (3/8 x 1 inch), and 6 locknuts (3/8 inch) as shown in [Figure 6](#).



**Figure 6**

- |                        |                       |
|------------------------|-----------------------|
| 1. Bolt (3/8 x 1 inch) | 3. Locknut (3/8 inch) |
| 2. Bolt (1/2 inch)     | 4. Locknut (1/2 inch) |

G038599

g038599

7. Secure the front winch bracket to the vehicle bumper using 2 bolts (5/16 inch) and 2 locknuts (5/16 inch) as shown in [Figure 5](#).

**Note:** Finger tighten the bolts.

10. Torque the 1/2-inch bolts to 76 N·m (56 ft-lb), and torque the 3/8-inch bolts to 31 N·m (23 ft-lb).
11. If necessary, secure the optional front plate to the plow skid plate using the existing 2 bolts (3/8 x 1-1/4 inch) and locknuts (3/8 inch) on the front winch bracket ([Figure 7](#)).

**Note:** Torque the fasteners to 31 N·m (23 ft-lb).

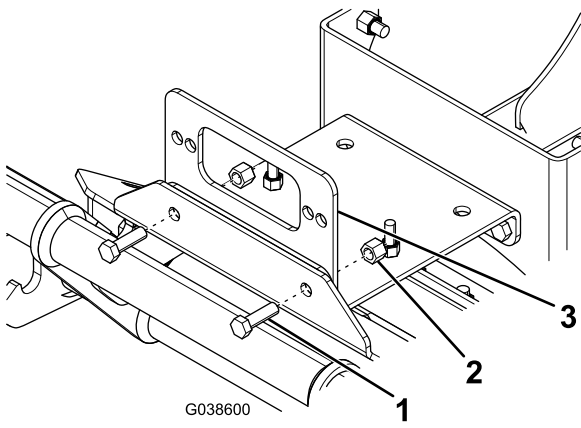

**Figure 7**

- 1. Bolt (3/8 x 1-1/4 inch)
- 2. Locknut (3/8 inch)
- 3. Front plate (optional)

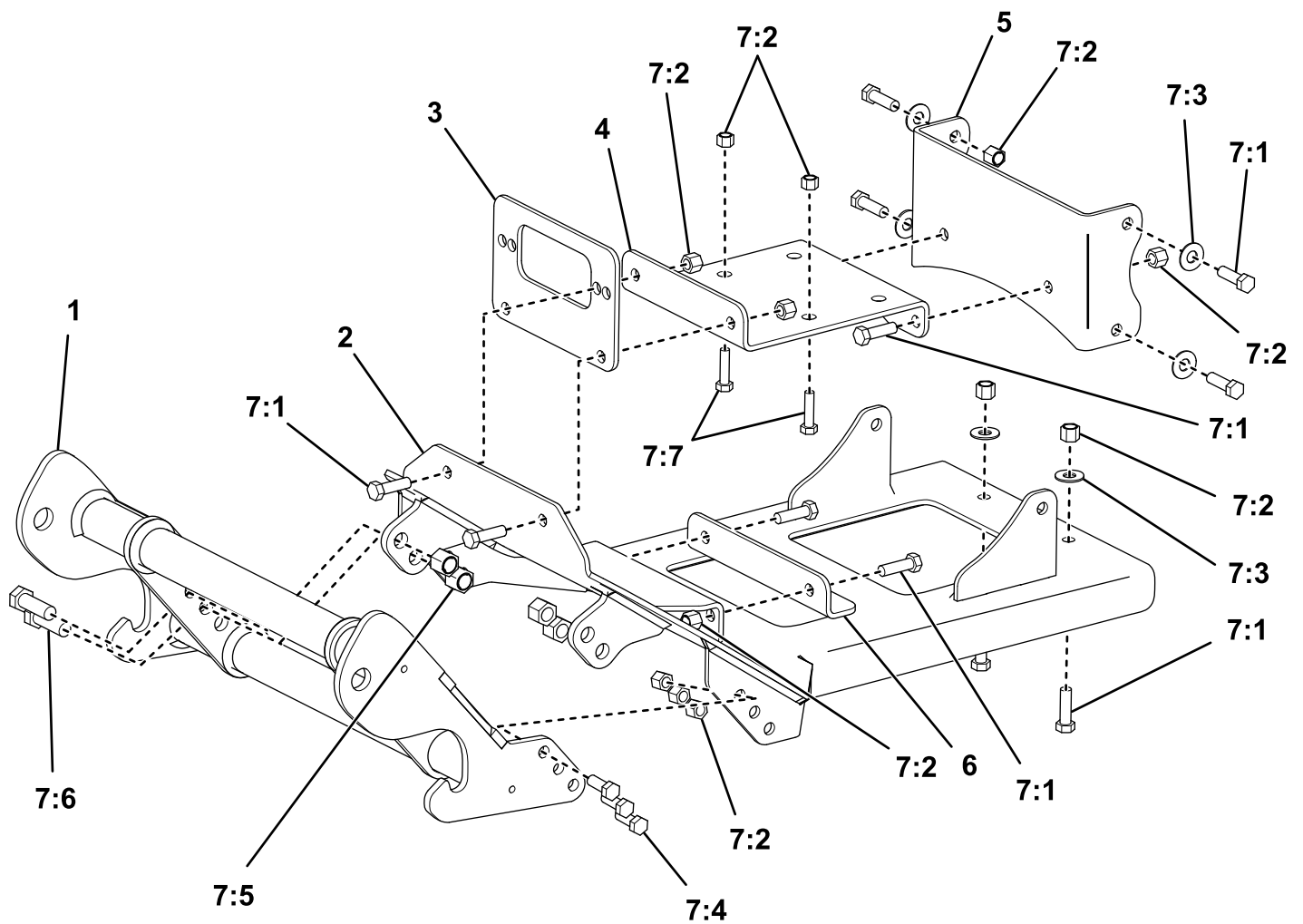

**Parts**

g214376

Ref.	Part Number	Qty.	Description	Ref.	Part Number	Qty.	Description
1	PBA12535	1	PUSHBEAM ASSEMBLY	7:4	HDW01733	8	3/8" FLAT WASHER
2	LTA12855	1	SKID PLATE ASSEMBLY, YAMAHA VIKING, 2013+	7:5	HDW01714	2	5/16"-18 NYLON LOCK NUT
3	LTA12862	1	TOP WINCH PLATE, YAMAHA VIKING, 2013+	7:6	HDW01728	4	1/2"-13 X 1-1/2" GR5 HEX HEAD BOLT
4	LTA12863	1	REAR WINCH PLATE, YAMAHA VIKING, 2013+	7:7	HDW01748	4	1/2"-13 NYLON LOCK NUT
5	LTA12864	1	FRONT BRACKET, YAMAHA VIKING, 2013+	7:8	HDW01717	6	3/8"-16 X1" GR5 HEX HEAD BOLT
6	LTA12867	1	FAIR LEAD PLATE, YAMAHA VIKING, 2013+				
7	HDW12865	1	FASTNER KIT, UC, YAMAHA VIKING, 2013+				
7:1	HDW05580	2	5/16"-18 X 1-1/4", GR5 HEX HEAD BOLT				
7:2	HDW01720	22	3/8"-16 NYLON LOCK NUT				
7:3	HDW01771	16	3/8"-16 X 1-1/4" GR5 HEX HEAD BOLT				