

SNOWPLOW

Manufactured by: **BOSS Products**
A Div. of Northern Star Industries, Inc.

906-774-0440
800-286-4155
906-779-4218 (FAX)

P.O. Box 787
Iron Mountain, MI 49801-0788
E-Mail: sales@bossplow.com
Web Site: www.bossplow.com

SNOW DEFLECTOR INSTALLATION INSTRUCTIONS MSC13099

MSC13099 Deflector Components.....Page 1

Follow the instructions that correspond to your plow.

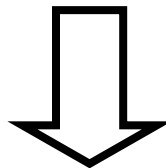

Steel Power-V XT Blade Assembly Instructions..... Page 2

BOSS Products / Northern Star Industries, Inc. reserves the right under its continuous product improvement policy to change construction or design details and furnish equipment when so altered without reference to illustrations or specifications used herein.

PUSHING THE EDGE

MSC13098-1

MSC13099 Snow Deflector Components

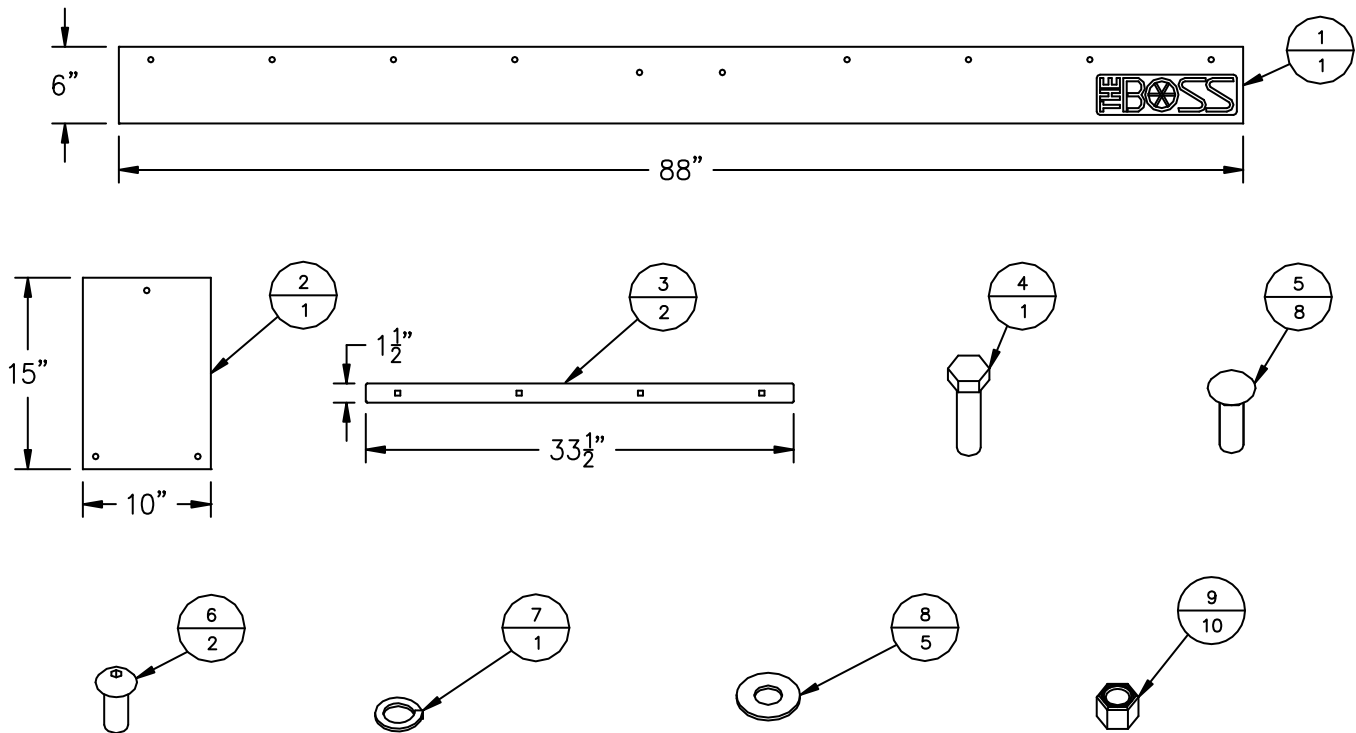

Figure 1. MSC13099 Snow Deflector and HDW13097 Fastener Kit Contents

G10622

ITEM #	QUANTITY	PART #	DESCRIPTION
1	1	MSC13072	BELTING 88" x 6"
2	1	MSC13073	BELTING, CENTER 15" x 10"
3	2	MSC13074	METAL STRAP, 1-1/2" x 33-1/2"
4	1	HDW01719	3/8 - 16 x 1-1/2" HHCS
5	8	HDW05576	3/8 - 16 x 1-1/4" CARRIAGE BOLT
6	2	HDW07502	3/8 - 16 x 1" BUTTON HEAD BOLT
7	1	HDW01718	3/8 - SPLIT LOCK WASHER
8	5	HDW01733	3/8 - FLAT WASHER
9	10	HDW01720	3/8 - 16 NYLON LOCK NUT

Note: Snow Deflector Kit MSC13099 fits only the BOSS multi-position 6'6" V-XT Snowplow.

Snow Deflector Assembly Instructions

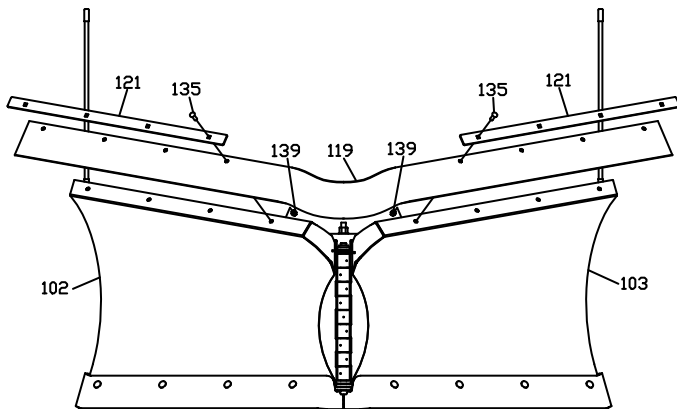

Figure 37. Snow Deflector Belting Assembly G10533

1. With the snowplow in the V position, assemble Snow Deflector 88" Belting (119) and two Snow Deflector Straps (121) to the top edge of both driver side Blade Half (103) and passenger side Blade Half (102) using eight 3/8" X 1-1/4" Carriage Bolts (135) and eight 3/8" Nylon Lock Nuts (139). When properly installed, the BOSS logo should be on the driver side of the snowplow.
2. Using one 3/8" X 1-1/2" Hex Head Cap Screw (133), one 3/8" Split Lock Washer (144), and one 3/8" Flat Fender Washer (141), secure Snow Deflector Center Flap (120) through the rear hole of Center Hinge Pin (110) and into the top of Center Section (100).

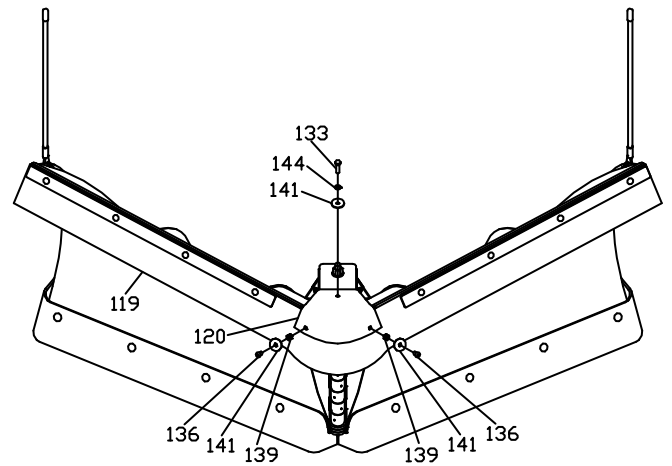

Figure 38. Snow Deflector Center Flap G10621

3. Attach Snow Deflector Center Flap (120) to the top of Snow Deflector 88" Belting (119) by using two 3/8" X 1" Button Head Screws (136) and two 3/8" Flat Fender Washers (141) on the top side and two 3/8" Flat Fender Washers (141) and two 3/8" Nylon Lock Nuts (139) on the bottom side.