

UNIVERSAL BOXFLOW COUPLER INSTALLATION INSTRUCTIONS BXP16881

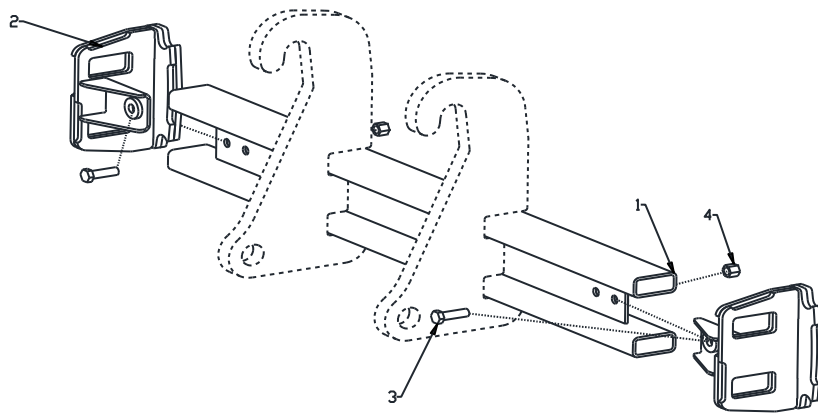

Figure 1. BXP16881 Assembly

G10936

| ITEM # | QUANTITY | PART # | DESCRIPTION |
|--------|----------|----------|------------------------------|
| 1 | 1 | BXP16882 | PUSHBEAM,ASSY,CPLR,BXP |
| 2 | 2 | BXP16883 | SLIDER,ASSY,CPLR,BXP |
| 3 | 2 | HDW05615 | HHCS,3/4-10X2-1/2 NC GR5 PLT |
| 4 | 2 | HDW03037 | NUT,3/4-10,NYL INS,YZN |

Note: Hooks shown in dotted lines are for illustrative purposes only, and are not included with the universal coupler. Users will need to source the appropriate hooks for their equipment to be welded on to the coupler. The example hooks shown are for a CAT 928 coupler.

Before welding hooks to coupler, grind off paint where joints will be welded. After welding is complete, repaint any bare metal in the welded area to help prevent rusting.

To assemble to a Boss BH12, bolt slider assemblies (2) to OUTER holes on coupler (1) using bolts (3) and nuts (4). To assemble to a Boss LDR 14/16, bolt slider assemblies (2) to INNER holes on coupler (1) using bolts (3) and nuts (4). For both BH and LDR products, slider assemblies (2) will bolt to slip-hitches as shown in the BH or LDR assembly manual.

BOSS Products / The Toro Company, Inc. reserves the right under its continuous product improvement policy to change construction or design details and furnish equipment when so altered without reference to illustrations or specifications used herein.