



P.O. Box 787 Iron Mountain, MI 49801-0787  
ISO 9001:2008 REGISTERED  
bossplow.com

# RT3 STRAIGHT BLADE WITH SMARTHITCH2™ INSTALLATION MANUAL

## TABLE OF CONTENTS

WARNINGS.....2

SNOWPLOW MOUNTING & REMOVAL PROCEDURE .....3

SNOWPLOW ASSEMBLY PROCEDURE.....4

ELECTRICAL SYSTEM WIRING PROCEDURE.....10

HEADLIGHT ADAPTER INSTALLATION PROCEDURE.....15

ELECTRICAL SYSTEM WIRING SCHEMATIC (PLOW SIDE).....16

ELECTRICAL SYSTEM WIRING SCHEMATIC (TRUCK SIDE).....17

ELECTRICAL SYSTEM WIRING DIAGRAM.....18

RT3 STRAIGHT BLADE MANIFOLD WIRING DIAGRAMS.....19

HYDRAULIC POWER UNIT FILL PROCEDURE .....20

HEADLIGHT AIMING PROCEDURE.....21

HYDRAULIC VALVE ASSEMBLY PARTS LIST.....22

STRAIGHT BLADE CONTROLLERS.....23

TROUBLESHOOTING GUIDE.....27

RECOMMENDED PUSH BEAM HEIGHT .....32

RECOMMENDED BOLT TORQUE .....32

Original Instructions

BOSS PRODUCTS reserves the right under its continuous product improvement policy to change construction or design details and furnish equipment when so altered without reference to illustrations or specifications used herein.

Patent: [www.tcopatents.com](http://www.tcopatents.com)

**DRIVEN TO BE THE BEST**

STB03278-17

## **WARNING**

Serious injury or death can result if you do not follow these instructions and procedures which are outlined further within your owner's manual

- Read this manual carefully before operating this snowplow.
- Many newer trucks are equipped with air bags. DO NOT under any circumstances disable, remove or relocate any sensors or other components related to the operation of the air bags.
- Always follow the vehicle manufacturer's recommendations relating to snowplow installation. For recommended vehicle models refer to the BOSS Snowplow Application Chart and Selection Guide.
- Vehicles equipped with air bags are designed such that the air bags will be activated in a frontal collision equivalent to hitting a solid barrier (such as a wall) at approximately 14 mph or more, or, roughly speaking, a frontal perpendicular collision with a parked car or truck of similar size at approximately 28 mph or more. Careless or high speed driving while plowing snow, which results in vehicle decelerations equivalent to or greater than the air bag deployment threshold described above, would deploy the air bag.
- When transporting, position plow so as not to reduce visibility or block plow headlights.
- DO NOT change blade position when traveling.
- DO NOT exceed 40 mph when transporting plow.
- DO NOT exceed 14 mph when plowing.
- Always lower blade when vehicle is not in use.
- Make sure plow is properly attached before moving vehicle.
- Never place any part of your body under the snowplow at any time. Doing so may cause bodily harm and/or death.
- Wear proper personal protection equipment when operating and servicing snowplow; including, but not limited to, clothing for cold weather and slippery surfaces.
- Refer to vehicle manufacturer's Owner's Manual for proper driving and parking procedures including any specific procedures that related to snowplows.
- To comply with Federal Regulations and to assure a safe vehicle, the Front Gross Axle Weight Rating (FGAWR), Rear Gross Axle Weight Rating (RGAWR), and the Gross Vehicle Weight Rating (GAWR) must not be exceeded at any time.
- Due to the variety of equipment that can be installed on this vehicle, it is necessary to verify that the Front Gross Axle Weight Rating (FGAWR), Rear Gross Axle Weight Rating (RGAWR), and the Gross Vehicle Weight Rating (GAWR) are not exceeded at any time. This may require weighing the vehicle and adding ballast as necessary. It may also limit payload capacity of the vehicle. It is the operator's responsibility to verify that these ratings are not exceeded.
- Some snowplow components are very heavy – use properly rigged 1/2-ton minimum lifting device to maneuver heavy snowplow components.
- Snowplow operating noise level below 70dB.
- MSDS are available at [www.bosspow.com](http://www.bosspow.com).
- Hydraulic component installation and maintenance must be performed by trained personnel.
- Never place body parts between snowplow and vehicle.
- When transporting be sure to properly secure your load. Proper load securing instructions are available at [www.bosspow.com](http://www.bosspow.com).

BOSS RT3 SNOWPLOW

### STRAIGHT-BLADE SNOWPLOW MOUNTING PROCEDURE

#### STEP 1

#### STEP 2

- Place the snowplow control in the **FLOAT** position.
- Line up the vehicle with the snowplow and drive straight in until the lower pin contacts the push beam pin receiver.
- Turn levers to the **ON** position. Remove the electrical plug dust covers. Connect the electrical plugs.

- Push the SmartHitch 2 switch upward to raise the coupler tower until the spring pins snap in.
- Check that both spring pins have fully engaged the coupler. Move the coupler tower to align spring pins with the pin receiver holes until both pins engage completely.
- Release the SmartHitch 2 to stop movement of the coupler tower. Pull the kickstand spring pin outward and raise the kickstand. Release the kickstand spring pin to secure in the raised position.
- Turn truck/plow toggle switch to plow position.

---

### STRAIGHT-BLADE SNOWPLOW REMOVAL PROCEDURE

#### STEP 1

#### STEP 2

- Turn truck/plow toggle switch to truck position.
- Place the snowplow control in the **FLOAT** position. Pull the kickstand spring pin to release and lower the kickstand.
- Turn the levers to the **OFF** position.
- Push the SmartHitch 2 switch upward to raise the coupler tower and release the coupler spring pins.

- Push the SmartHitch 2 switch downward until the coupler tower completely lowers to the plow.
- Disconnect the electrical plugs and install the electrical plug dust covers.
- Back the vehicle away from the snowplow slowly.

MSC06354

Figure 1. Mounting Procedures

# Snowplow Assembly Procedure

**Note:** This manual is used for the assembly of all Standard, Super, and Heavy-Duty BOSS Straight Blade Plows. Part numbers and illustrations may vary.

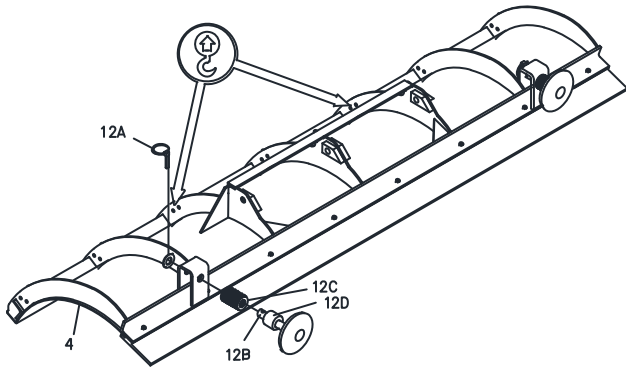
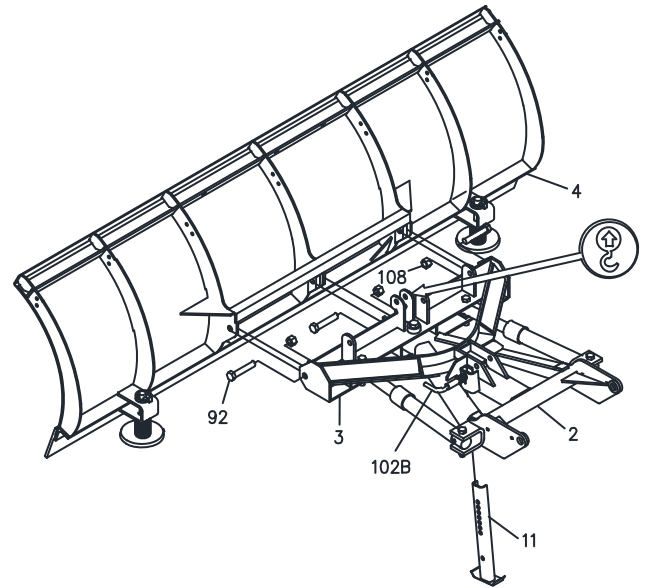

**Figure 2.** Shoe Assembly

G10059

1. Begin the assembly procedure by cutting down each corner of the plow box so that each wall of the box will lie flat on the floor. The box can be used as a mat and will help prevent scratching the blade during installation.
2. Place Plow Blade (4) face down on the box.
3. Install Cast Shoe Assembly (12). Mount Plow Shoes (12B) on Blade Assembly (4) using 1-1/2" Spacer (12D) and 1" Flat Washers (12C) on the bottom and top of the shoe. Secure with 7/16" Quick Pins (12A).

**Note:** In general, plow shoes should be mounted flush with the bottom of the cutting edge when the plow is mounted on the truck to be used for plowing. When plowing on a solid level area (parking lots, roads, and driveways) plow shoes can be raised up to increase cutting edge contact on the plowed surface. When plowing dirt, gravel, or grass plow shoes should be lowered below the cutting edge surface to prevent the plow from digging into the plowed surface.

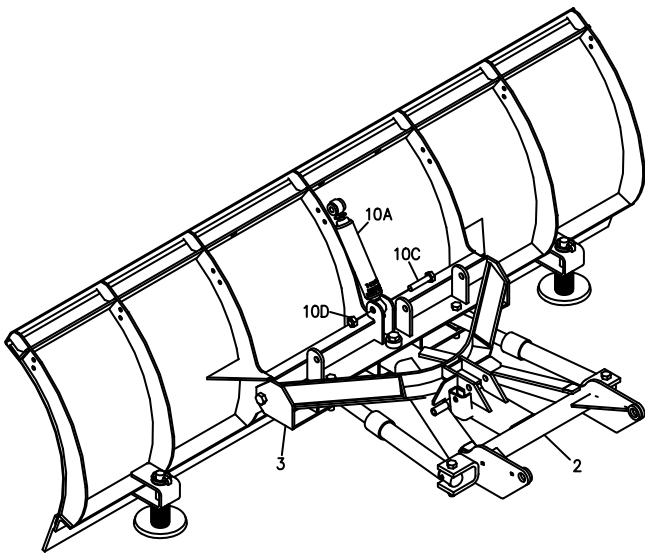

**Figure 3.** Push Frame Attachment

G10060

4. Attach Push Frame Attachment Bar (3) to Plow Blade (4) using three 3/4"-10 x 4" Hex Head Cap Screws (92) and three 3/4"-10 Self-Locking Nuts (108).
- Note:** The Heavy-Duty Straight Blade is attached to the Push Frame Attachment Bar with four bolts.
5. Pull the Kickstand Spring Pin (102B) outward then insert Kickstand Leg (11) through the kickstand mount bracket. Release Kickstand Spring Pin (102B) to lock Kickstand Leg (11) in place.

## Snowplow Assembly Procedure



**Figure 4.** Shock Mount Attachment G10061

**Note:** Shock Absorber Option Kit (10) is standard on all Super-Duty Straight Blade Plows. It is optional for all other straight blade plows.

**Note:** The Heavy-Duty Straight Blade has two Shock Absorbers.

6. Mount Shock Absorber (10A) on Push Frame Attachment Bar (3). Insert the base end of Shock Absorber (10A) between the mounting tabs on Push Frame Attachment Bar (3).

**Note:** The base end of Shock Absorber (10A) is the end that has the BOSS logo and part number engraved.

7. Insert 5/8"-11 x 3" Hex Head Cap Screw (10C) through the mounting tabs and the base end of Shock Absorber (10A). The head of Hex Head Cap Screw (10C) must be on the right side of the mount as illustrated in Figure 4. Install 5/8"-11 Oval Top Lock Nut (10D) on 5/8"-11 x 3" Hex Head Cap Screw (10C) and leave finger tight.

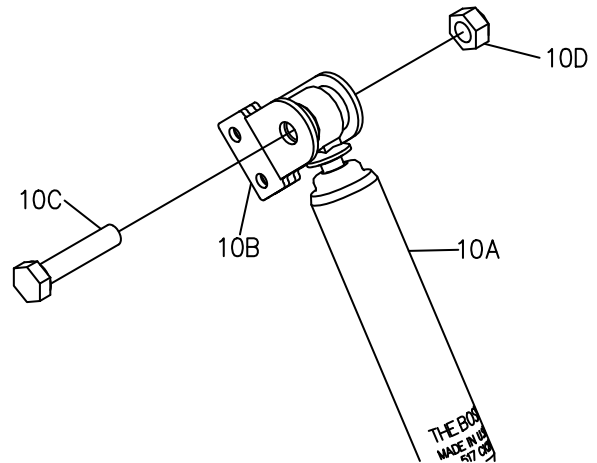

**Figure 5.** Shock Mounts to Shock Absorber G10062

8. Install Blade Shock Mounts (10B) to the rod end of Shock Absorber (10A) using 5/8"-11 x 3" Hex Head Cap Screw (10C) and 5/8"-11 Oval Top Lock Nut (10D). Leave the mount finger tight.

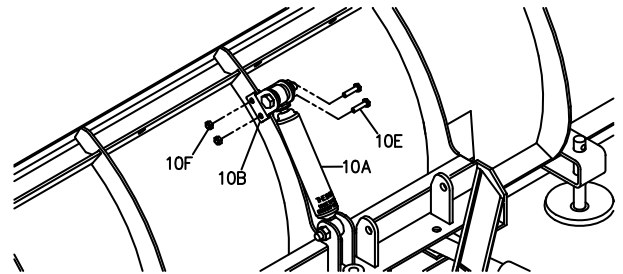

**Figure 6.** Shock Mounts to Plow Blade G10063

9. Align the small holes in Blade Shock Mounts (10B) with the holes in the center rib of the snowplow as shown in Figure 6. You must have one Blade Shock Mount (10B) on each side of the center rib. Attach with two 3/8"-16 x 1 1/2" Hex Head Cap Screws (10E) and two 3/8"-16 Nylon Lock Nuts (10F). Leave the hardware finger tight.

## Snowplow Assembly Procedure

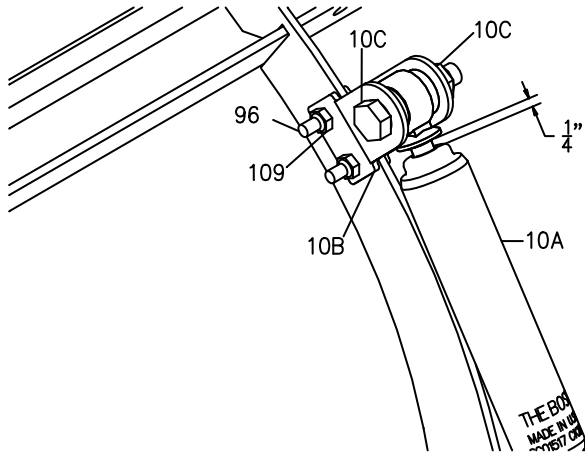

Figure 7. Tightening the Hardware

G10064

10. Before tightening the hardware, it is advised that you extend Shock Absorber (10A) to reveal approximately 1/4" of the rod. This will prevent Shock Absorber (10A) from bottoming out when the blade swings back after tripping. Keeping the shock extended, fully tighten 3/8"-16 x 1 1/2" Hex Head Cap Screws (96) and 3/8"-16 Nylon Lock Nuts (109).
11. Tighten both 5/8"-11 x 3" Hex Head Cap Screws (10C) and both 5/8"-11 Oval Top Lock Nuts (10D) while holding Shock Absorber (10A) in place. Do not over-tighten these bolts as it may cause damage to Shock Absorber (10A). 5/8"-11 x 3" Hex Head Cap Screws (10C) should have no more than 1/2" of thread showing beyond the nut after you have tightened them.

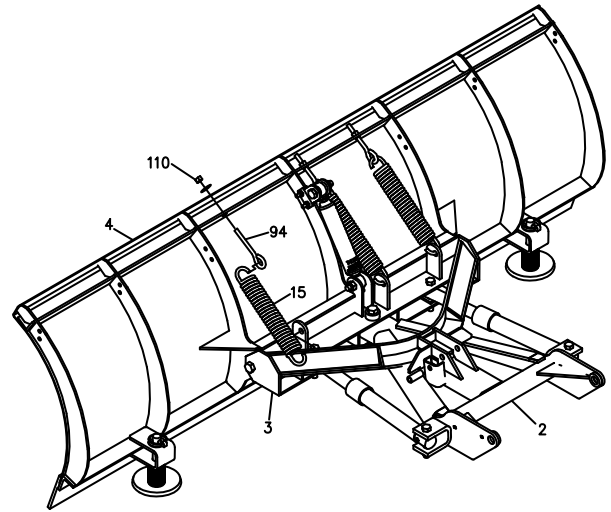

Figure 8. Trip Spring Assembly

G10065

12. Insert Trip Spring (15) through the holes provided on Push Frame Attachment Bar (3).
13. Attach Eye Bolt (94) around the loose end of Trip Spring (15).
14. Insert the threaded end of Spade Bolt (94) through the hole in the spring mounting brackets on the back of Blade Assembly (4). Secure Spade Bolts (94) using 1/2" flat washer and Self Locking Nut (110). Tighten Self-Locking Nuts (110) until the coils on Trip Springs (15) are approximately 1/32" apart.

**Note:** The Standard Duty Steel Snowplow uses three Trip Springs and 5/8" Spade Bolts. Standard Duty Poly Snowplow uses three Trip Springs and 1/2" Spade Bolts. Super Duty Snowplows use four Trip Springs and 1/2" Spade Bolts. Heavy-Duty Straight Blade uses six Trip Springs and 1/2" Spade Bolts. All the Hardware differences are noted in the exploded view posters.

## Snowplow Assembly Procedure

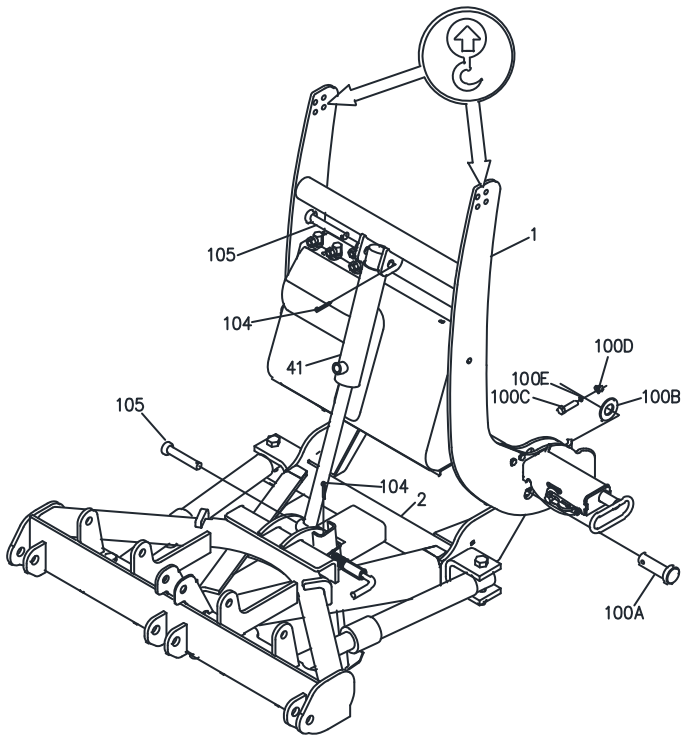

**Figure 9.** Lift Cylinder Installation

G10127

15. Position the rod end of Lift Cylinder (41) between the cylinder mounts of Push Frame Assembly (2). Insert 5/8" x 3 1/2" Clevis Pin (105) through the cylinder mounts and secure with #16 Hairpin Cotter (104).

**Note:** Heavy-Duty plows use 3/4" x 3 3/4" Clevis Pin (105).

16. Align the pivot holes of Coupler Assembly (1) with the pivot holes of Push Frame Assembly (2).

17. Insert 1" X 3" Pivot Pin (100A) through Coupler Assembly (1) and Push Frame (3). Secure with 1" Flat Washer (100B), 3/8"-16X1-3/4" Hex Head Cap Screw (100C), 3/8" Flat Washer (100E) and 3/8"-16 Nyl Lock Nut (100D).

**Note:** Heavy-Duty plows use 1 1/2" Pivot Pin and 5/16" hardware in place of 3/8" hardware.

18. Rotate Lift Cylinder (41) up to the cylinder mounts located on Coupler Tower Assembly (1). Insert 5/8" x 3 1/2" Clevis Pin (105) through the cylinder mounts and secure with #16 Hair Pin Cotter (104).

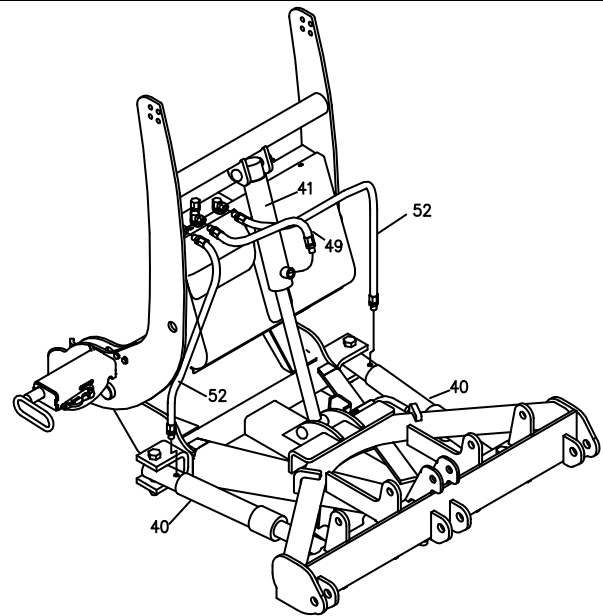

**Figure 10.** Hydraulic Connections

G10128

19. Install Hydraulic Hose (49) between the middle fitting on the hydraulic shelf and the lower port of Lift Cylinder (41). Tighten both ends of the hose securely.

20. Install Hydraulic Hose (52) between the left fitting on the hydraulic shelf and the port of the Left Angle Cylinder (40). Apply thread compound at the hose to cylinder connection. Tighten both ends of the hose securely.

**Note:** Heavy-Duty plows use Hydraulic Hose (52).

21. Repeat step 19 for the Right Angle Cylinder Hose.

## Snowplow Assembly Procedure

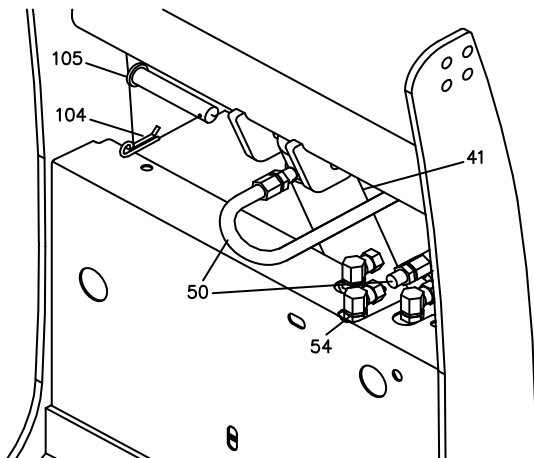

**Figure 11.** Connecting Hose G10120

22. Remove the plug from the top end of Lift Cylinder (41).
23. Attach one end of Hydraulic Hose (50) to top end of Lift Cylinder (41). Thread compound should be used. Tighten connection securely.
24. Create an "S" shape with Hydraulic Hose (50) and connect the loose end to the rear Hydraulic Fitting (54). Tighten connection securely.

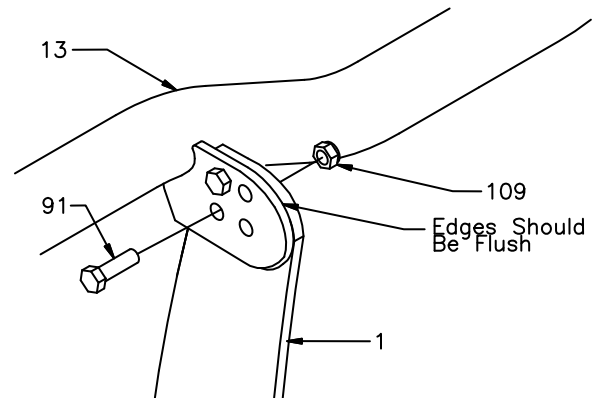

**Figure 12.** Light Bar Assembly (Standard) G10132

25. Attach Light Bar (13) to the top of Coupler Assembly (1) using two 3/8"-13 x 1 1/4" Hex Head Cap Screws (91) and 3/8"-13 Nylon Locking Nuts (109).

**Note:** The light bar should be positioned as close to the Coupler Tower as possible. Only two holes will be aligned for normal installations. Only two bolts per side are needed to secure the light bar.

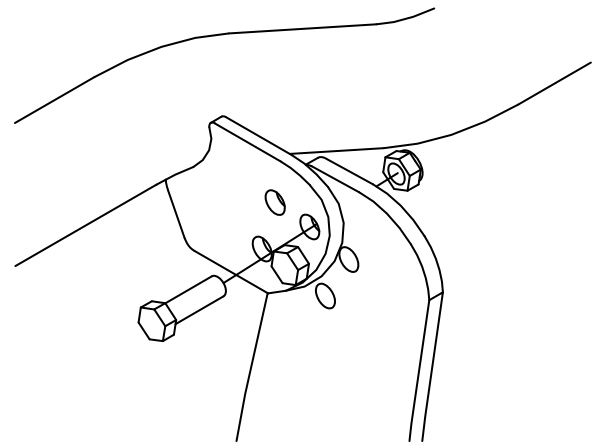
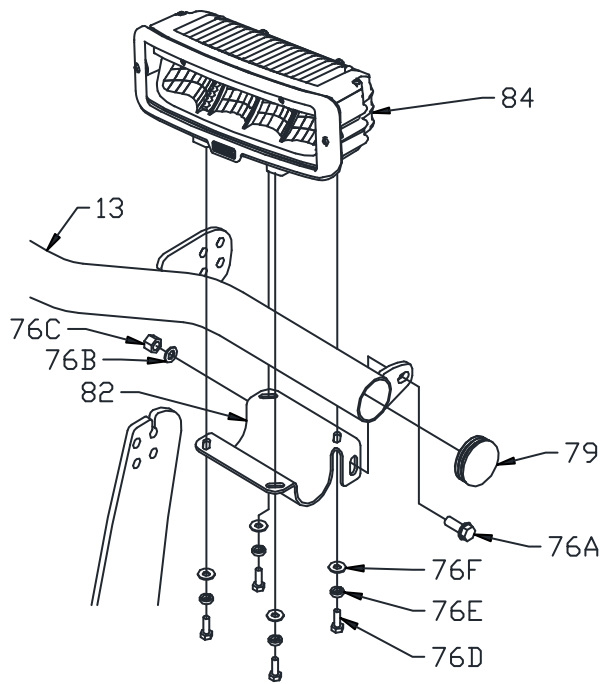

**Figure 13.** Light Bar Assembly Adjustment G10131

**Note:** Figure 13 illustrates that the Coupler Assembly and Light Bar have two sets of 1 inch adjustment holes for mounting on different vehicles. These adjustment holes may be needed in order to move the light bar away from the vehicle's hood.



## Snowplow Assembly Procedure



**Figure 14.** Headlight Mounting Assembly G10115

26. Check that End Cap (79) is properly inserted into Light Bar (13).
27. Place Driver Side Headlight Bracket (82) below Light Bar (13) and secure with one 3/8"-16 X 1" Hex Head Shoulder Bolt (76A), one 3/8" Flat Washer (76B), and one 3/8" Nylon Lock Nut (76C).
28. Fasten Driver Side Headlight (84) to Driver Side Headlight Bracket (82) using four 1/4"-20 X 3/4" Hex Head Bolts (76D), four 1/4" Split Lock Washers (76E), and four 1/4" Flat Washers (76F). Leave fasteners finger tight until Headlight orientation has been completed. See Figure 14 for proper fastener placement. **Torque to 6 ft-lbs. DO NOT USE THREAD-LOCKING COMPOUND.**
29. Repeat Steps 26 through 28 for Passenger Side Headlight Bracket (83) and Passenger Side Headlight (85).

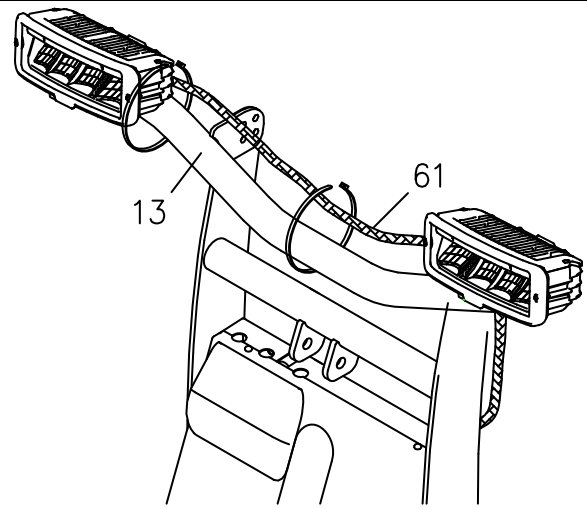

**Figure 15.** Securing Wiring Harness G10126

30. Secure Wiring Harness (61) to Light Bar (13) using wire ties as shown above.
31. Attach headlight connectors to headlight bulbs by inserting the connectors up through the bottom of the headlight housings.

**Note:** See Headlight Aiming Procedure within this manual for proper adjustment of the headlights.

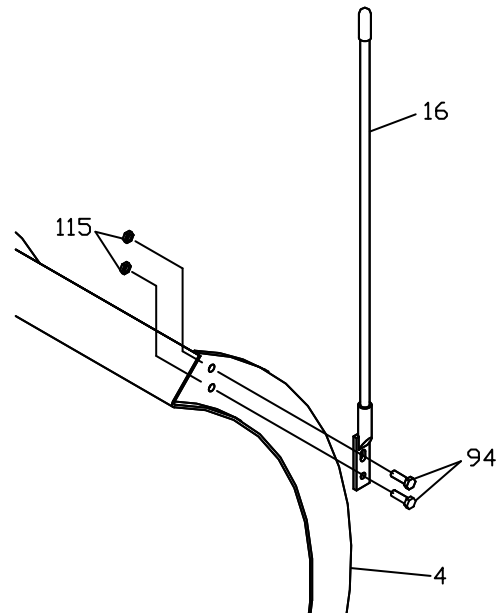

**Figure 16.** Assembly of Blade Guides G10071

32. Attach Blade Guides (16) to Blade Assembly (4) using 5/16"-16 x 1" Hex Head Cap Screws (94) and 5/16"-16 Nylon Locking Nuts (115).

## Electrical System Wiring Procedure

### **! WARNING**

Before starting any Electrical Wiring Procedure make sure that the engine is not running and that the engine has had sufficient time to cool down. Failure to do so may result in serious bodily injury or death.

### **! WARNING**

Before starting any Electrical Wiring Procedure make sure to disconnect the battery. Failure to do so may result in serious bodily injury or death.

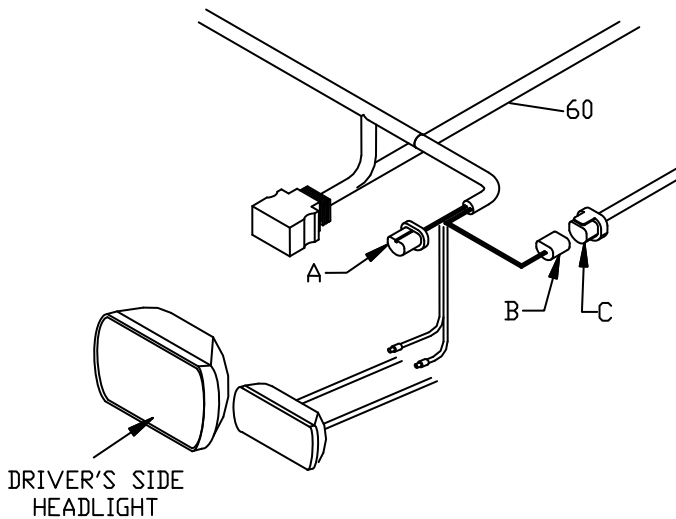

Figure 17. Driver Side Headlight

G10140

**Note:** Dielectric grease should be applied to all electrical connections.

1. Disconnect the driver side headlight connector plug (C) from the back of the driver's side vehicle headlight.
2. Connect the Blue Sealed Beam Connector (A) from Wiring Harness (60) into the back of the driver side vehicle headlight.
3. Connect the Black Rubber Connector (B) from Wiring Harness (60) into the OEM Wiring Harness (C). OEM Wiring Harness (C) is the vehicle connector that was unplugged from the back of the headlight in Step 1.

**Note:** If your connectors do not match the connectors on the wiring harness or you have a four-headlight system a Headlight Adapter Kit will be needed. If you are installing a Headlight Adapter Kit, See "Headlight Adapter Installation Procedure" located in this manual.

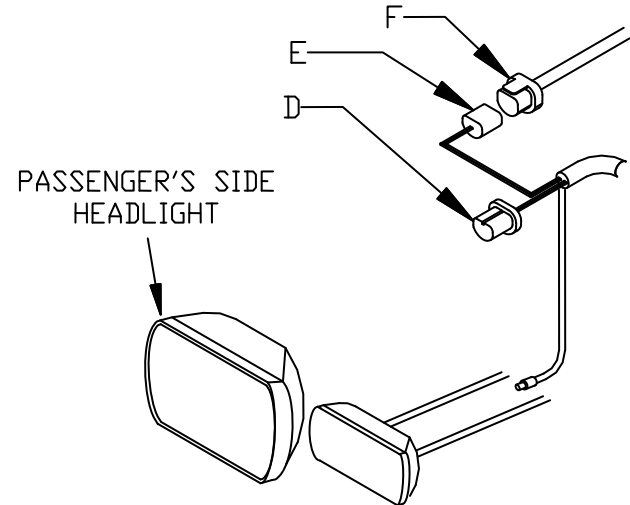

Figure 18. Passenger Side Headlight

G10141

4. Disconnect the passenger side OEM Wiring Harness (F) from the back of the passenger's side vehicle headlight.
5. Connect the Blue Sealed Beam Connector (D) from Wiring Harness (60) into the back of the passenger side vehicle headlight.
6. Connect the Black Rubber Connector (E) from Wiring Harness (60) into the OEM Wiring Harness (F). OEM Wiring Harness (F) is the vehicle connector that was unplugged from the back of the headlight in Step 4.

## NOTICE

Before splicing into any electrical circuit, identify the circuit with a test lamp. Failure to test circuits may result in vehicle damage. Be sure the wire loom does not interfere with the operation of the vehicle's pedals.

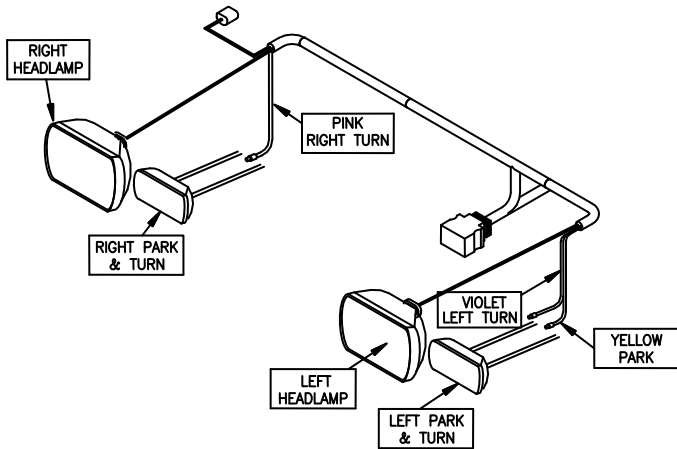

**Figure 19.** Connecting Park and Turn G10143

**Note:** Some trucks require a turn signal relay kit.

7. Connect the PINK wire from Wiring Harness (60) to the passenger side turn signal wire. Use the splice connector provided to you in the hardware kit.
8. Connect the VIOLET wire from Wiring Harness (60) to the driver side turn signal wire. Use the splice connector provided to you in the hardware kit.
9. Connect the YELLOW wire from Wiring Harness (60) to the driver side park light wire. Use the splice connector provided to you in the hardware kit.

**Note:** Be sure that the firewall is clear of obstructions before drilling in Step 10.

10. Drill a 1-1/4" diameter hole through the firewall. The hole should be located on the driver side, in an easily accessible area.

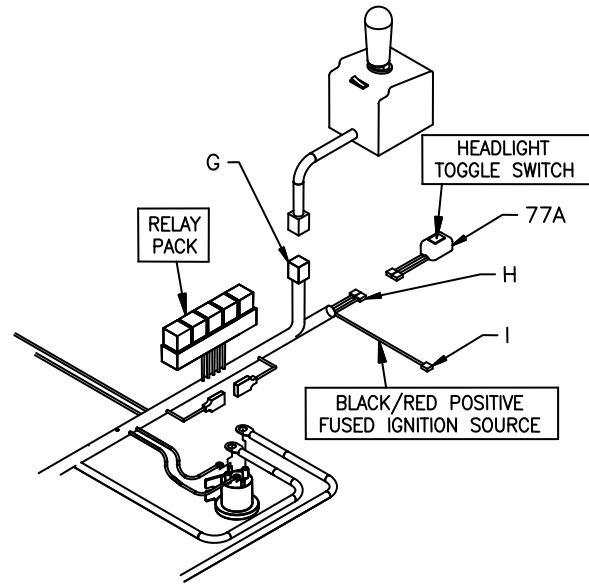

**Figure 20.** Internal Cab Wires G10144

11. Pull the two BLACK wires (H), BLACK/RED wire (I), and the 9 Pin Molex connector (G) from the engine compartment into the cab through the 1-1/4" diameter hole in the firewall.
12. Install Split Rubber Grommet (Not Shown) into the hole that was cut in the firewall.
13. Connect the Two Tab Connectors (H) to Headlight Toggle Switch (77A) as illustrated in the figure above.

## NOTICE

All plow wiring should be secured under the hood in a position that provides sufficient room so that hot or moving parts will not be contacted. Vehicle damage could occur if wires are not properly secured.

14. Choose an area of the vehicle's dashboard for the light toggle switch to be mounted. Clean the area thoroughly. Allow the area to dry completely.
15. Remove the adhesive backing and apply the switch to the clean area of the dashboard. Apply pressure for 30 seconds.

## Electrical System Wiring Procedure

16. Secure the 9 Pin Molex Connector (G) and wire loom underneath the dashboard.
17. Plug the controller into the 9 Pin Molex Connector (G).
18. Mount the plow control in a location that is comfortable for the operator to reach, and where the operator will not contact the control in the event of a crash. (See "Straight Blade Controller Mounting Instructions" located in this manual.)
19. Connect the BLACK/RED wire (I) to a "keyed" 12V+ ignition source.

**Note:** This 12V+ source should only be active when the key is in the ON position. Failure to wire to a "keyed" source can allow a condition to occur causing the battery to drain.

**Note:** Location of the wires on the small terminals does not matter but the wires should not be on the same terminal.

22. Attach Power Unit Solenoid (64) securely inside the engine compartment. The Power Unit Solenoid should be mounted in the upright position as illustrated in Figure 24.

**Note:** The solenoid must be installed so that the solenoid posts do not contact the body, hood, or any other conductive material on the vehicle.

23. Attach the eyelet end of RED Power/Ground Cable (62) to the top of Pump Solenoid (64).
24. Connect Battery Cable (66) to the top post of Pump Solenoid (64).

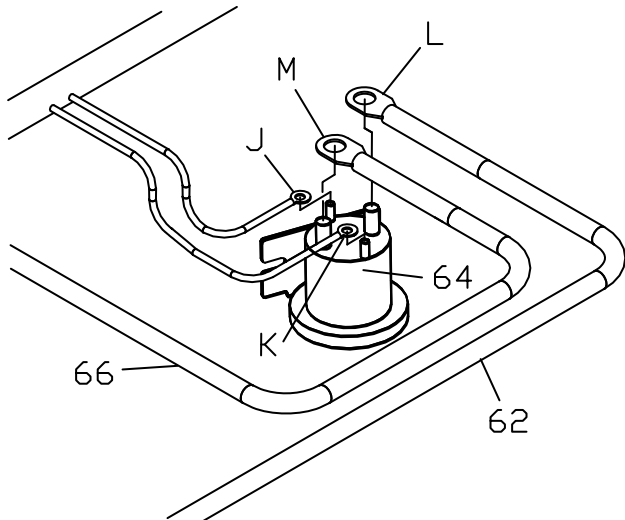

Figure 21. Solenoid Connections.

G10145

20. Connect the WHITE/BLACK wire (J) of Wiring Harness (60) to the small terminal on Pump Solenoid (64).
21. Connect the BROWN wire (K) of Wiring Harness (60) to the small terminal on Pump Solenoid (64).

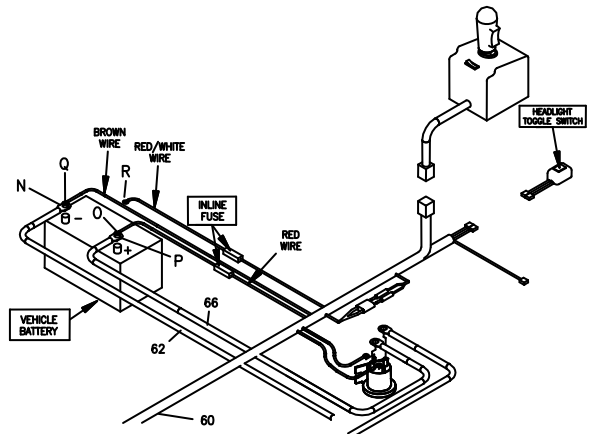
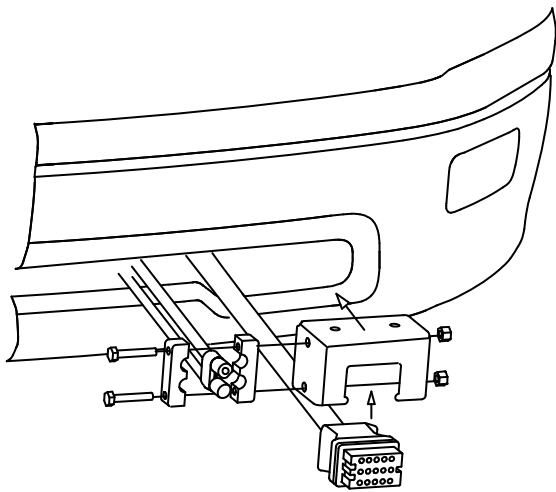

Figure 22. Battery Connections

G10146

25. Attach the eyelet end (N) of BLACK Power/Ground Cable (62) to the negative battery terminal.
26. Connect the BROWN wire (Q) to the negative battery terminal.
27. Connect the unattached end (P) of Battery Cable (66) to the positive battery terminal.
28. Connect the RED Fused wire (O) to the positive battery terminal.

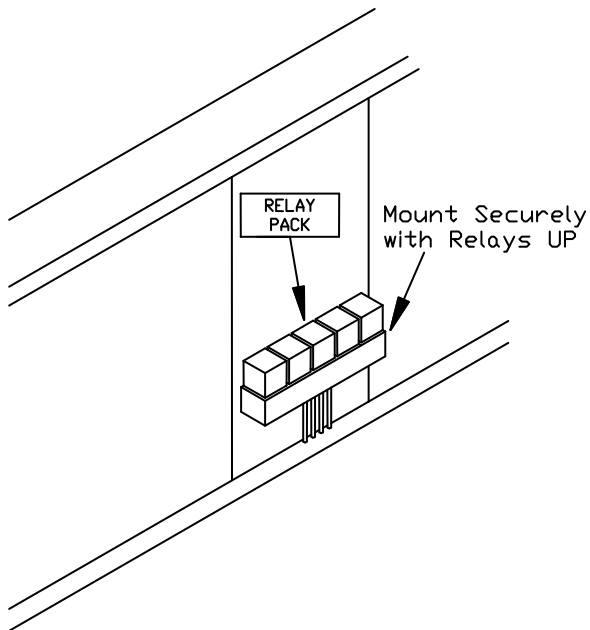

**Figure 23.** Vehicle Connections G10148

29. Mount the Black 15 Pin Control Harness Connector to the lower area of the bumper using Control Harness Mounting Bracket.
30. Mount the BLACK and RED 2 Pin Power Ground Connector to the lower area of the bumper using Power Ground Mounting Bracket.

**Note:** Installation location will vary depending on truck.

---



**Figure 24.** Relay Mounting. G10152

31. Attach the Relay Pack securely to the inside of the engine compartment using four Sheet Metal Screws. The relays should be positioned upright as illustrated above.

## Electrical System Wiring Procedure

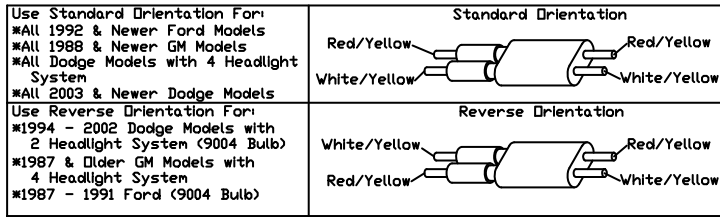

**Figure 25.** Vehicle Option Connector G10202

32. Locate vehicle option connector. Align the connector so that the arrow on the Vehicle Option Connector is positioned to match the vehicle it is installed on. This is illustrated in Figure 25.

**Note:** If your vehicle is not listed in the above figure use the Standard Orientation. If the Vehicle Option Connector is not properly connected the lights on the plow will not function correctly.

"DUAL BURN" WIRE PLACEMENT
THIS WIRE SHOULD BE PLACED ON THE (-) NEGATIVE BATTERY TERMINAL FOR THE VEHICLES LISTED: CHEVROLET/GMC 1999-2002 DODGE 1999-2002 TOYOTA 2000-2006
FOR ALL OTHER VEHICLES THIS WIRE SHOULD BE PLACED ON THE (+) POSITIVE BATTERY TERMINAL

**Figure 26.** RED/WHITE Wire Placement G10522

**Note:** Connection of RED/WHITE wire (R) is dependent on the grounding system of the vehicle that it is installed on. If the placement of RED/WHITE wire (R) is not correct the Low Beam bulb will not be illuminated when Plow Lights are on High Beam.

33. Connect RED/WHITE wire (R) to the correct battery terminal for your vehicle. See Figure 26 for proper placement for your vehicle.

34. Secure all plow harness wiring.

35. Attach the snowplow to the vehicle. Use the "Snowplow Mounting Procedure" that is located in this manual to properly attach the snowplow to the vehicle.

36. Test for the proper operation of the Headlight Wiring Harness. Follow the procedures below.

**Note:** To test plow lights, the **IGNITION** must be in the **ON** position.

- **LOW BEAM (Truck Lights)**
  - ◆ Vehicle Headlight Switch – ON
  - ◆ Low Beam Lights on Truck Indicator
  - ◆ Plow Headlight Toggle Switch –TRUCK

**RESULTS** - Only vehicle low beam headlights should be illuminated.

- **HIGH BEAM (Truck Lights)**
  - ◆ Vehicle Headlight Switch – ON
  - ◆ High Beam Indicator Light – ON
  - ◆ Plow Headlight Toggle Switch –TRUCK

**RESULTS** - Only vehicle high beam headlights should be illuminated.

- **LOW BEAM (Plow Lights)**
  - ◆ Ignition - ON
  - ◆ Vehicle Headlight Switch – ON
  - ◆ Low Beam Lights on Truck Indicator
  - ◆ Plow Headlight Toggle Switch - PLOW

**RESULTS** - Only plow low beam headlights should be illuminated.

- **HIGH BEAM (Plow Lights)**
  - ◆ Ignition - ON
  - ◆ Vehicle Headlight Switch – ON
  - ◆ High Beam Indicator Light – ON
  - ◆ Plow Headlight Toggle Switch – PLOW

**RESULTS** - Both plow high beam and low beam headlights should be illuminated.

- **TURN SIGNALS (Plow and Truck)**
  - ◆ Left Turn Signal Indicator – ON

**RESULTS** - Both Left Plow and Left Truck turn signal bulbs should be flashing.

- ◆ Right Turn Signal Indicator – ON

**RESULTS** - Both Right Plow and Right Truck turn signal bulbs should be flashing.

- **PARK LIGHTS (Plow and Truck)**
  - ◆ Park Lights on Vehicle – ON

**RESULTS** - All Four, Left Plow, Right Plow, Left Truck, and Right Truck Park Lights should be on.

**Note:** If any of the lights are not working properly, re-check the wiring against the "Electrical Wiring Diagram" located in this manual and make any necessary corrections.

### Headlight Adapter Installation Procedure

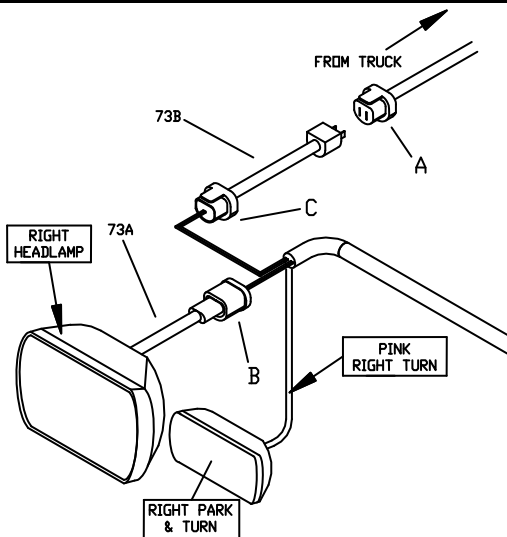

**Figure 27.** Single Headlight Adapter Connections G10149

**Note:** This is a general diagram for most 2-headlight vehicles. All vehicles and headlight adapters may not be identical. Installation will be very similar.

1. Disconnect the OEM Headlight Connector Plug (A) from the back of the vehicle headlight.
2. Connect one end of Headlight Adapter (73A) into the back of the vehicle headlight.
3. Connect the Black Rubber Female Socket (B) of Headlight Adapter (73A) into the plow wiring harness.
4. Connect the Blue Sealed Beam Connector (C) of Headlight Adapter (73B) into the plow wiring harness.
5. Connect the opposite end of Headlight Adapter (73B) into the OEM Headlight Connector Plug (A).
6. Repeat Steps 1 through 5 for the opposite side headlight.

**Note:** In some older vehicles it is not necessary to pull power from both sides of the headlights. In this case only three adapters will be needed. Follow the Headlight Adapter Installation Instructions that are packaged with the Headlight Adapter Kit.

7. Continue with Step 7 of “Electrical System Wiring Procedure” located in this manual.

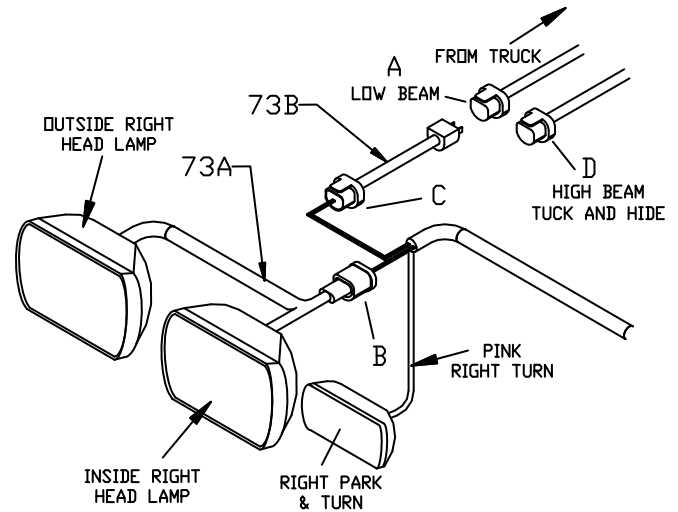

**Figure 28.** Dual Headlight Adapter Connections G10151

**Note:** This is a general diagram for most 4-headlight vehicles. All vehicles and headlight adapters may not be identical. Installation will be very similar.

1. Disconnect OEM Headlight Connector Plugs (A and D) from the back of the vehicle headlight.
2. Connect two ends of Headlight Adapter (73A) into the back of the vehicle headlights.
3. Connect the Black Rubber Female Socket (B) of Headlight Adapter (73A) into the plow wiring harness.
4. Connect the Blue Sealed Beam Connector (C) of Headlight Adapter (73B) into the plow wiring harness.
5. Connect the opposite end of Headlight Adapter (73B) into the OEM Wiring Harness (A).
6. Grease, tuck, and secure OEM Connector Plug (D). This connector is not used.
7. Repeat Steps 1 through 6 for the opposite side headlight.
8. Continue with the Step 7 of “Electrical System Wiring Procedure” located in this manual.

# Electrical System Wiring Schematic (Plow Side)

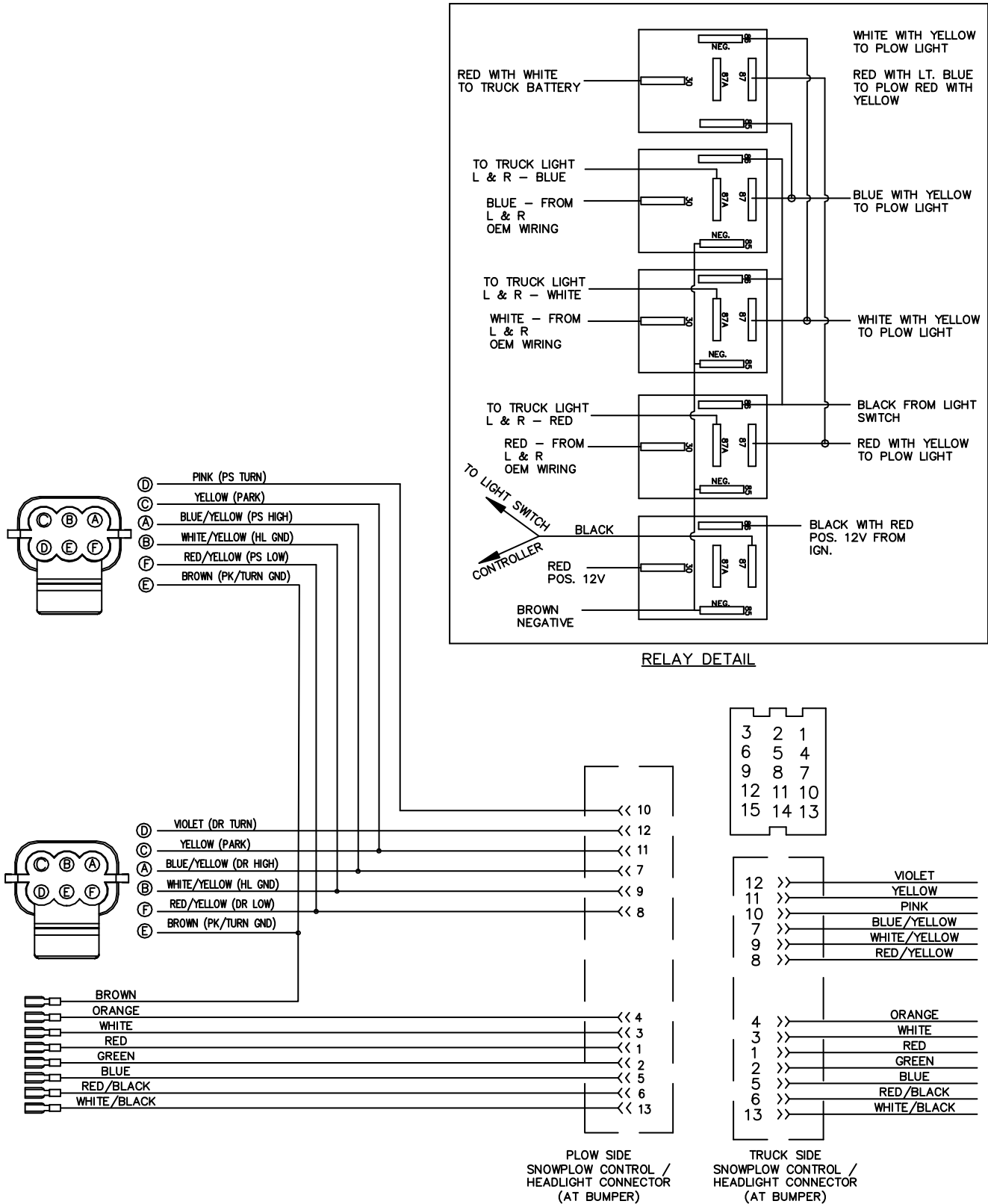

Figure 29. Electrical System Wiring Schematic (Plow Side)

G10271



# Electrical System Wiring Schematic (Truck Side)

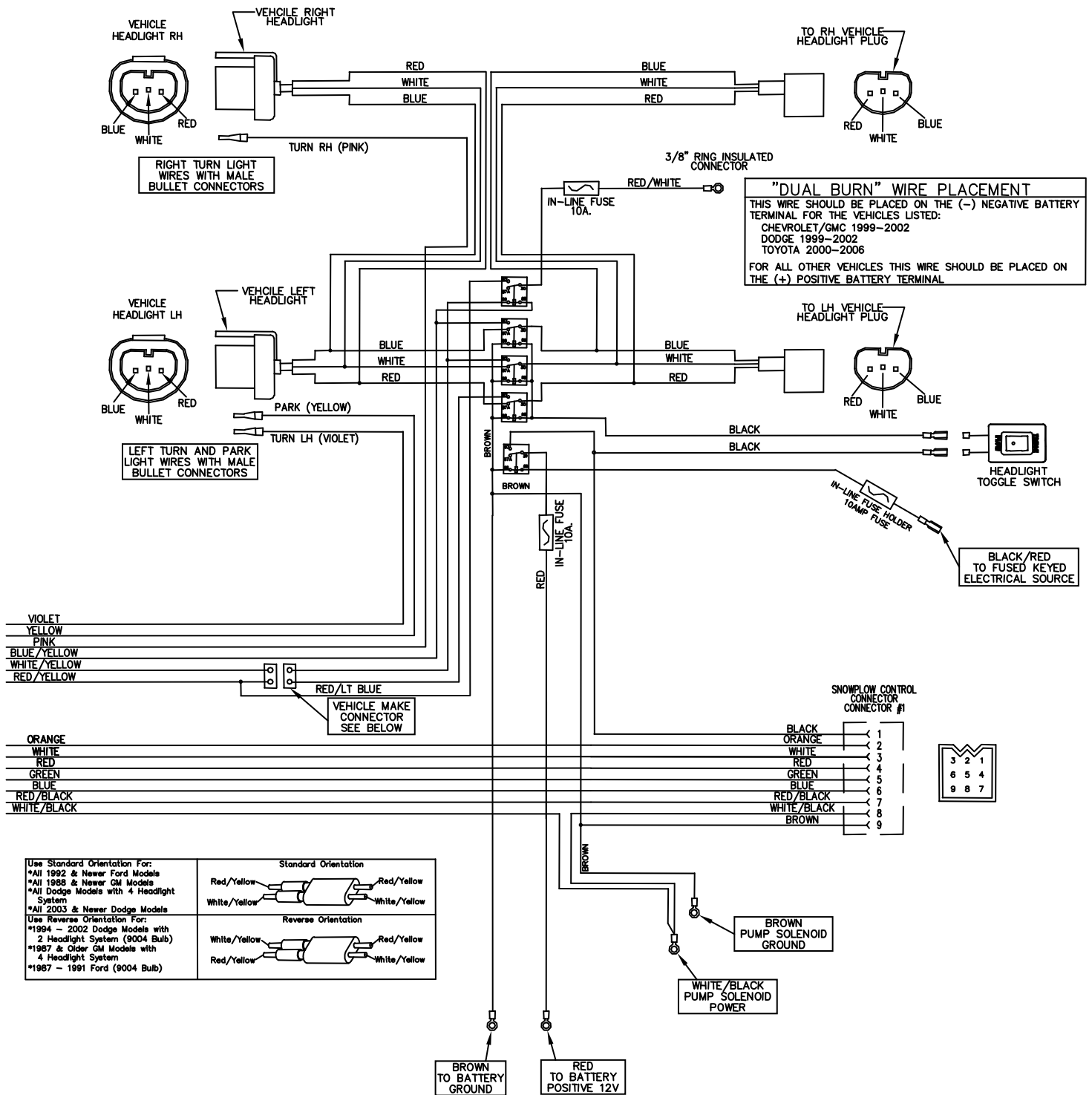

Figure 30. Electrical System Wiring Schematic (Truck Side)

G10272

# Electrical System Wiring Diagram

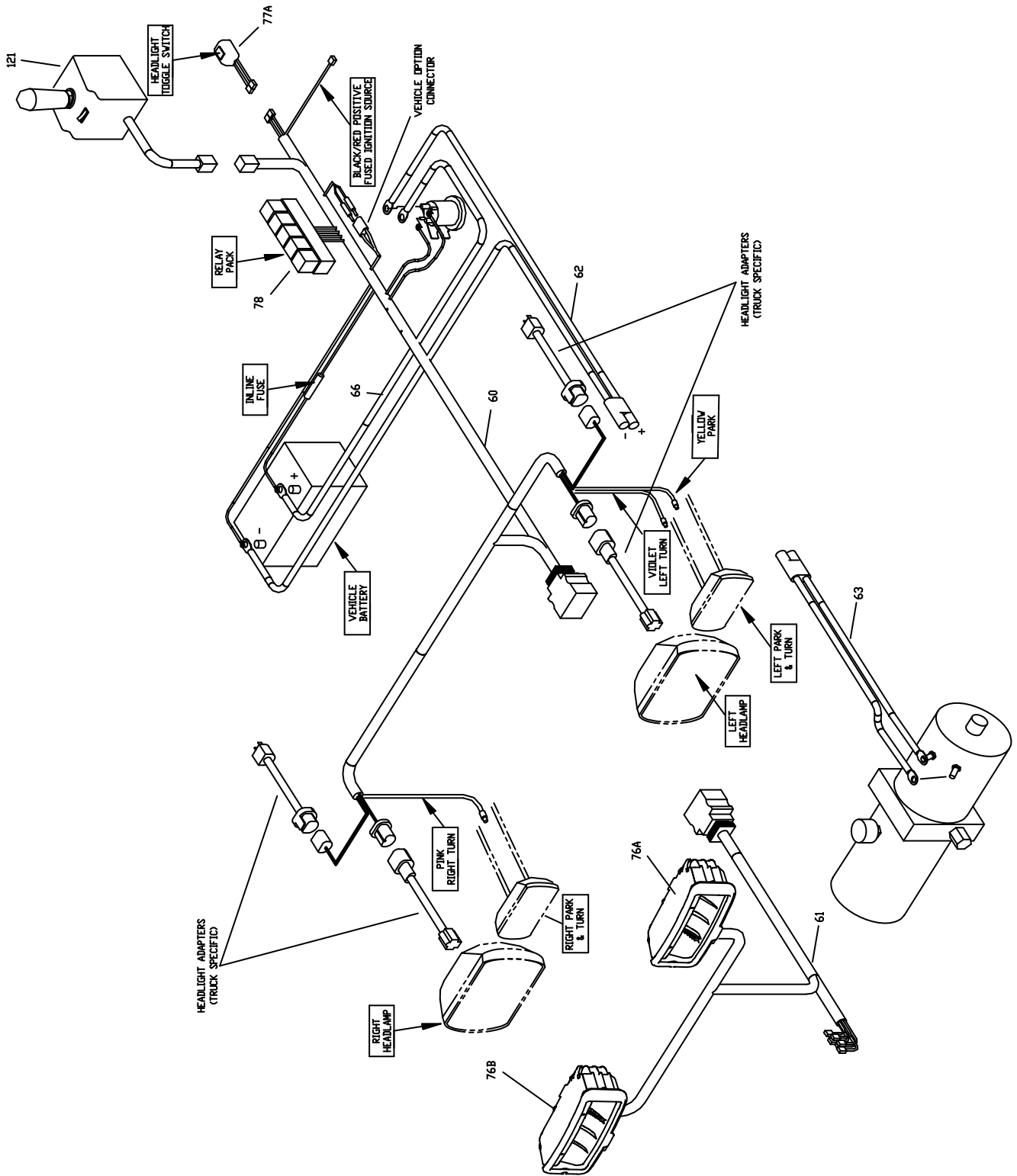

Figure 31. Electrical System Wiring Diagram

G10134

## RT3 Straight Blade Manifold Wiring Diagrams

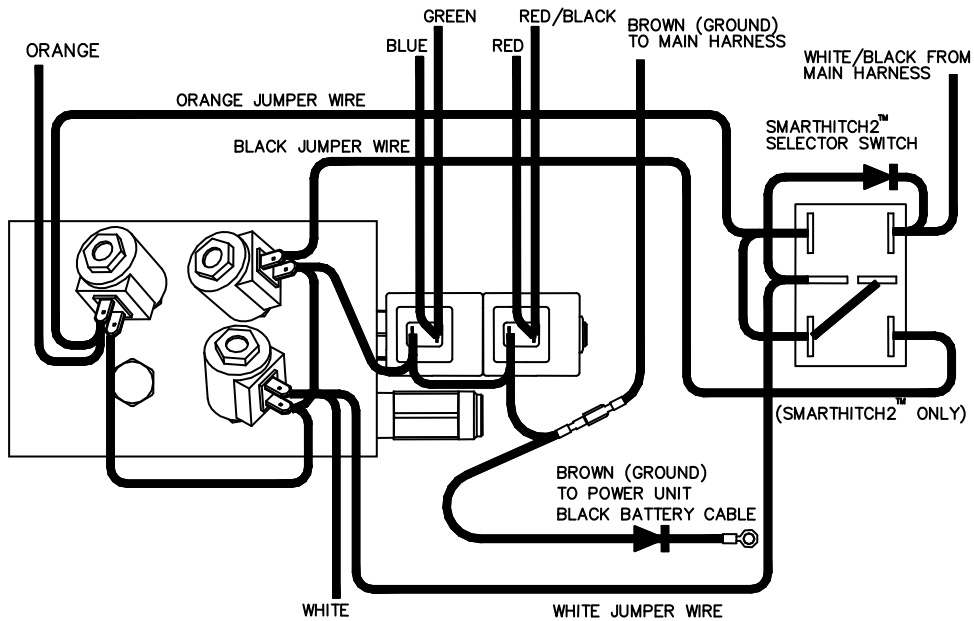

Figure 32. HYD07091 Super Duty Manifold Wiring Diagram

G10447

Wire Color	Wire Function
Green	Blade Left
Red	Blade Right
White	Lift
Orange	Lower
Red/Black	Blade Right
Blue	Blade Left
Black	SmartHitch2™ (12V)
Brown	Ground

## Hydraulic Power Unit Fill Procedure

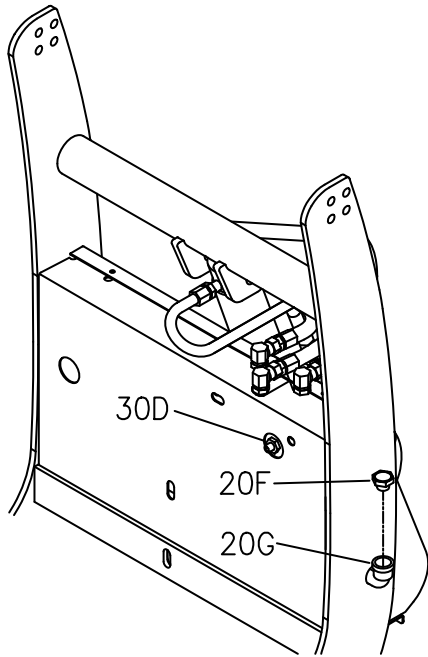

Figure 33. External Fill – Backside View G10124

Step 1 of the following fill procedure is intended for a new plow with an empty hydraulic system.

**Initial Plow Position:** Start with the plow unattached from the vehicle and the lift cylinder completely collapsed. The light tower will be tilted forwarded.

1. Remove Fill Cap (20F) from Street Elbow (20G) and fill with BOSS High Performance Hydraulic Fluid. Continue to fill Street Elbow (20G) until no more fluid will be accepted. (Approx. 2 quarts).
2. Attach the plow to the vehicle.

**Note:** If your plow is equipped with SmartHitch2™ you must hydraulically power the light tower up. Do not manually push the tower up. Failure to hydraulically power the light tower up will create an air pocket in the hydraulic system. Oil will spill out of the internal breather cap.

3. Raise the plow.
4. With the plow in the raised position, cycle through both angle functions several times.
5. Lower the plow to the ground.

**Note:** If your plow will not lower, Flow Control Valve (30D) is completely closed. Refer to Step 7 to adjust Flow Control Valve (30D).

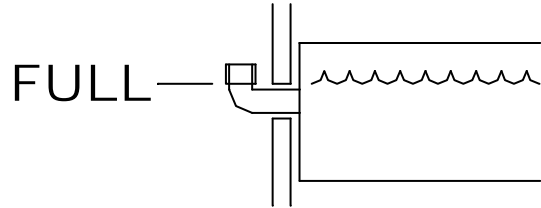

Figure 34. Oil Full Level G10411

**Plow Position to Check Oil:** The plow should be attached to the truck, sitting flat on the ground, with the blade in the straight position.

6. With the blade in the straight position and the plow lowered to the ground, check the fluid level. Fluid should be visible in the external fill port. If fluid is not visible, fill until visible. Your reservoir should now be properly filled.

**Note:** Hydraulic fluid should be replaced annually with BOSS Snowplow High Performance Hydraulic Fluid.

**Note:** If your plow is equipped with SmartHitch2™ you must hydraulically power the light tower down. Do not manually pull the light tower down. Failure to hydraulically power the light tower down will create an air pocket in the hydraulic system. Oil will spill out of the breather filler cap.

### ⚠ WARNING

When adjusting Flow Control Valve (30D) make sure all appendages are clear of the plow blade and observers are standing a safe distance away from the plow blade. The plow may drop if your controller is in the FLOAT position. Make sure your controller is in the OFF position before attempting to adjust the plow. Failure to do so may result in serious bodily injury or death.

**Note:** Flow Control Valve (30D) is not available on Green colored Hydraulic Manifolds used on Standard Duty and Sport Duty snowplows.

7. Adjust Flow Control Valve (30D) to obtain the speed desired for lowering the plow by loosening the jam nut, then adjusting the set screw. Counter-clockwise adjustment will increase the speed the plow descends. Retighten the jam nut when the desired speed is obtained.

## Headlight Aiming Procedure

### NOTICE

The installer of these snowplow lights must certify that installation conforms to applicable Federal Motor Vehicle Safety Standards.

1. Place the vehicle on a level surface 25 feet in front of a matte-white screen, such as a garage door. The screen should be perpendicular to both the ground and the vehicle.
2. Verify that the mounted headlights do not exceed a height of 54 inches from the ground to the center of the lights.
3. The vehicle should be equipped for normal operation. The snowplow blade should be in place and in the raised position.
4. Below are some points listed by the Society of Automotive engineers (SAE) pertinent to headlight aiming. These points can be found in publication #SAEJ5991D.

#### Preparation for Headlight Aim or Inspection

Before checking beam aim, the inspector shall:

- Remove ice or mud from under fenders.
- See that no tire is noticeably deflated.
- Check vehicle springs for sag or broken leaves.
- See that there is no load in the vehicle other than the driver.
- Check functioning of any "level-ride" controls.
- Clean lenses and aiming pads.
- Check for bulb burnout, broken mechanical aiming pads, and proper beam switching.
- Stabilize suspension by rocking vehicle sideways.

5. Mark (or tape) the vehicle centerline of the headlights and the vehicle itself on the screen. Mark the horizontal centerline of the headlights on the screen (distance from ground to headlight centers).

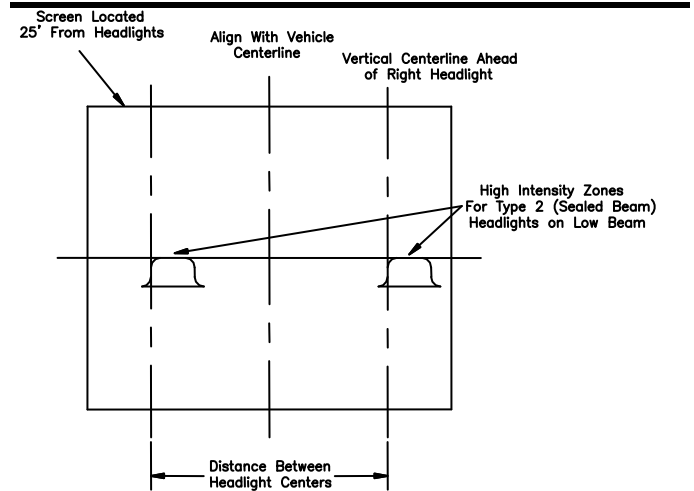

Figure 35. Headlight Aiming Procedure

G10153

6. The correct visual aim for Type 2 headlights is with the top edge of the high intensity zone of the lower beam below the horizontal centerline and the left edge of the high intensity zone on the vertical centerline. See diagram above.

## Hydraulic Valve Assembly Parts List

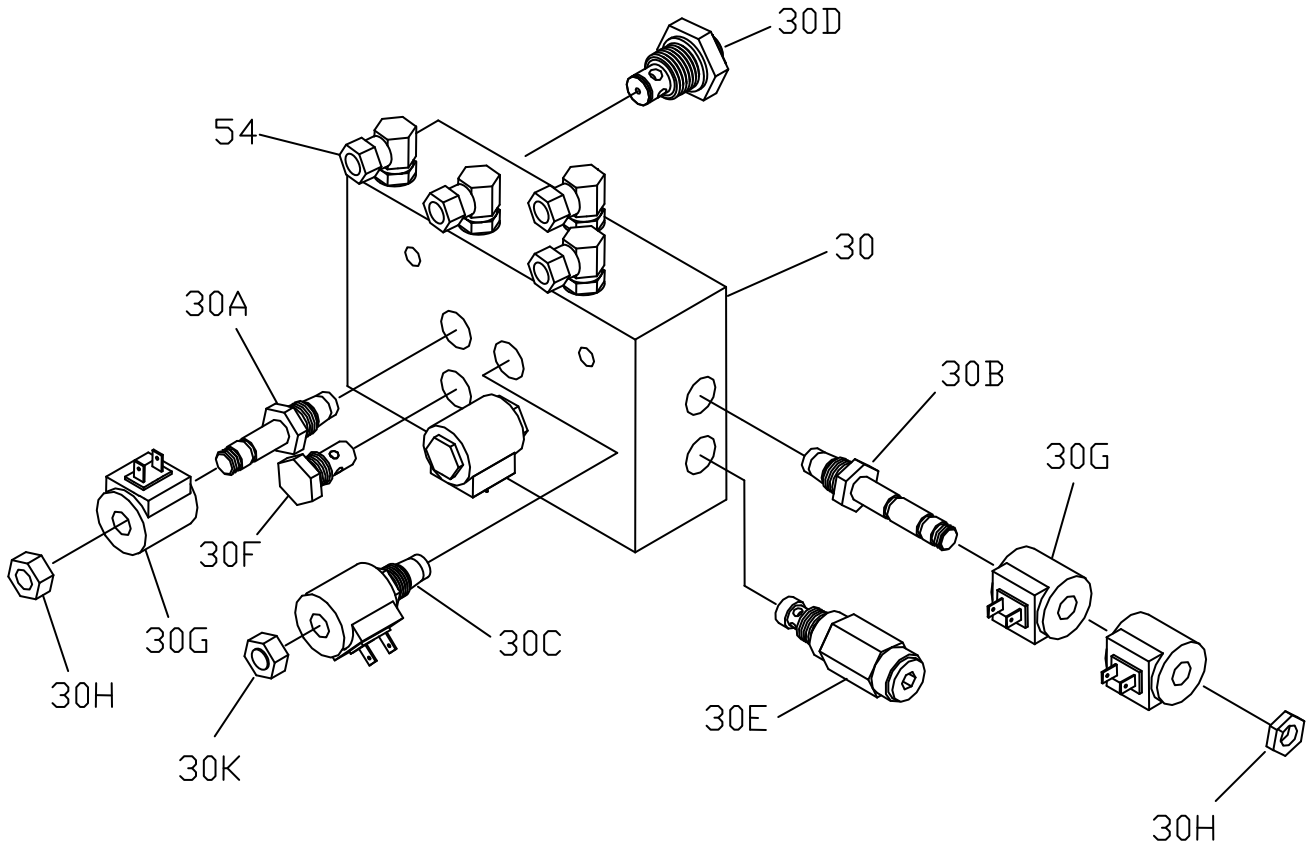
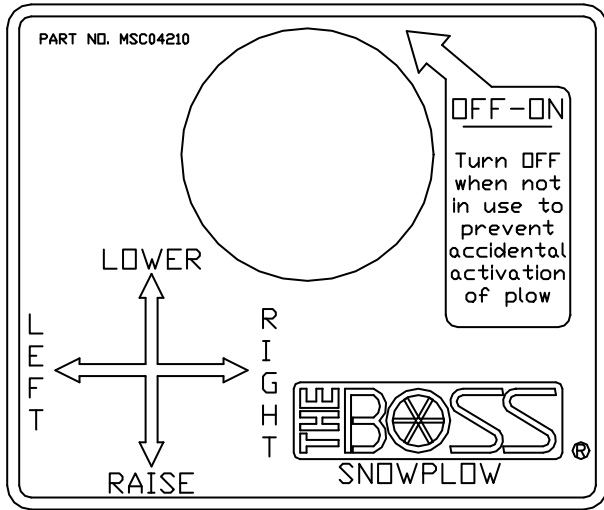

Figure 36. Straight Blade Manifold with SmartHitch2™ Parts Diagram

G10072

Ref.	Description	Part Number	Qty
30	Hydraulic Valve Assembly with SmartHitch2™ (Red)	HYD07091	1
30A	Hydraulic Valve, Lift/Lower Cartridge	HYD01637	2
30B	Hydraulic Valve, Angle Cartridge (3 Position - 4 Way Spool)	HYD07100	1
30C	Hydraulic Valve, SmartHitch2™ Attach	HYD07047	1
30D	Hydraulic Valve, Flow Control Cartridge	HYD07048	1
30E	Relief Valve, Hydraulic Crossover (3,800 PSI)	HYD07027	1
30F	Check Valve	HYD01640	1
30G	Coil, Hydraulic Valve	HYD01638	5
30H	Nut, Coil - used with valve HYD01637 & HYD07100	HYD07059	2
30K	Nut, Coil - used with valve HYD07047	HYD07060	1

## Joystick Control Operating Instructions



**Figure 37.** Straight Blade Control Operation G10154

1. Toggle the ON/OFF switch to the ON position. A red indicator light will illuminate on the switch. The joystick is now active.
2. To RAISE the blade of the plow, pull the control stick towards you.
3. To LOWER the blade of the plow, push the control stick away from you.
4. To FLOAT the blade along the contour of the plowing surface, push the controller away from you until the stick reaches the detent position. (You will feel the stick click into the detent position.) The joystick will stay in the FLOAT position until it is physically re-centered on the control box.

**Note:** The control must be in float to power the SmartHitch.

5. To ANGLE the blade RIGHT, push the controller stick to the right.
6. To ANGLE the blade LEFT, push the controller stick to the left.
7. The control should be turned off when not in use. It can then be unplugged and stored.

## JOYSTICK CONTROL UNIVERSAL MOUNTING KIT MSC04026

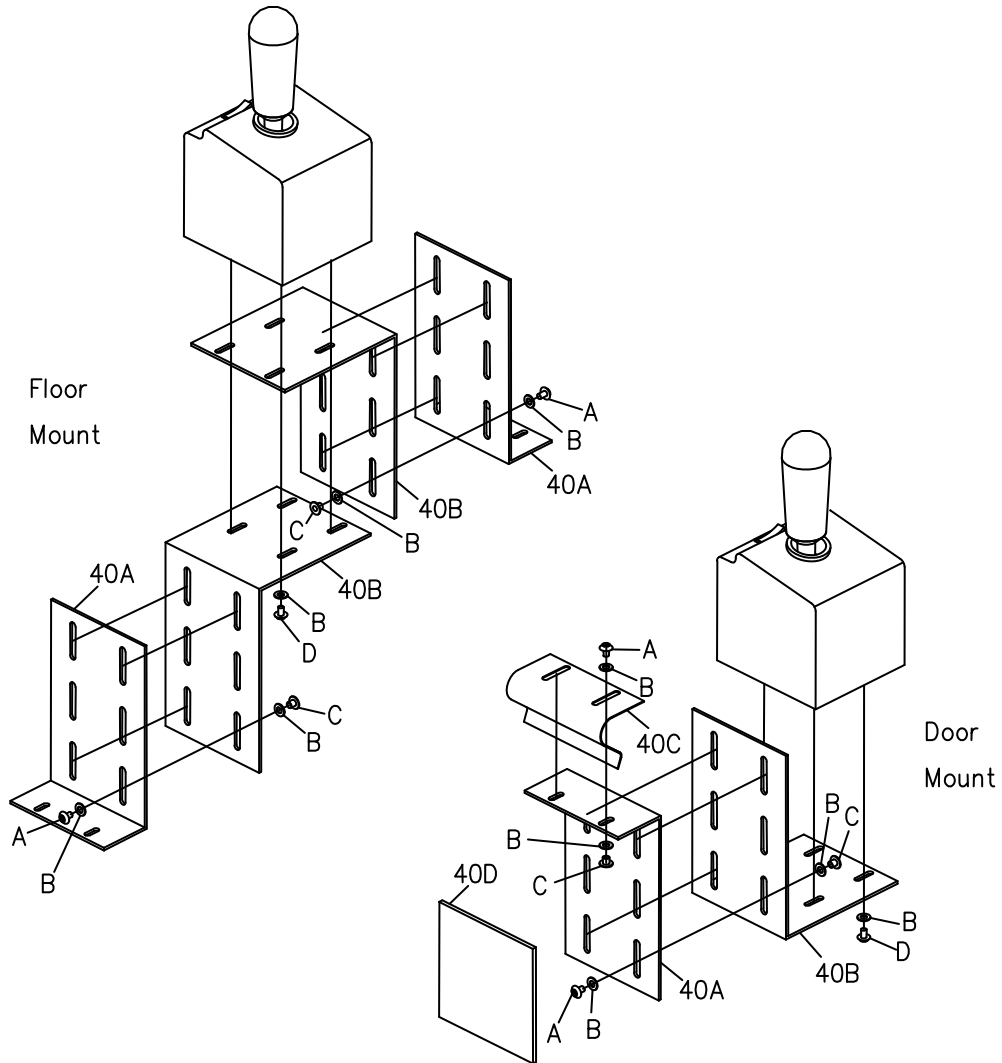

Figure 38. Joystick Control Universal Mounting Kit Component

G10109

Reference Number	Description	Part Number
40A	Joystick, Intermediate Mounting Bracket	MSC04028
40B	Joystick, Mounting Bracket	MSC04029
40C	Joystick, Spring Clip	MSC04027
40D	Pad, Foam	MSC04038
A	Screw, #8-32 X 1/4 Machine Black	HDW05591
B	Washer, #10 Flat Washer Black	HDW05592
C	Nut, #8-32 X 3/16 Alum Binding Post	HDW05593



**SmartTouch** Control  
Operating Instructions

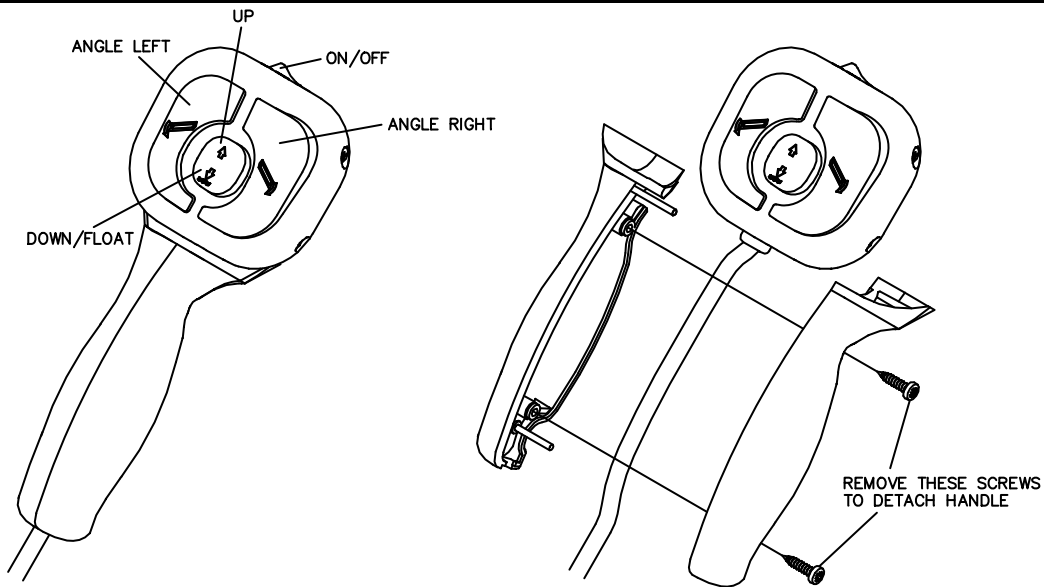

Figure 39. Straight Blade Control Instructions

G10366

**ON/OFF:** Push the ON/OFF switch to the left ON position to turn the control on. Green LED indicators will light up on the control. Push the ON/OFF switch to the right OFF position to turn the control off.

**RAISE:** To raise the blade of the plow, quickly press the center button upward twice. You can also press and hold the center button upward until the blade is fully raised.

**LOWER:** To lower the blade of the plow, quickly push the center button downward twice. You can also press and hold the center button downward until the blade is fully lowered.

**FLOAT:** The plow will automatically activate the FLOAT feature when the center button is quickly pressed downward twice. (The center LED indicator will turn RED). You can also press and hold the center button downward for 2 seconds to activate the FLOAT feature. (The center LED indicator will turn RED).

**“What is FLOAT?”:** The FLOAT feature allows the plow blade to mirror the contour of the ground. Press the raise button to turn the FLOAT function off.

**Note:** The control must be in float to power the SmartHitch.

**ANGLE LEFT:** To angle the blade to the left, press and hold the angle left button until the blade is fully angled.

**ANGLE RIGHT:** To angle the blade to the right, press and hold the angle right button until the blade is fully angled.

**Note:** The control should be turned off when not in use. It can then be unplugged and stored.

**SLEEP mode:** If the controller is ON but not used for 20 minutes, the automatic SLEEP mode will be activated. The controller LED lights will flash green and red when the controller is in SLEEP mode.

**BOSS SmartTouch2 Control Mounting Instructions**

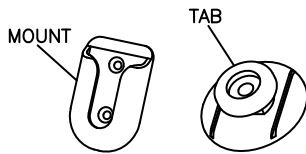

---

**Figure 40.** SmartTouch2™ Mounting Hardware G10311

1. Remove the Swivel Mount and Tab from the Swivel Mount Kit.
2. Use the enclosed alcohol wipe to clean a spot on the vehicle interior where you want to place the SmartTouch2™ Control. Wipe dry immediately with a cloth or paper towel.
3. Do not apply when the surface temperatures are lower than +60 F (Working temperature range of the adhesive is -40 F to +200 F).
4. Peel off the paper backing on one side of the adhesive and apply to Swivel Mount. Apply maximum pressure to all areas.
5. Apply the Swivel Mount onto the spot of the interior that was just cleaned. **MAKE SURE IT IS IN THE CORRECT PLACE.** Once it is placed it cannot be removed without destroying the adhesive.
6. Clean the back of the SmartTouch2™ Control with the alcohol wipe.
7. Peel off adhesive backing of tape, apply to Tab, and press firmly.
8. Remove remaining backing and apply the Tab to the back of the SmartTouch2™ Control. Apply pressure for 30 seconds.
9. Place SmartTouch2™ Control on the Swivel Mount.

**Note:** Other mounting options are available. Contact your BOSS Snowplow dealer for more information.

<p><b>NOTICE</b></p>
----------------------

<p>After attaching the Swivel Mount, let it sit unused for 72 hours before attaching the SmartTouch2™ Control to allow the adhesive to bond to the surface and ensure secure mounting.</p>
--

## Troubleshooting Guide

Glossary of Problems:

1. Pump motor does not run.
2. Pump continues to run with switch in neutral.
3. Plow will not lower.
4. Plow will not raise or raises slowly, motor runs.
5. Blade Angles While Plowing Snow
6. Plow lowers too fast.
7. Blade will not angle, but motor runs.
8. Blade angles too easily while plowing.
9. Oil leaks from cylinders.
10. Battery goes dead with all switches in neutral.
11. Plow lights are dim, will not come on or flicker.
12. Turn signals flash at a rapid rate.
13. High beam indicator light not functioning properly.
14. Plow does not clean-up snow from low areas.
15. Oil runs out of fill cap of hydraulic pump.
16. Pump chatters when raising the plow or angling blade.
17. SmartHitch2™ will not attach plow.
18. Plow lights and truck lights are on at the same time.
19. Plow and truck High and Low beam lights are on at the same time.

PROBLEM	DIAGNOSTIC CHECK	RESULT
1. Pump motor does not run.	Check power/ground cables and control cables are connected properly.	Connect.
	Check for voltage at pump motor while ignition switch is on and LIFT control button is pushed.	If voltage is present, pump motor has failed or pump has seized. Motor brushes may be replaced, otherwise replace pump/motor assembly.
	Check for power to the solenoid by testing for voltage between both large terminals and ground.	If voltage is not present between one large terminal and ground, the cable between the battery and solenoid is disconnected or broken.
	Check for voltage between the other large terminal of the solenoid and ground while jumping power to the small terminals with the white wire.	If NO voltage is present, solenoid has failed and must be replaced. If voltage is present, wire from small terminal of solenoid to ground may be disconnected or broken.

## Troubleshooting Guide

PROBLEM	DIAGNOSTIC CHECK	RESULT
	Test power to the controller by checking voltage between black wire and ground at the white 9-pin connector.	If NO voltage is present, power from fuse box has become disconnected. If voltage is present check wiring and controller switch.
2. Pump continues to run with switch in neutral.	Disconnect controller, ignition ON.	If pump continues to run, solenoid has failed in the closed position. Quickly remove power to the pump by disconnecting the power/ground cables to the plow. Replace solenoid.
		If pump stops running, check wiring of switch box for short between black and white/black wire in controller, or failed switch.
3. Plow will not lower.	Check power/ground cables and control cables are connected properly.	Connect.
	Check flow control valve.	If flow control valve is completely closed, turn controller OFF, then open the flow control valve.
	Check wiring on valve manifold for proper connections.	Refer to the Manifold Wiring Diagram in this manual.
	Check for voltage between solenoid valve terminal and ground with ignition switch on and control switch in FLOAT position.	If voltage is present solenoid valve or valve coil has failed. Replace valve.
	Test power to the controller by checking voltage between black wire and ground at the white 9-pin connector.	If NO voltage is present, power from fuse box has become disconnected. If voltage is present, check wiring and switch of controller.
4. Plow will not raise or raises slowly (pump motor runs).	Check hydraulic fluid level.	Hydraulic fluid level should be within $\frac{3}{4}$ " from top of reservoir when lowered. See Hydraulic Fluid Fill Procedure located in this manual.

## Troubleshooting Guide

PROBLEM	DIAGNOSTIC CHECK	RESULT
	Check that power/ground cables and control cable are connected properly.	Connect.
	Check wiring on valve manifold for proper connections.	Refer to the Manifold Wiring Diagram in this manual.
	Load test battery.	Replace battery if weak or defective.
	Check pressure at pressure port of pump.	If pressure is less than 2500 psi (at end of lift) motor brushes may be defective, pump pressure relief valve may be contaminated, damaged, or set less than 2500 psi, pump may be worn.
	Check LIFT Solenoid Valve	Lift solenoid valve not opening completely. Replace.
	Check Lower Solenoid Valve	Lower solenoid valve not opening completely. Replace.
5. Blade angles while plowing snow.	Check angle solenoid valve on manifold Check pressure	If solenoid valve is contaminated, clean or replace. If pressure relief valve is contaminated, clean or replace.
6. Plow lowers too fast.	Check flow control valve.	Close flow control valve to desired drop speed.
7. Blade will not angle or angles slowly, motor runs.	Check hydraulic fluid level.	Hydraulic fluid level should be within $\frac{3}{4}$ " from top of reservoir when lowered. See Hydraulic Fluid Fill Procedure located in this manual.
	Check power/ground cables and control cable are connected properly.	Connect.
	Check wiring on valve manifold for proper connections.	Refer to the Manifold Wiring Diagram in this manual.
	Load test battery.	Replace battery if weak or defective.
	Check Angle solenoid valve.	Angle solenoid valve not opening completely. Replace.

## Troubleshooting Guide

PROBLEM	DIAGNOSTIC CHECK	RESULT
8. Blade angles too easily while plowing.	Pressure relief valve pressure set too low.	See an Authorized BOSS Dealer for pressure relief valve adjustment.
9. Oil leaks from cylinders.	Inspect fittings and O-rings.	Tighten fittings if loose. See BOSS dealer for seal kit.
	Check rod condition.	If rods are pitted or rough, polish with copus cloth or extra fine steel wool.
10. Battery goes dead with all switches in neutral.	Possible short in switches.	Inspect wiring of controller.
	Possible short in wiring harness.	Repair damaged wire.
	Possible short in valve coils.	Replace coils.
11. Plow lights are dim, will not come on or flicker.	Check electrical connections.	Clean and repair any corroded or damaged terminals.
	Check headlight adapter wires.	Verify proper headlight adapters are being used and are correctly installed.
	Check Relay. Relay should click when activated.	Replace Relay.
12. Turn signals flash at a rapid rate.	Check flasher.	Replace original vehicle flasher with heavy-duty six-amp flasher provided.
13. High beam indicator does not function properly.	Check headlight adapters.	Verify proper headlight adapters are being used and are correctly installed.
	Check electrical connections to plow lights/truck lights toggle switch.	Refer to the Electrical Wiring Diagram in this manual.
14. Plow does not clean-up snow from low areas.	UP/DOWN switch not in FLOAT.	Place switch in FLOAT position.
15. Oil running out of fill cap of hydraulic pump.	Watch customer mount and dismount plow for proper procedure.	Power SmartHitch2™ functions if installed. See Mounting instructions.
	Pump reservoir over filled.	Reservoir should be filled to $\frac{3}{4}$ " from top.
	Hitting snow banks too hard.	Do not plow recklessly.
16. Pump chatters when raising plow or angling blade.	Hydraulic fluid low.	Add hydraulic fluid. Reservoir should be filled to $\frac{3}{4}$ " from top.

## Troubleshooting Guide

---

PROBLEM	DIAGNOSTIC CHECK	RESULT
17. SmartHitch2™ will not attach plow.	Make sure key is on and controller is in FLOAT.	Turn key on and put controller in FLOAT.
	Make sure controller is staying in the FLOAT position.	If controller comes out of FLOAT when using the SmartHitch2™ switch, replace the controller.
	Check valve block and SmartHitch2™ switch for proper connections.	Refer to manifold wiring diagram located within this manual.
18. Plow lights and truck lights are on at the same time.	Check vehicle harness wiring to truck headlights.	Refer to electrical system wiring instructions located within this manual. Ensure OEM is not plugged into truck headlight.
19. Plow and truck High beam and Low beam are on at the same time.	Check headlight adapters for correct connections.	Light adapters for GM trucks can be plugged in two ways. Make sure all four adapters are in the proper orientation for your vehicle.

## Recommended Push Beam Height

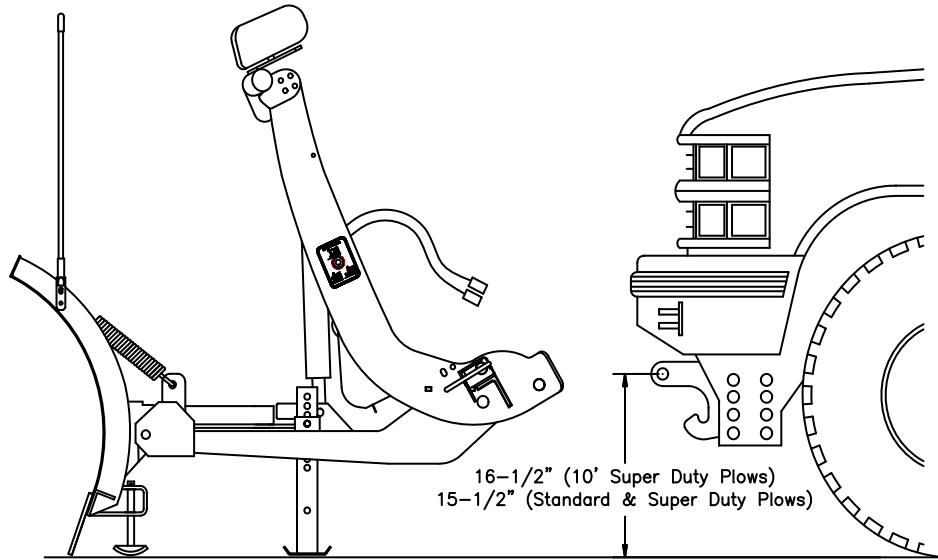

Figure 41. Recommended Push Beam Height

G10155

## Recommended Bolt Torque



DIAMETER / PITCH	GRADE 5	GRADE 8	GRADE 8.8	GRADE 10.9
1/4-20	6	9		
5/16-18	14	19		
3/8-16	23	33		
7/16-14	38	53		
1/2-13	56	80		
9/16-12	82	116		
5/8-11	113	159		
3/4-10	201	283		
M10 X 1.25			36	
M10 X 1.5				49
M12 X 1.75				71
M14 X 2.0				80

ALL TORQUE VALUES ARE IN FOOT-POUNDS (FT.-LB.)

Figure 42. Recommended Bolt Torque

G10410

**NOTE:** The torque values listed above are based on dry, coated bolts, variables such as oil, or other lubrications may appreciably alter these values and must be taken into consideration.

**NOTICE:** IT IS IMPORTANT THAT ALL FASTENERS BE PROPERLY TORQUED TO ASSURE A SAFE OPERATING PLOW. RE-TIGHTEN ALL FASTENERS AFTER 2 HOURS OF PLOWING.