



P.O. Box 787
Iron Mountain, MI 49801
United States

Owner's Manual

Forge Stainless Steel V-Box Spreader

Part No. VBS17100—Serial No. 40000000 and Up

Part No. VBS17110—Serial No. 40000000 and Up

Part No. VBS19600—Serial No. 40000000 and Up

Part No. VBS19610—Serial No. 40000000 and Up

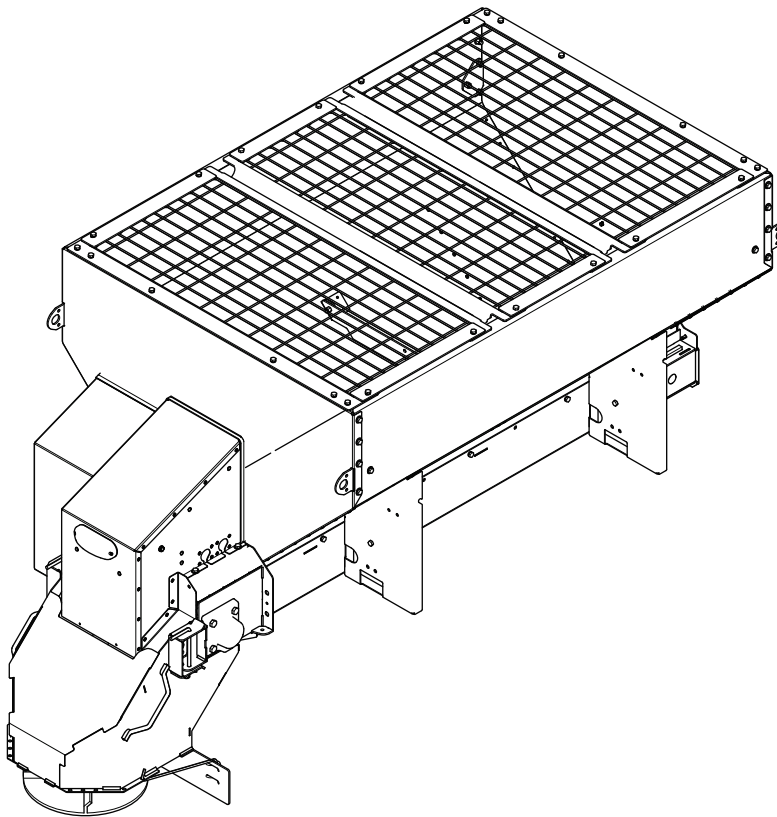

This product complies with all relevant European directives; for details, please see the separate product specific Declaration of Conformity (DOC) sheet.

BOSS Products limited consumer warranty and BOSS Products commercial warranty policies are located at www.bossplow.com.

Patents Pending.

Introduction

Read this information carefully to learn how to operate and maintain your product properly and to avoid injury and product damage. You are responsible for operating the product properly and safely.

You may contact BOSS directly at www.bossplow.com for product and accessory information, help finding a dealer, or to register your product.

Whenever you need service, genuine BOSS parts, or additional information, contact an Authorized BOSS Dealer or BOSS Technical Service (1-800-286-4155) and have the model and serial numbers of your product ready. **Figure 1** identifies the location of the model and serial numbers on the product. Write the numbers in the space provided.

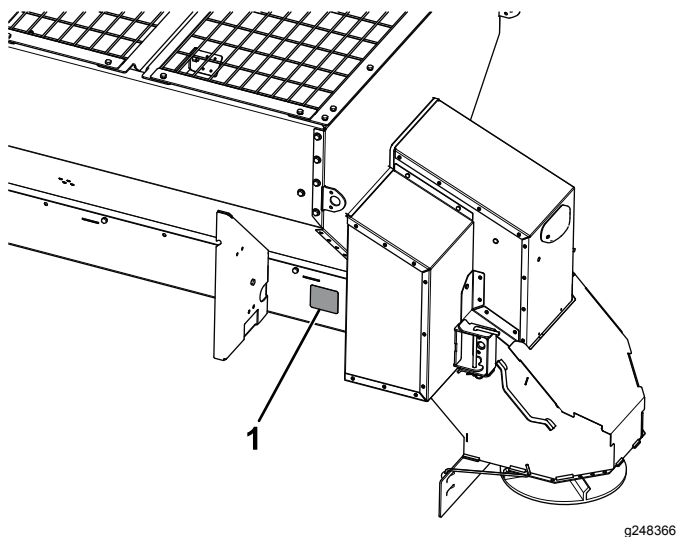

Figure 1

1. Serial number location

Model No. _____
Serial No. _____

This manual identifies potential hazards and has safety messages identified by the safety-alert symbol

(**Figure 2**), which signals a hazard that may cause serious injury or death if you do not follow the recommended precautions.



Figure 2

1. Safety-alert symbol

This manual uses 2 words to highlight information. **Important** calls attention to special mechanical information and **Note** emphasizes general information worthy of special attention.

Contents

Safety	3
Preparation.....	3
Operation.....	3
Safety and Instructional Decals	4
Setup	6
Installing the Wire Harness	6
Mounting the Spreader	8
Adjusting the Slide Stop.....	8
Building and Installing the Spacer	8
Installing the Tie-Down D-Rings.....	9
Securing the Spreader.....	9
Installing the Spinner Assembly	10
Installing the Baffle	10
Installing the Spreader Controller.....	11
Checking the Installation.....	12
Product Overview	13
Controls	13
Specifications	14
Operation	15
Loading the Spreader	15
Operating the Spreader	15
Freeing a Clog	15
Adjusting the Material Deflectors	16
Adjusting the Baffle.....	16
Unloading the Spreader.....	17
Removing the Spinner Assembly	17
Operating Tips	18
Maintenance	19
Recommended Maintenance Schedule(s)	19
Lubrication	19
Greasing the Machine.....	19
.....	19
Adjusting the Pintle-Chain Conveyor Tension	19
Controller Status and Error Indicators	20
Cleaning	21
Cleaning the Machine	21
Storage	22
Troubleshooting	23

Safety

Improper use or maintenance by the operator or owner can result in injury. To reduce the potential for injury, comply with these safety instructions and always pay attention to the safety-alert symbol **A**, which means: **Caution, Warning, or Danger**—personal safety instruction. Failure to comply with the instruction may result in personal injury or death.

Preparation

- Read the *Owner's Manual* before operating or servicing the spreader.
- Ensure that only trained personnel installs and performs maintenance on the equipment.
- Use a 500 kg (1/2 ton) minimum lifting device to move heavy spreader components. Never put any part of your body under a suspended load.
- This spreader has an operating sound level below 70 dBA while inside the vehicle. Wear hearing protection while operating the spreader outside of the vehicle.
- Always wear appropriate personal protective equipment when loading, unloading, and servicing the spreader. Wear substantial, slip-resistant footwear, cold-weather clothing, hard hat, safety glasses, and dust protection.
- Never disable, remove, or relocate any sensors or other components related to the operation of the air bags in your vehicle.

Operation

- Never put any part of your body between the spreader and the vehicle.
- When transporting the spreader, ensure that it is properly secured. Instructions are available at www.bossplo.com.
- Material safety data sheets (MSDS) are available at www.bossplo.com.
- Do not operate the machine while ill, tired, or under the influence of alcohol or drugs.
- For vehicle mounted spreaders, always follow the manufacturer's recommendations for proper parking procedures.
- Always wear your seatbelt while operating a motor vehicle.
- Do not exceed 22 km/h (14 mph) while spreading.
- Do not exceed 72 km/h (45 mph) while transporting the spreader.
- Overloading the spreader could result in an accident or damage. Never exceed the gross-vehicle-weight rating (GVWR) or the front or rear gross-axle-weight ratings (FGAWR or RGAWR) for the vehicle.
- This spreader is restricted to the use of dry, free-flowing salt, sand, and sand/salt mix. Do not run other materials through the spreader.
- Do not attempt to mount or remove the spreader with material in it.
- Turn the vehicle and spreader off before filling, mounting, removing, servicing, or cleaning it.
- Do not operate the spreader within 7.6 m (25 ft) of bystanders.
- Do not climb into or ride on the spreader.
- Keep your hands, feet, and clothing away from moving parts and mounting points.
- Mount the spreader to a vehicle before loading material.
- Install ratchet straps and keep them properly tightened at all times.
- Do not store material in the hopper.

Safety and Instructional Decals



Safety decals and instructions are easily visible to the operator and are located near any area of potential danger. Replace any decal that is damaged or missing.



decalmsc17213

MSC17213

- | | |
|---|---|
| 1. Warning—read the <i>Owner's Manual</i> . | 6. Warning—do not stand or ride on the machine. |
| 2. Loss of control hazard—do not overfill the machine. | 7. Warning—do not open or remove safety shields while the engine is running; keep all shields in place. |
| 3. Warning—turn the machine off before filling. | 8. Warning—the machine must be installed before filling. |
| 4. Warning—empty the hopper and disconnect the power before installing or removing the machine. | 9. Warning—do not store materials in the machine. |
| 5. Thrown object hazard—keep bystanders a safe distance away from the machine. | 10. Warning—turn the machine off and disconnect the power before servicing the machine. |



decalmsc18131b

MSC18131

- Crushing hazard—keep your hands clear.

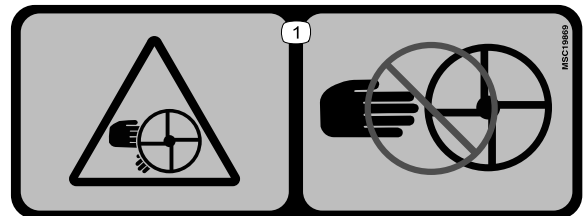

decalmsc19869

MSC19869

- Cutting/dismemberment hazard; spinner—keep your fingers and hands clear of the spinner.

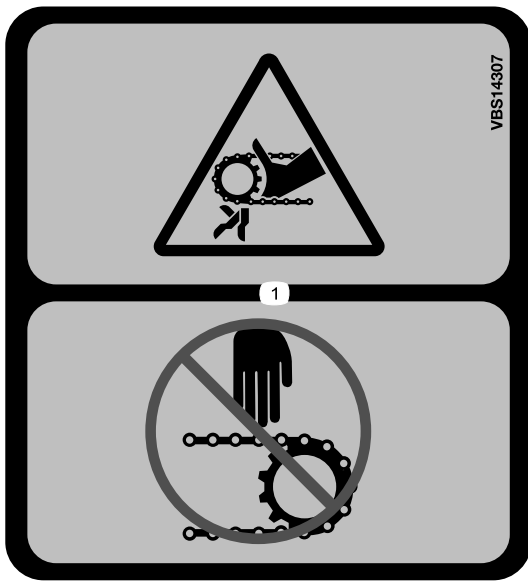

VBS14307

decalvbs14307b

1. Finger/hand entanglement hazard, pintle chain—keep your hands clear.

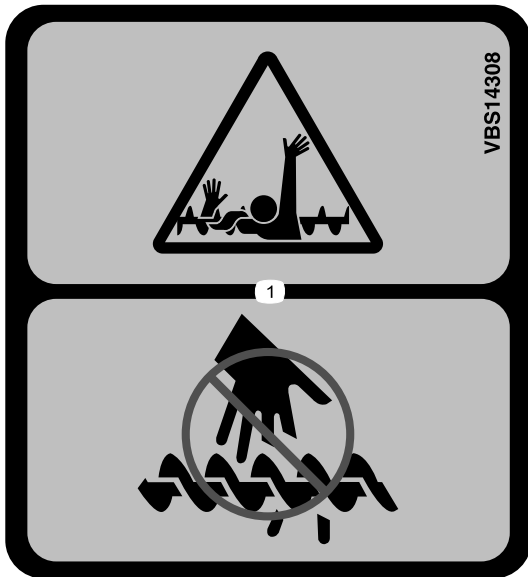

VBS14308

decalvbs14308b

1. Entanglement hazard; auger—keep your hands clear.

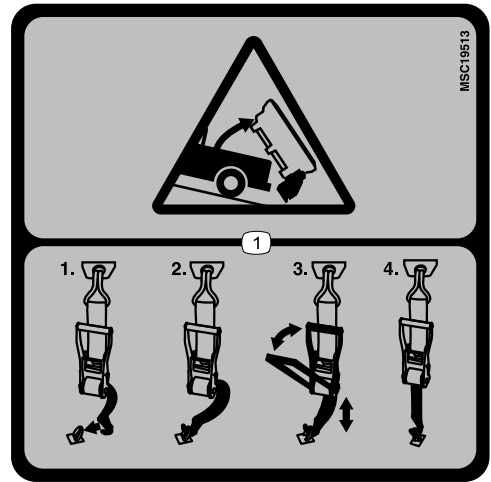

MSC19513

decalmsc19513

1. Loss of machine hazard—the ratchet straps must be secured at all times.

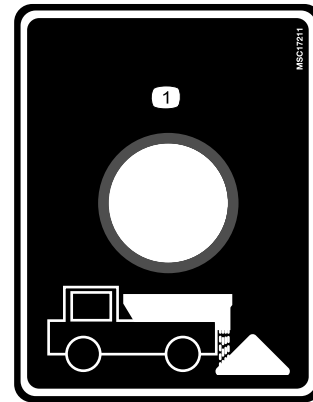

MSC17211

decalmsc17211

1. Dump switch



MSC17843

decalmsc17843

- | | |
|----------------------|---|
| 1. Feeder speed | 4. Vibrator (optional on pintle-chain models) |
| 2. Power | 5. Blast |
| 3. Lights (optional) | 6. Spinner speed |

Setup

Installing the Wire Harness

⚠ DANGER

Vehicle engines contain moving parts and can become extremely hot, capable of causing severe burns and serious bodily harm.

Shut off the engine and allow it sufficient time to cool down before installing this kit.

⚠ DANGER

Vehicle batteries can cause dangerous electrical shocks that could lead to severe burns or death.

Disconnect your battery before installing this kit by removing the negative connector followed by the positive connector.

1. Secure the vehicle-side power/ground and main harness connectors near the center of the rear bumper using cable ties (Figure 3).
2. Route the wire harness along the driver-side frame-rail and into the engine compartment, and secure it with cable ties.

Note: Keep the wire harness away from any hot or moving parts.

3. Insert the controller connector through the firewall and into the vehicle cab, and secure it with cable ties.

Note: Route the connector to the location that you want to install the controller.

4. Install the fuse block within 30 cm (12 inches) of the battery and remove the fuse-block cover.
5. Connect the red power/ground cable to the fuse block (Figure 3).

Note: Ensure that the 150 A fuse is installed.

6. Connect the power cable to the other end of the fuse block (Figure 3).
7. Install the cover onto the fuse block.
8. Connect the power cable to the positive (+) battery post (Figure 3).

Important: Do not connect the ground cable at this time.

9. Connect the red spade connector with the inline fuse to a keyed fuse source on the vehicle (Figure 3).

10. Connect the red spade connector without the inline fuse to the center high-mounted, stoplight fuse if it is available (Figure 3).
11. Connect the white bullet connector to the rear tail-light ground wire using a quick-splice connector (Figure 3).
12. Connect the brown bullet connector to the rear running-lamp wire using a quick-splice connector (Figure 3).
13. Wrap all of the excess wire and secure it in the engine compartment.
14. Connect the black power/ground cable and the controller ground cable to the negative (-) battery post (Figure 3).

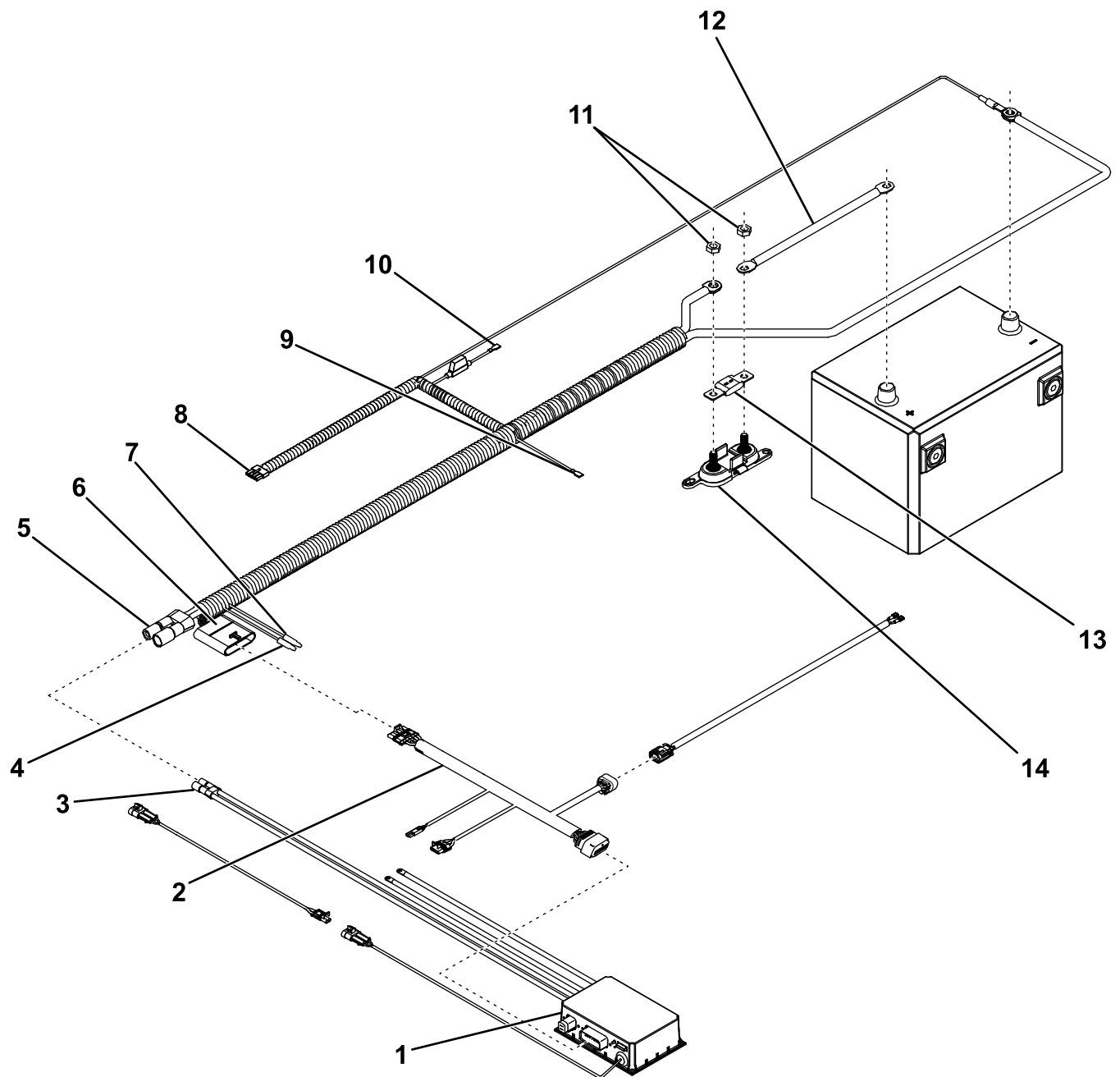

g249328

Figure 3

- | | | | |
|---|--|--|------------------|
| 1. Control module | 5. Vehicle-side power/ground connector | 9. Red spade connector | 13. Fuse (150 A) |
| 2. Spreader-side main harness | 6. Vehicle-side main harness connector | 10. Red spade connector (with inline fuse) | 14. Fuse block |
| 3. Spreader-side power/ground connector | 7. White bullet connector | 11. Nuts (5/16 inch) | |
| 4. Brown bullet connector | 8. Controller connector | 12. Power cable | |

Mounting the Spreader

The minimum truck bed length for the spreader is 2.0 m (78 inches).

1. Remove the tailgate from the vehicle.
2. Using the lift points (Figure 4), lift the spreader onto the truck bed and set it on the centerline.

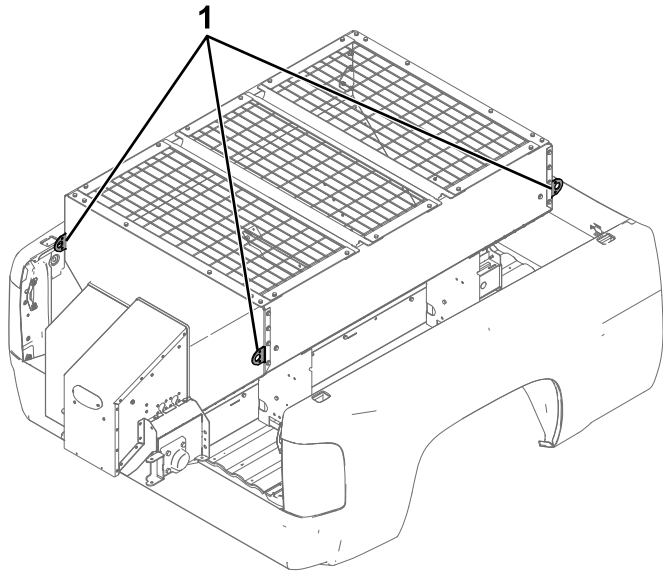

Figure 4

g248367

1. Lift points

3. Slide the spreader toward the vehicle cab until the slide stop hits the truck bed (Figure 5).

Note: The truck bed must be at least 2.0 m (78 inches) long.

Note: If the spreader is flush with the truck box but the slide stop is not touching the rear bumper, refer to [Adjusting the Slide Stop](#) (page 8).

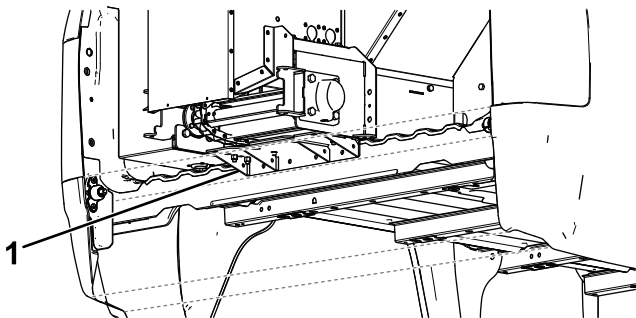

Figure 5

g248333

1. Slide stop

4. Drill 4 holes (7/16 inch) into the truck bed aligned with the slide stop holes.
5. Secure the slide stop to the vehicle using 4 bolts, 4 locknuts, and 16 flat washers.

Note: Slide stop fasteners are not included.

6. Torque the bolts to the appropriate specification.

Adjusting the Slide Stop

Optional

You can adjust the slide stop of the spreader 2.5 cm (1 inch) or 5 cm (2 inches) so that the spreader does not extend past the truck box.

1. Remove and retain the carriage bolts securing the slide stop.
2. Slide the spreader so that it does not extend past the truck box and contact the vehicle cab.
3. Move the slide stop to the desired position and secure it with the previously removed carriage bolts (Figure 6).

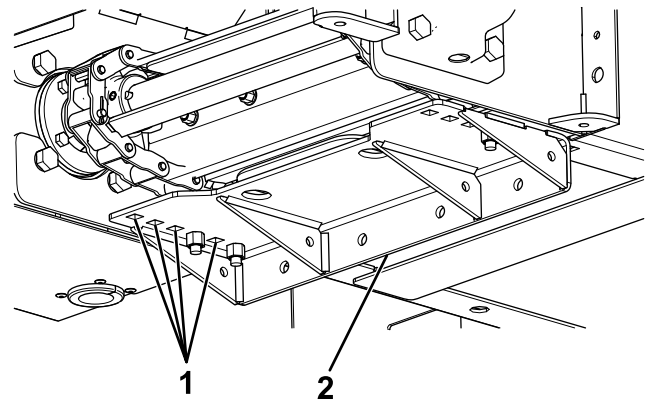

Figure 6

g214851

1. Slide-stop adjustment
2. Slide stop holes

4. Torque the bolts to 28 N·m (19.7 ft-lb).

Building and Installing the Spacer

1. Measure the distance from the front of the truck box to the spreader.
2. Using 3.8 x 18.4 cm (1-1/2 x 7-1/4 inch) lumber, build the spacer as shown in Figure 7.

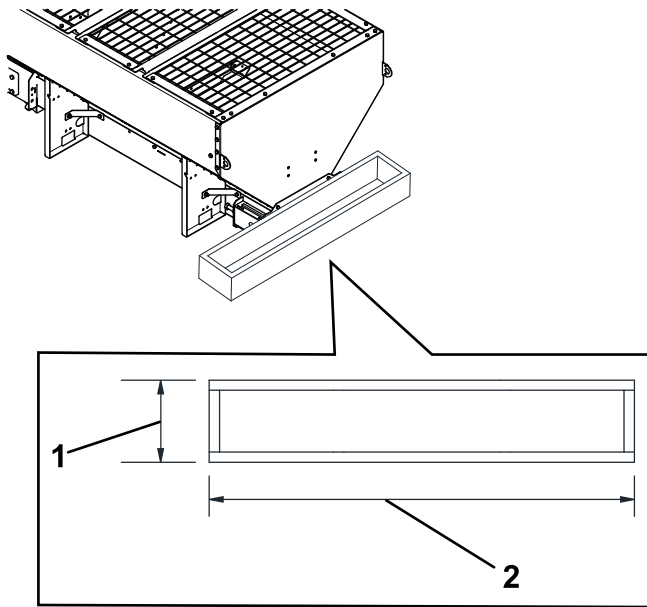

Figure 7

g248336

1. Distance between the spreader and the truck box
2. Width of the truck box spreader

3. Insert the spacer between the spreader and the front of the truck box.

Installing the Tie-Down D-Rings

1. Mark and drill the holes (7/16 inch) for the D-rings starting with the D-rings closest to the cab, as shown in Figure 8. The cab side D-rings will be positioned inside the spacer.

Note: Drill the holes through or near the frame cross-members of the vehicle.

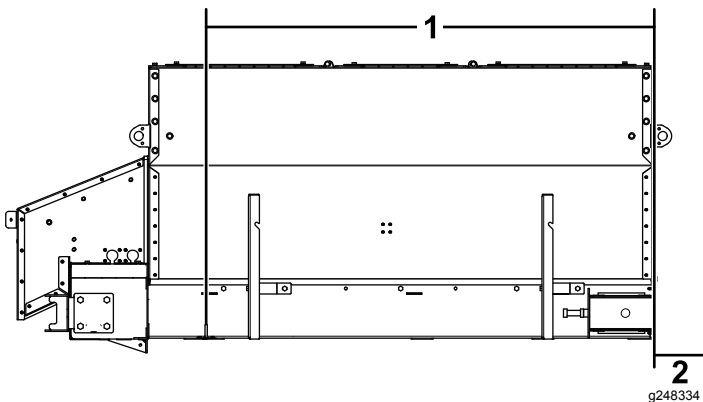

Figure 8

g248334

1. D-ring center to the D-ring center—163.8 cm (64.5 inches)
2. Back of the spreader to the D-ring center—25.4 cm (10 inches)

2. Install the D-rings as shown in Figure 9 and torque the bolts to 28 N·m (19.7 ft-lb).

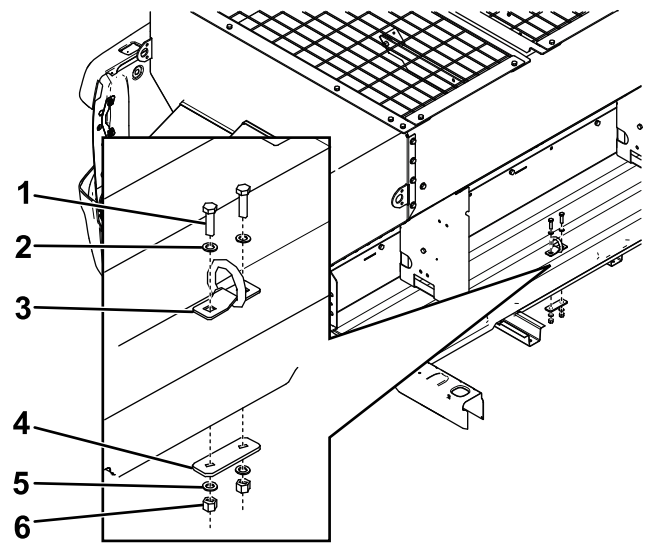

Figure 9

g248335

1. Bolt (3/8 x 1-1/2 inches)
2. Flat washer (3/8 inch)
3. D-ring
4. Bedmount plate
5. Flat washer (3/8 inch)
6. Locknut

Securing the Spreader

⚠ DANGER

The spreader is heavy and could cause serious injury or property damage if it falls off the vehicle.

Ensure that the ratchet straps are securely attached to the spreader at all times.

1. Connect the ratchet straps to the D-rings around the upper edge of the spreader (Figure 10).

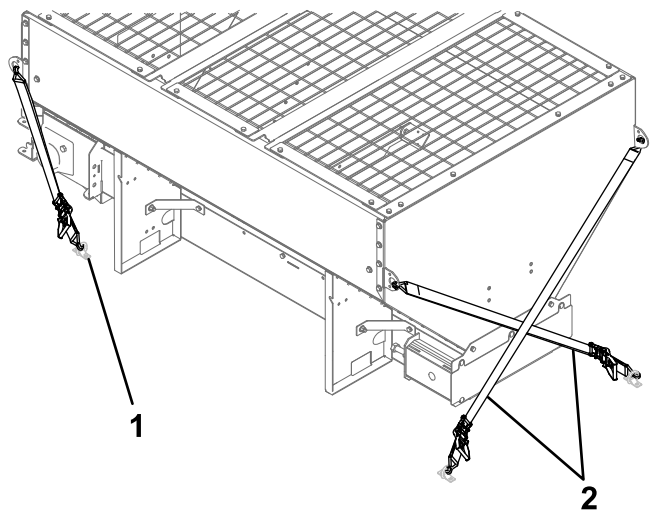

Figure 10

g248337

1. D-ring
2. Ratchet straps

2. Cross the straps near the vehicle cab and attach them to the D-rings opposite to them on the truck bed (Figure 10).
3. Attach the straps near the rear of the vehicle to the D-rings nearest them on the truck bed (Figure 10).
4. Tighten the straps evenly to secure the spreader.

Installing the Spinner Assembly

1. Remove and retain the latch and cotter pins from the spinner assembly (Figure 11).

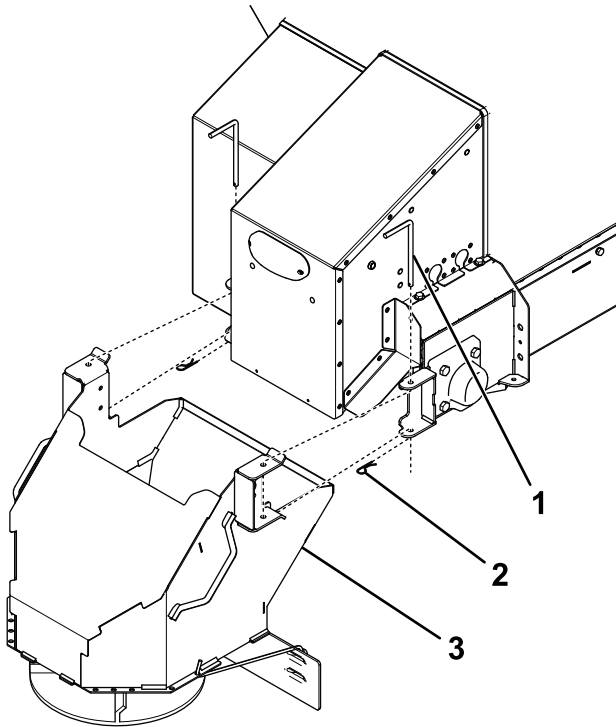

Figure 11

g248339

1. Latch pin
2. Cotter pin
3. Spinner assembly

2. Attach the spinner assembly to the spreader and secure it with the previously removed latch and cotter pins (Figure 11).

Important: The spinner assembly is heavy and requires 2 people to lift.

3. Connect the wire harness.

Installing the Baffle

Optional

If your machine does not come standard with a baffle and you have ordered 1, install it as follows:

1. Remove the top screen from the spreader.
2. Remove the rear cover from the hopper.

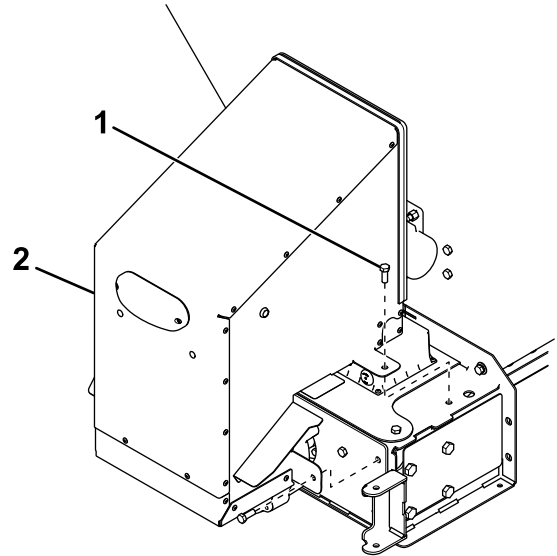

Figure 12

g223387

1. Bolt
2. Rear cover

3. Remove and discard the 4 outer plugs from the rear of the spreader (Figure 13).

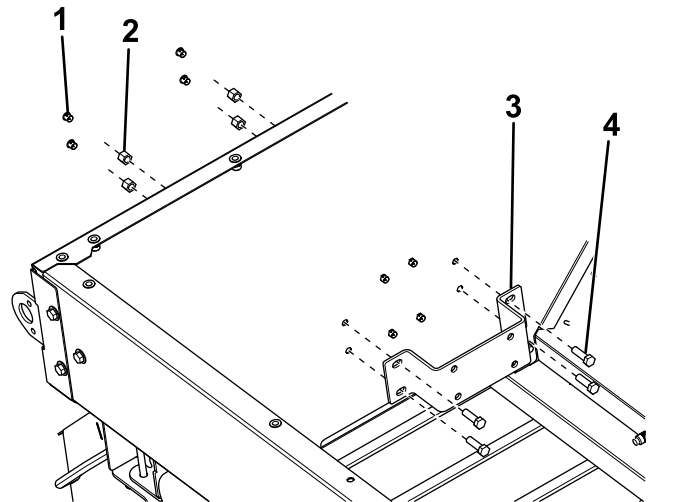

Figure 13

g248379

1. Plug (discard)
2. Nut (3/8 inch)
3. Mounting bracket
4. Bolt (3/8 x 1-1/4 inches)

4. Secure a baffle mounting bracket to the inside rear of the spreader using 4 bolts (3/8 x 1-1/4 inches) and nuts (Figure 13).

- Remove and discard the 4 plugs from the front of the spreader (Figure 14).

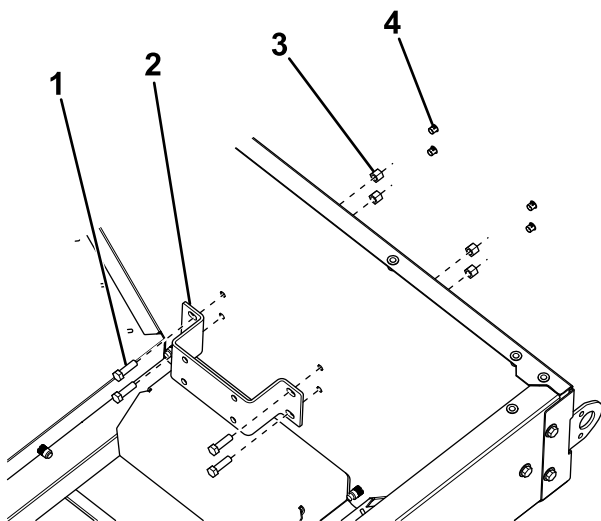

Figure 14

g248380

- | | |
|------------------------------|-------------------|
| 1. Bolt (3/8 x 1-1/4 inches) | 3. Nut (3/8 inch) |
| 2. Mounting bracket | 4. Plug (discard) |

- Secure a baffle mounting bracket to the inside front of the spreader using 4 bolts (3/8 x 1-1/4 inches) and nuts (Figure 14).
- Secure 1 end of the baffle to the front mounting bracket using 4 bolts (3/8 x 1-1/4 inches) and nuts (Figure 15). Repeat on the rear mounting bracket.

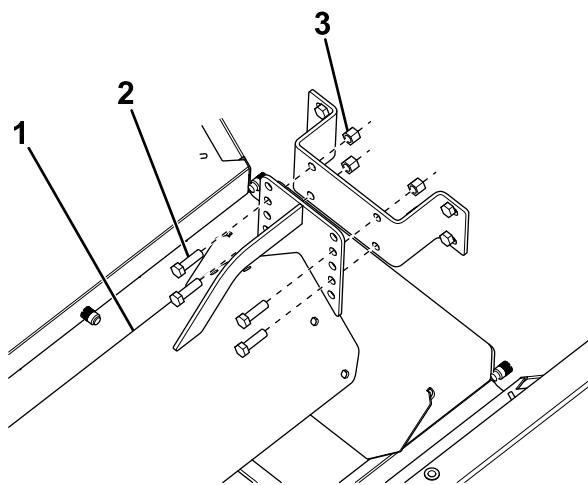

Figure 15

g248381

- | | |
|------------------------------|-------------------|
| 1. Baffle | 3. Nut (3/8 inch) |
| 2. Bolt (3/8 x 1-1/4 inches) | |

- Align the free ends of the baffles and secure them to each other and the spreader cross-bracket using 4 bolts (3/8 x 1-1/4 inches) and nuts (Figure 16).

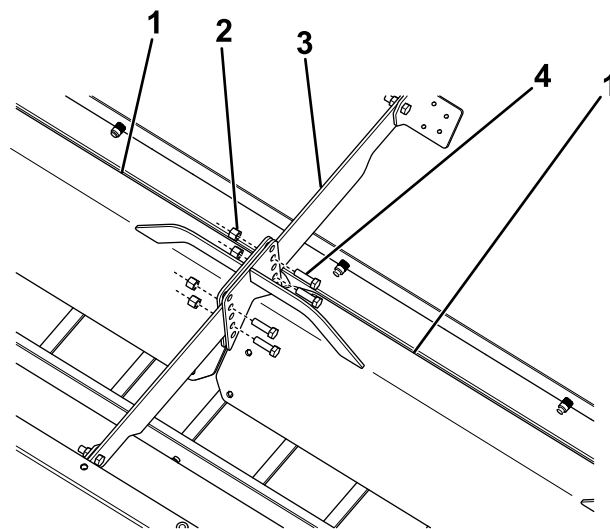

Figure 16

g248382

- | | |
|-------------------|------------------------------|
| 1. Baffle | 3. Cross-bracket |
| 2. Nut (3/8 inch) | 4. Bolt (3/8 x 1-1/4 inches) |

- Install the previously removed rear cover and top screen.

Installing the Spreader Controller

Mount the controller in the cab where it does not interfere with vehicle operation or visibility.

Important: Do not mount the controller in a location that vehicle occupants could contact it during a crash.

- Attach the mounting bracket to the vehicle using either 2 hook and loop fasteners or 2 sheet-metal screws (Figure 17).

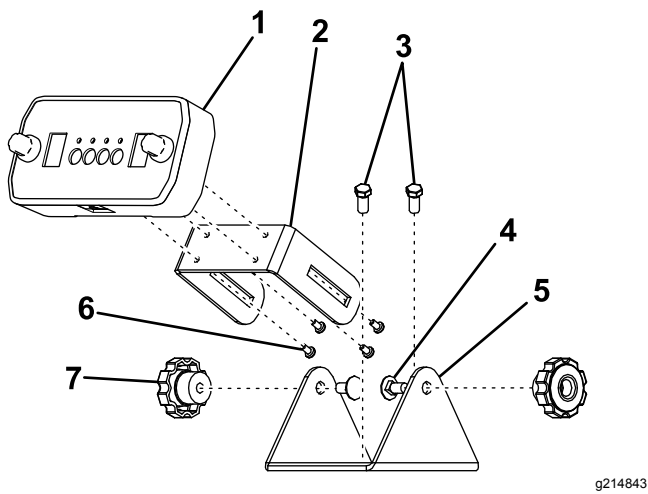

Figure 17

- | | |
|-----------------------|---------------------|
| 1. Controller display | 5. Mounting bracket |
| 2. Sliding bracket | 6. Pan-head screws |
| 3. Sheet-metal screws | 7. Thumb nut |
| 4. Carriage bolt | |

2. Connect the controller display to the sliding bracket using 4 pan-head screws (Figure 17).
3. Attach the sliding bracket to the mounting bracket using 2 carriage bolts and thumb nuts (Figure 17).

Note: Position the controller screen so that it is clearly visible to the driver.

4. Connect the wire harness controller connector to the controller display.

Checking the Installation

1. For pintle-chain models, check the pintle-chain conveyor tension; refer to [Adjusting the Pintle-Chain Conveyor Tension \(page 19\)](#).
2. Check that the unit type listed on the controller display matches your machine type.
 - A. Hold the Power button until the display turns off.
 - B. Hold the Blast button and press the Power button.
 - C. After the software revision numbers are displayed, either an “A” or “P” will appear. “A” designates an auger unit. “P” designates a pintle chain unit.

Note: If the unit type does not match your machine, contact your Authorized BOSS Dealer about adjusting the control module.

Product Overview

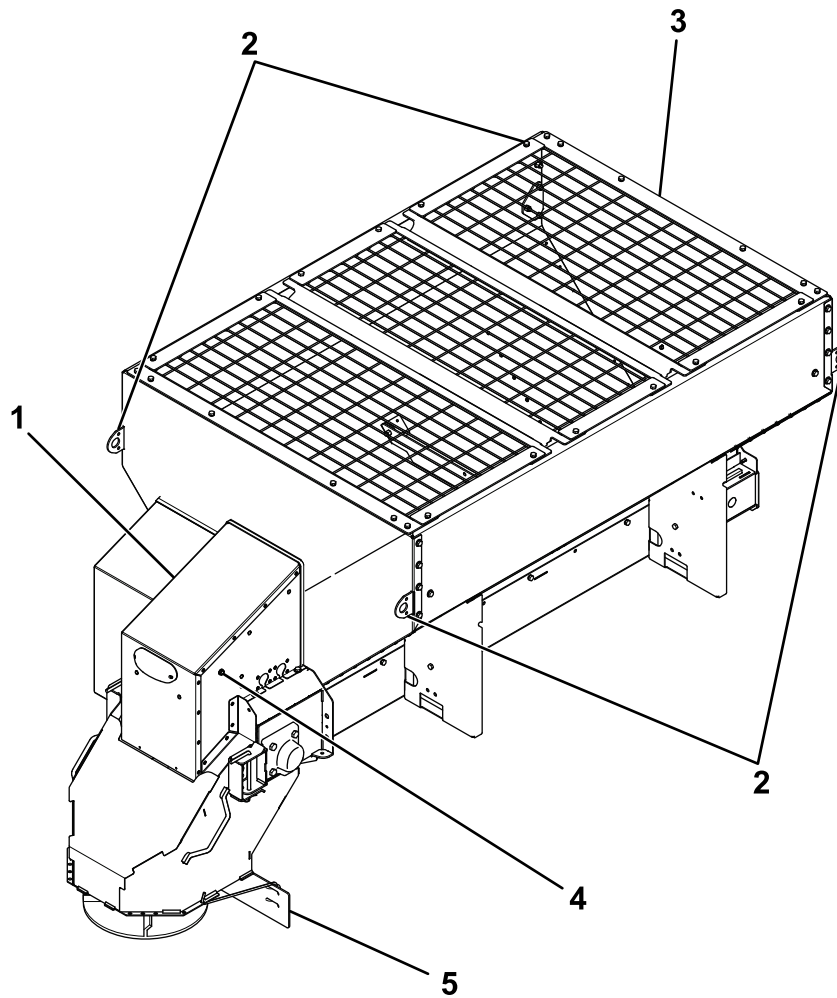

Figure 18

g248361

- 1. Rear cover
- 2. Lift points
- 3. Top screen

- 4. Dump switch
- 5. Material deflector

Controls

Become familiar with all the controls before you operate the spreader.

Material Deflector

The material deflector controls the spread of materials; you can adjust the controls to provide different spread patterns; refer to [Adjusting the Material Deflectors](#) (page 16).

Dump Switch

The dump switch activates the spreader and empties out the contents. Press and hold the switch to empty the spreader.

⚠ CAUTION

When outside of the vehicle cab, this machine produces sound levels that can cause hearing loss through extended periods of exposure.

Wear hearing protection while operating the dump switch.

Spreader Controller

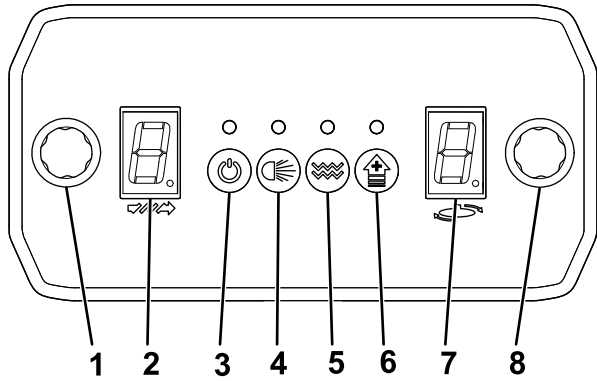

Figure 19

g214836

- | | |
|-------------------------|----------------------------|
| 1. Feed speed dial | 5. Vibrate button |
| 2. Feed speed indicator | 6. Blast button |
| 3. Power button | 7. Spinner speed indicator |
| 4. Light button | 8. Spinner speed dial |

- Feed speed dial—increases the feed motor speed when turned clockwise, and decreases the feed motor speed when turned counterclockwise. The feed speed determines how quickly material is pulled from the hopper.
- Feed speed indicator—indicates the feed motor speed
- Power button—turns the feeder, spinner, and vibrator (if active) motors on or off
- Light button—turns the optional rear lights on or off
- Vibrate button—switches the vibrator on or off

Note: The vibrator only runs when the feeder motor is on.

Note: The vibrator is optional on pintle-chain spreaders.

- Blast button—momentarily sends full power to the feed and spinner motors in 2 second bursts. Holding the button increases the motors to full speed for 2 seconds and then pauses for 2 seconds then repeats until you release the button. The Blast button works only if the feed and spinner motors are set at less than maximum speed.
- Spinner speed display—indicates the spinner motor speed
- Spinner speed dial—increases the spinner motor speed when turned clockwise, and decreases the spinner motor speed when turned counterclockwise. The spinner speed determines how far the material is thrown.

Specifications

Note: Specifications and design are subject to change without notice.

	Forge 1.5	Forge 2.0
Length	2.48 m (98 inches)	2.48 m (98 inches)
Hopper height	85.1 cm (33.5 inches)	97.7 cm (38.5 inches)
Hopper width	124.5 cm (49 inches)	124.5 cm (49 inches)
Weight (empty)	317 kg (700 lb) with auger; 340 kg (750 lb) with pintle chain	329 kg (725 lb) with auger; 352 kg (775 lb) with pintle chain
Capacity	1.15 m ³ (1.5 yd ³)	1.5 m ³ (2 yd ³)

Operation

Note: Determine the left and right sides of the machine from the normal operating position.

Loading the Spreader

Important: Only use dry salt, sand, sand/salt, or cinder/salt mixes in the spreader. Other materials could cause damage to the machine.

The density of materials that can be loaded into the spreader varies and therefore so will the amount of a given material that can be carried by the spreader before the maximum load rating is reached.

Important: When filling the spreader, do not exceed the gross-vehicle-weight rating (GVWR) or gross-axle-weight rating (GAWR).

1. Ensure that the spreader is securely mounted to the vehicle and that the top screen is installed and closed.
2. Determine the amount of material that you can safely transport using the GVWR/GAWR of the vehicle and the following table.

Material Type	Weight Range
Fine salt	1,121 to 1,281 kg/m ³ (1,890 to 2,160 lb/yd ³)
Coarse salt	721 to 961 kg/m ³ (1,215 to 1,620 lb/yd ³)
Coarse sand (dry)	1,442 to 1,762 kg/m ³ (2,430 to 2,970 lb/yd ³)
Coarse sand (wet)	1,762 to 2,082 kg/m ³ (2,970 to 3,510 lb/yd ³)
Cinders	641 kg/m ³ (1,080 lb/yd ³)

3. Fill the spreader evenly with the material, making sure not to fill past the top of the hopper.

Important: Overfilling the hopper could damage the spreader and the vehicle.

Operating the Spreader

⚠ DANGER

Hands, feet, and clothing can get caught in the moving parts of the spreader and cause serious bodily injury and loss of limbs.

Keep your hands, feet, and clothing away from the moving spinner, auger, chain, and attachment points.

⚠ CAUTION

The spreader throws material at a high speed that could cause minor injuries to bystanders.

Bystanders should stay a minimum of 7.6 m (25 ft) away from operating spreaders.

1. Start the vehicle.

Note: The controller display should light up when you start the vehicle.

2. Use the controller to set the desired feed speed and spinner speed.

Note: You can adjust the feed and spinner speeds while the spreader is operating.

3. If you plan to use the vibrator during spreading, turn it on now.

Note: The vibrator does not start until you start the feed motor.

4. Press the Power button to activate the spreader.

Note: Always check for bystanders before starting the spreader.

5. While spreading, you can press the Blast button to momentarily increase the speed of the feed and spinner motors.

6. Press the Power button when you are finished spreading to stop the spreader.

7. Empty the leftover materials from the spreader; refer to [Unloading the Spreader \(page 17\)](#).

Freeing a Clog

The LED above the Power button turns orange and the feeder/spinner speed indicators flash when debris gets wedged in the auger or pintle chain, or under the spinner disk.

1. Do not turn off the machine when a jam first occurs.

Note: The spreader is designed to automatically free clogs.

2. If the LED above the Power button is flashing red or the feeder/spinner speed indicators are flashing, push the Power button.

Note: If the machine does not clear the clog after several attempts, the motor goes into a cooldown mode for 3 minutes.

- If the clog is not cleared automatically, disconnect the spreader wire harness and manually free the clog.

⚠ WARNING

Moving parts on the spreader can entangle hands and cut or dismember fingers.

- Disconnect the spreader wire harness before attempting to manually free a clog.
- If the top screen is opened, ensure that all bolts are secured after freeing the clog.

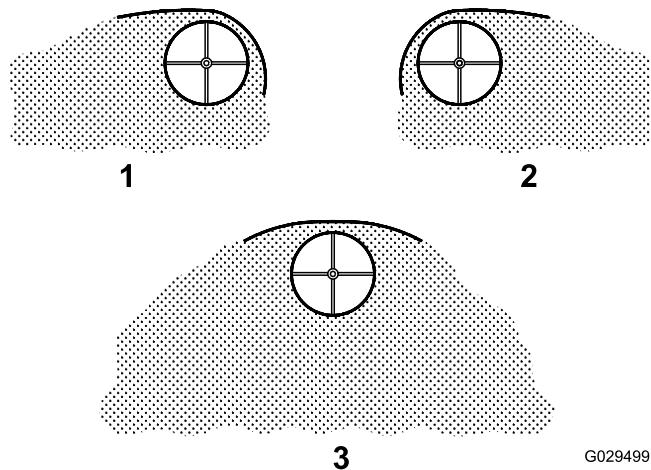

Figure 21
Deflection Settings

1. Driver side open
2. Passenger side open
3. Both sides open

G029499
g029499

Adjusting the Material Deflectors

You can adjust the material deflectors by inserting the deflector pins into the staggered holes around the spinner (Figure 20).

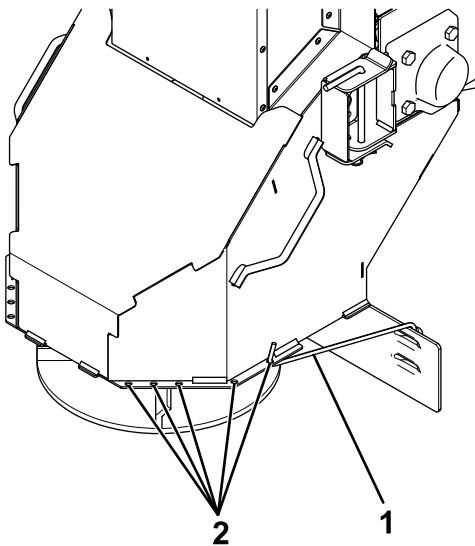

Figure 20

1. Material deflector
2. Adjustment holes

g214842

You can adjust the spread pattern by positioning the deflectors as shown in Figure 21.

Adjusting the Baffle

1. Empty the spreader hopper; refer to [Unloading the Spreader \(page 17\)](#).
2. Unplug the spinner harness from the main wire harness.
3. Remove the top screen from the spreader.
4. Remove the hardware securing the baffle to the inside of the spreader (Figure 22).

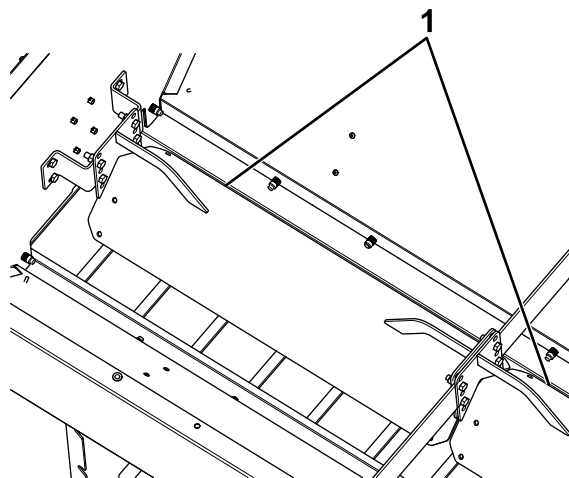

Figure 22

1. Baffle

g248383

5. Raise or lower the baffle to the desired height and secure it with the previously removed hardware (Figure 22).

Note: Raising the baffle increases the flowrate and load on the feeder. Lowering the baffle decreases the flowrate and load on the feeder.

- Secure the previously removed top screen, and connect the spinner harness to the main wire harness.

- Connect the spinner harness to the main wire harness.

Unloading the Spreader

Important: Do not leave material in the hopper as it could damage the machine.

- Position the spreader in the area where you want to deposit the material.
- Unplug the spinner harness from the main wire harness.
- Remove the left latch and cotter pin from the spinner assembly (Figure 23).

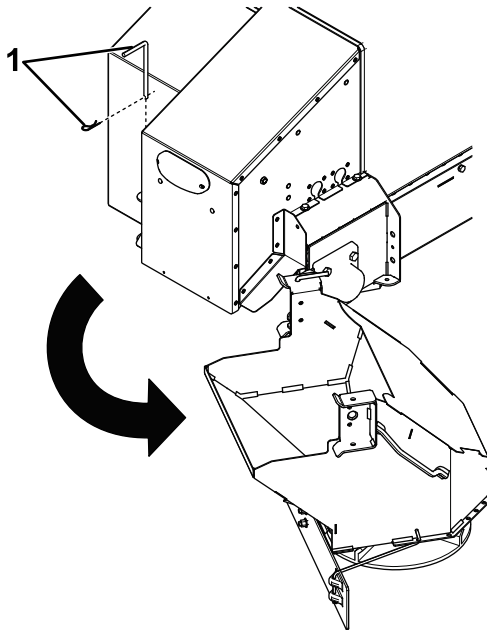

Figure 23

g248362

- Latch and cotter pin

- Swing the spinner assembly free from the hopper opening (Figure 23).

Note: Do not move the vehicle when the spinner assembly is swung out.

- Push and hold the dump switch to unload the hopper material.

⚠ CAUTION

The spreader throws material at a high speed that could cause minor injuries.

Stand to the side of the spreader when activating the dump switch.

- Swing the spinner assembly back into place and secure it with the previously removed attachment pin and cotter pin.

Removing the Spinner Assembly

- Position the spreader over a flat, dry surface.
- Unplug the spinner harness from the main wire harness.
- Remove the 2 latch and cotter pins securing the spinner assembly to the hopper (Figure 24).

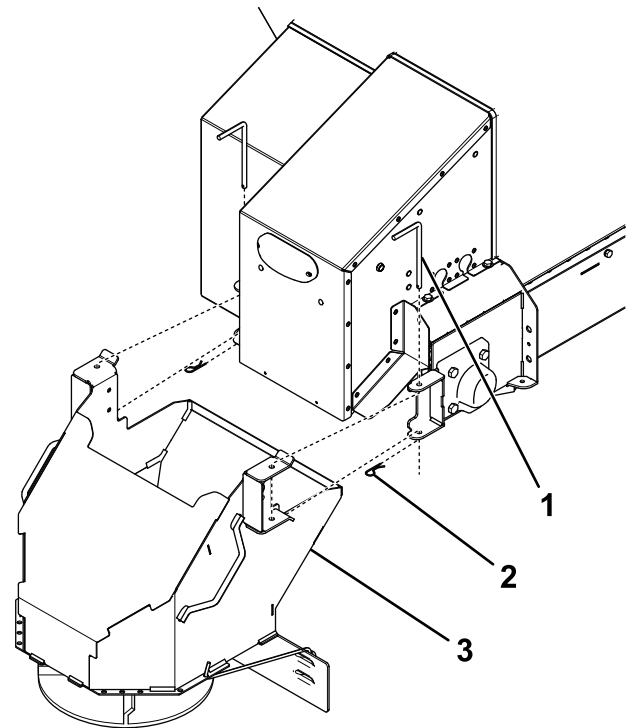

Figure 24

g248363

- Latch pin
- Cotter pin
- Spinner assembly

- Remove the spinner assembly.

⚠ DANGER

The spinner assembly is heavy and could cause serious injury if dropped.

Ensure that your footing is stable, and avoid removing the spinner assembly near slippery or uneven surfaces.

- Insert the attachment pins and cotter pins into the spinner assembly for storage.

Operating Tips

- Know the area in which you are working; hidden obstructions such as curbs, sidewalks, and pipes can damage the spreader or vehicle.
- Do not let the ice build up; always start as soon as possible.
- Always wear your seatbelt when spreading.
- Always remember to spread at a safe speed.
- Never ride on or put body parts into the spreader while servicing or operating it.

Maintenance

⚠ WARNING

Failure to properly maintain the machine could result in premature failure of machine systems causing possible harm to you or bystanders.

Keep the machine well maintained and in good working order as indicated in these instructions.

⚠ CAUTION

If you leave the key in the switch, someone could accidentally start the engine and seriously injure you or other bystanders.

Remove the key from the switch before you perform any maintenance.

Note: Determine the left and right sides of the machine from the normal operating position.

Recommended Maintenance Schedule(s)

Maintenance Service Interval	Maintenance Procedure
Before each use or daily	<ul style="list-style-type: none">• Check the ratchet straps and tighten as necessary.• Check the pintle-chain conveyor tension.• Empty the cleanout tray.
Every 20 hours	<ul style="list-style-type: none">• Grease the bearings.• Grease the pintle chain (pintle-chain models only).• Tighten the hardware.
Before storage	<ul style="list-style-type: none">• Unload the spreader.• Clean and grease all of the bearings.• Clean and grease the pintle chain (pintle-chain models only).

Lubrication

Greasing the Machine

Every 20 hours—Grease the bearings.

Every 20 hours—Grease the pintle chain (pintle-chain models only).

Grease all of the bearings, and pintle chain (for models with a pintle chain), with a No. 2 lithium grease.

Adjusting the Pintle-Chain Conveyor Tension

Pintle-Chain Models Only

Service Interval: Before each use or daily—Check the pintle-chain conveyor tension.

1. Disconnect the power/ground cable and main harness from the wire harness.
2. Remove the back cover shown in [Figure 25](#).

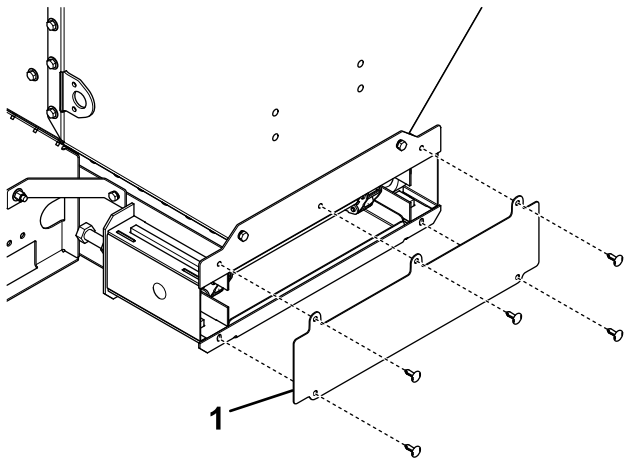

Figure 25

g215002

1. Back cover

3. Check the gap between the pintle chain and the cleanout tray ([Figure 26](#)).

Note: The chain should hang 2.5 to 5 cm (1 to 2 inches) above the cleanout tray.

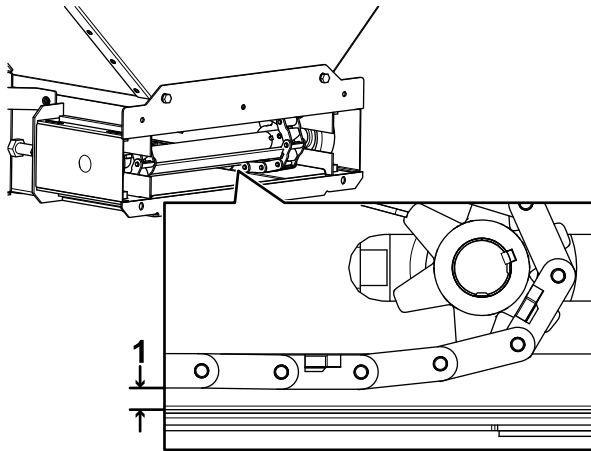

Figure 26

g215001

1. Gap between the pintle chain and the cleanout tray

4. To adjust the tension, loosen the jam nuts on the sides of the spreader ([Figure 27](#)).

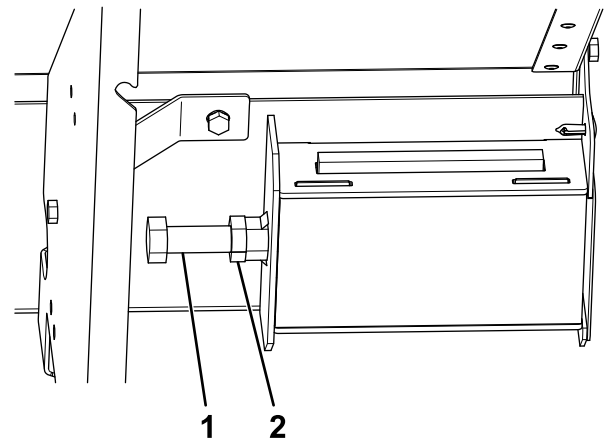

Figure 27

g214847

1. Take-up bolt
2. Jam nut

5. Turn the left take-up bolt clockwise 1 to 3 revolutions.
6. Turn the right take-up bolt clockwise 1 to 3 revolutions.
7. Check the chain tension, and repeat steps 5 and 6 until the desired tension is reached.

Note: Do not overtighten the pintle chain as it could lead to premature wear and spreader failure.

8. Tighten the jam nuts.
9. Connect the power/ground cable and main harness to the wire harness.

Controller Status and Error Indicators

The following icons and messages indicate that an error has occurred with your machine. Refer to [Troubleshooting \(page 23\)](#) for possible solutions.

Feeder and spinner errors only appear in 1 location or the other, not both.

- All LEDs flash red and the controller beeps once—indicates that the controller has no communication with the control module
- At key start, the LED of a button flashes red—indicates that a button is pressed or stuck down when the controller is powered up
- The vibrator LED flashes red—indicates that the vibrator is disconnected or not running properly
- The Power LED is red and the feeder or spinner speed indicator is flashing—indicates that the feeder or spinner motor is disconnected or that there is a circuit issue
- The Power LED is orange and the feeder or spinner speed indicator is flashing—indicates that

the feeder or spinner has encountered an obstacle and is trying to free itself

Note: Do not shut down the system at this time.

- The Power LED flashes red and the feeder or spinner speed indicator is flashing—indicates that the feeder or spinner could not free the jam
- The Power LED rapidly flashes orange and the feeder or spinner speed indicator is flashing—indicates that the motor has shut down and is cooling for 3 minutes

Note: Turning the machine off and on again does not reset the timer.

- The feeder speed indicator displays a “D”—indicates that the dump switch has been activated
- The Light LED flashes red—indicates that a rear light is burnt out or disconnected
- The Power LED flashes red and the controller beeps once—indicates that the vehicle is not supplying enough voltage to run the spreader continuously

Cleaning

Cleaning the Machine

Service Interval: Before each use or daily

Empty the cleanout tray after every use.

Important: Leaving any material in the spreader could damage the machine.

1. Remove the spinner assembly; refer to [Removing the Spinner Assembly \(page 17\)](#).
2. Disconnect the power/ground cable and main harness from the wire harness.
3. Lift up on the cleanout tray handle to clear the mount holes and slide the tray out ([Figure 28](#)).

Note: This step will require at least 2 people.

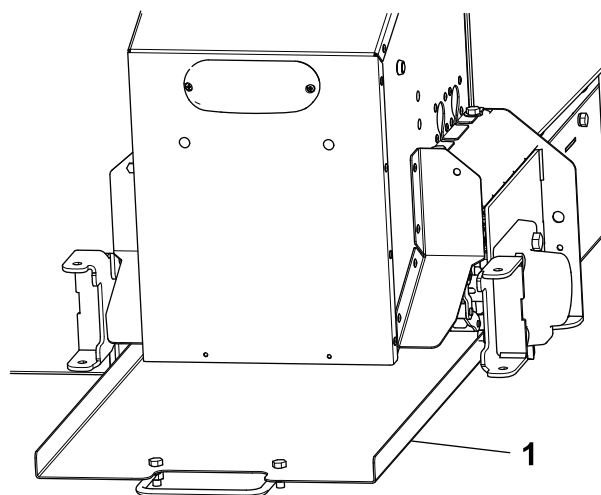

Figure 28

g248364

1. Cleanout tray

-
4. Remove any material from the tray.
 5. Insert the tray into the spreader.
 6. Connect the power/ground cable and main harness to the wire harness.

Storage

1. Unload the spreader; refer to [Unloading the Spreader \(page 17\)](#).
2. Remove the spreader from the truck using the lift/tie-down points; refer to [Loading the Spreader \(page 15\)](#).
3. Wash and rinse the entire unit.
4. Clean and grease all of the bearings.
5. Clean and grease the pintle chain (for pintle-chain models).
6. Clean all exposed connectors and apply dielectric grease to them.
7. Remove the controller from the truck and store it in a clean, dry place.

Troubleshooting

Problem	Possible Cause	Corrective Action
The controller has no power.	<ol style="list-style-type: none"> 1. The spade connector is not connected to the ignition switch power source. 2. The the ignition switch, battery, or ground connections are corroded. 3. The 2 A in-line fuse in the vehicle side harness is not functioning. 4. The controller is not plugged into the vehicle side harness. 	<ol style="list-style-type: none"> 1. Connect the spade connector to the ignition switch power source. 2. Clean the ignition switch, battery, and ground connections. 3. Replace the fuse. 4. Plug in the controller.
All of the LEDs are flashing red and the controller beeped once.	<ol style="list-style-type: none"> 1. The spreader and vehicle wire harnesses are not connected. 2. The power/ground cable is not connected to the spreader. 3. The controller is not communicating with the control module. 4. The connection between the gearbox and driveshaft is bad. 	<ol style="list-style-type: none"> 1. Connect the wire harnesses. 2. Connect the power/ground cable to the spreader. 3. Check the power/ground cable connection at the bumper and the control module. 4. Contact your Authorized Service Dealer.
The Power LED is flashing red and the controller beeped once.	<ol style="list-style-type: none"> 1. The battery or alternator is bad. 	<ol style="list-style-type: none"> 1. Charge or replace the battery or alternator.
1 of the button LEDs on my controller is flashing red.	<ol style="list-style-type: none"> 1. The button below the LED is stuck down. 2. The controller is not connected properly. 	<ol style="list-style-type: none"> 1. Unstick the button. 2. Connect the controller. Replace the controller if the connections are fine.
The Power LED is orange and the feeder or spinner speed indicator is flashing.	<ol style="list-style-type: none"> 1. There is a clog in the feeder or spinner. 	<ol style="list-style-type: none"> 1. No action needs to be taken. Do not turn off the spreader.
The Power LED is flashing red and the feeder or spinner speed indicator is flashing.	<ol style="list-style-type: none"> 1. The feeder or spinner is unable to free the clog. 	<ol style="list-style-type: none"> 1. Press the Power button to try again.
The Power LED is rapidly flashing orange and the feeder or spinner speed indicator is flashing.	<ol style="list-style-type: none"> 1. The feeder or spinner motor is resting for 3 minutes. 	<ol style="list-style-type: none"> 1. Wait 3 minutes until attempting to operate the spreader.
The Light LED is flashing red.	<ol style="list-style-type: none"> 1. 1 of the rear lights is burnt out or disconnected. 	<ol style="list-style-type: none"> 1. Check the connection, and replace the bulb if necessary.
The Vibrator LED is flashing red.	<ol style="list-style-type: none"> 1. The vibrator is disconnected or broken. 	<ol style="list-style-type: none"> 1. Check the vibrator connection, and replace the vibrator if necessary.
The Power LED is red and the feeder or spinner speed indicator is flashing.	<ol style="list-style-type: none"> 1. The feeder or spinner motor is disconnected or there is a circuit issue 	<ol style="list-style-type: none"> 1. Disconnect the motor power, then connect it again. If the problem persists, contact your Authorized Service Dealer.
The feed motor is running but the auger does not move.	<ol style="list-style-type: none"> 1. There is no connection between the gearbox and driveshaft. 	<ol style="list-style-type: none"> 1. Contact your Authorized Service Dealer.

BOSS
S N O W P L O W